

## **c.LOGiC lite-Interface**

### **C1-C20**

**Compatible with navigation systems**

**Mercedes Benz**

**Comand 2.0**

**Comand APS CD**

#### **Product features**

- full plug and play multimedia interface
- 1 AV-input with separate IR-control channel
- control of after-market devices, e.g. DVB-T tuner, DVD-player, DVD-changer, ...
- after-market rear-view camera input activation
- automatic switching to rear-view camera input (only from c.LOGiC-mode)
- rear-view camera power (+12V max. 1A)
- power on remote out trigger signal (+12V max. 1A) to switch on connected devices
- video-in-motion

## Contents

### 1. Prior to Installation

- 1.1. Delivery contents
- 1.2. Check compatibility of vehicle and accessories

### 2. Connection schema

### 3. Installation

- 3.1. Connections to the Comand
- 3.2. Interconnecting Interface-box and harnesses
- 3.3. Connecting peripheral devices
  - 3.3.1. AV-source
  - 3.3.2. Installing AV-source's IR-sensor additionally
  - 3.3.3. After-market rear-view camera

### 4. Operation

- 4.1. Activation of the video-in-motion function
- 4.2. Selecting the c.LOGiC as current AV-source
- 4.3. Assigning device control
- 4.4. Button assignment table
- 4.5. Picture settings
- 4.6. Audio settings

### 5. Specifications

### 6. Connections (Interface-box)

### 7. Technical support

### Appendix A – Device control table

## Legal Information

By law, watching moving pictures while driving is prohibited, the driver must not be distracted. We do not accept any liability for material damage or personal injury resulting, directly or indirectly, from installation or operation of this product. This product should only be used while standing or to display fixed menus or rear-view-camera video when the vehicle is moving, for example the MP3 menu for DVD upgrades.

Changes/updates of the vehicle's software can cause malfunctions of the interface. We offer free software-updates for our interfaces for one year after purchase. To receive a free update, the interface must be sent in at own cost. Labor cost for and other expenses involved with the software-updates will not be refunded.

## 1. Prior to installation

Read the manual prior to installation. Technical knowledge is necessary for installation. The place of installation must be free of moisture and away from heat sources.

### 1.1. Delivery contents

*Take down the SW-version and HW-version of the interface boxes, and store this manual for support purposes.*



If remote function for the connected devices shall be used, additionally an IR-remote cable and Y-adapter are needed, see chapter [AV-source](#) .

## 1.2. Check compatibility of vehicle and accessories

### Requirements

*Vehicle* Mercedes Benz C-Class (W203) til 04/2004, CL-Class (C215) from 09/2002 til 09/2003, CLK-Class (C208 W208) all years, CLK-Class (C209 W209) til 05/2004 , E-Class (W210) all years , G-Modell (W463) til 03/2007, ML-Class (W163) all years, S-Class (W220) from 09/2002 til 09/2003, SL-Class (R230) til 06/2004

*Navigation* Comand 2.0, Comand APS CD

### Limitations

*Factory-TV-tuner* Must NOT be installed.

*After-market rear-view cam* Automatic switching to camera only works from c.LOGiC mode

## 2. Connection schema

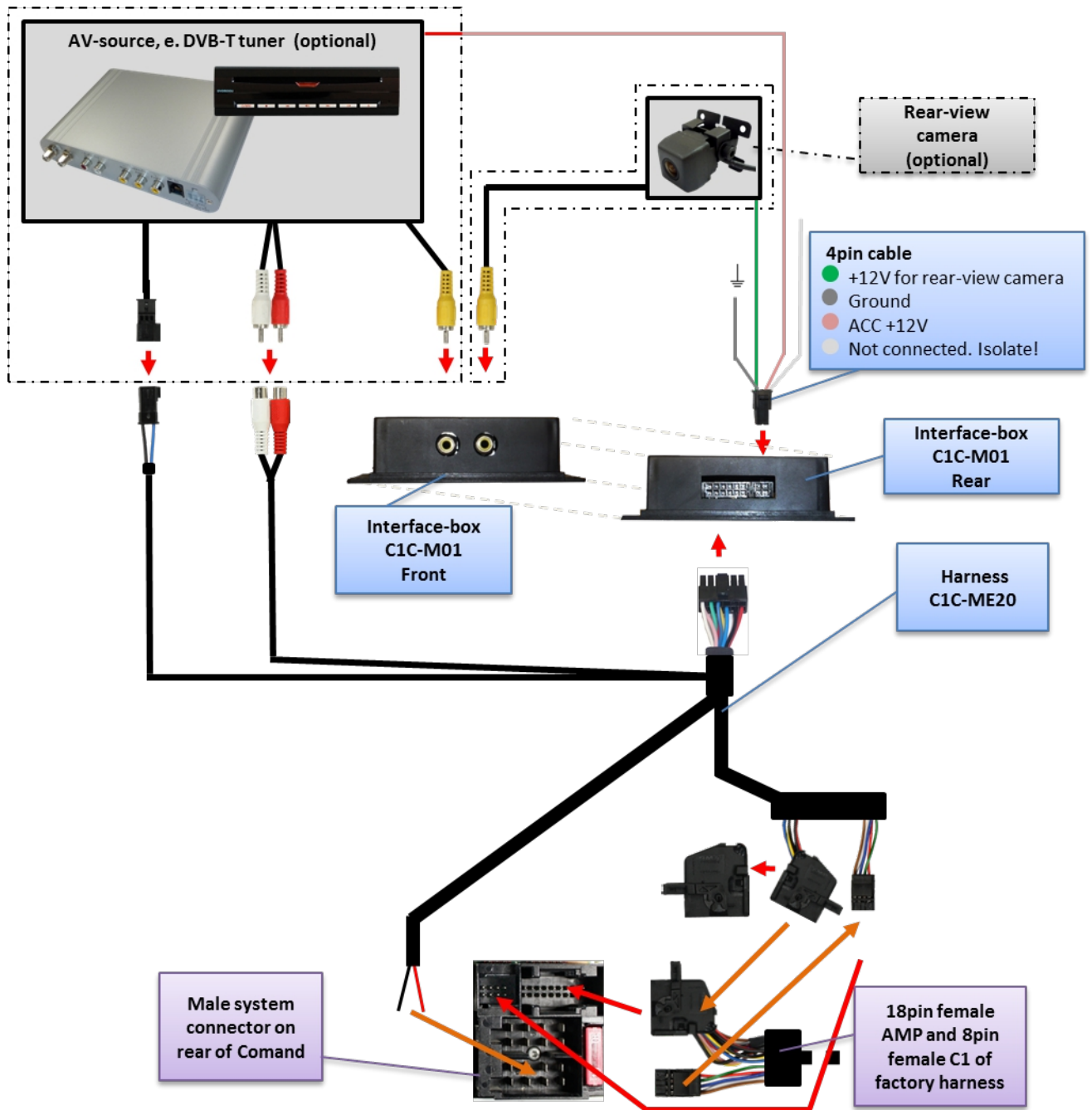

## 3. Installation

**Switch off ignition and disconnect the vehicle's battery! If according to factory rules disconnecting the battery has to be avoided, it is usually sufficient to put the vehicle in sleep-mode. In case the sleep-mode does not show success, disconnect the battery with a resistor lead.**

## 3.1. Connections to the Comand

Place of installation is behind the Comand. Remove the head-unit from the dash-board.

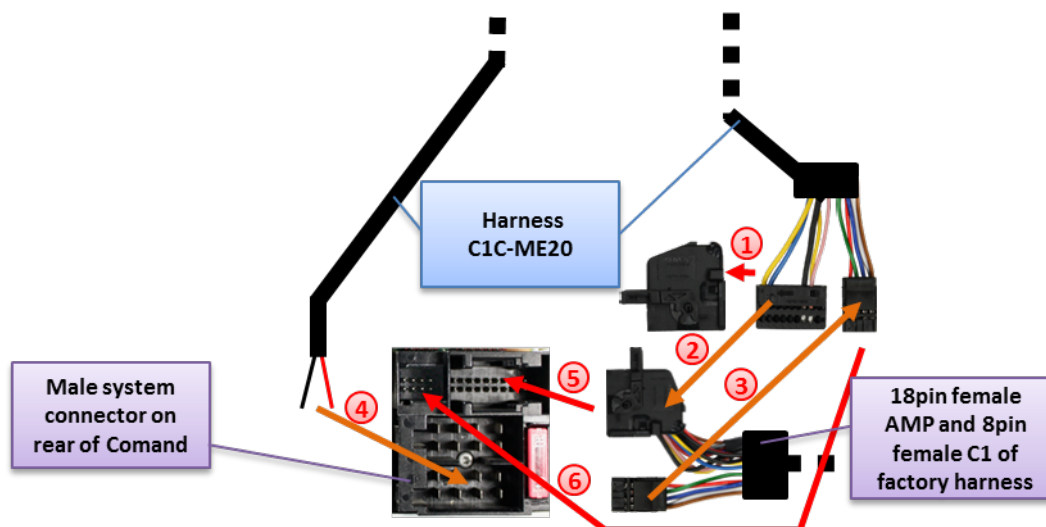

- ① Remove shell from female 18pin AMP connector of C1C-ME20.
- ② Transfer pins 2 (red), 11 (white), 3 and 12 (black) from female 18pin AMP connector of C1C-ME20 to corresponding slots of female 18pin AMP connector of factory harness. If occupied remove and isolate factory wires (take notes before removing).  
Transfer pins 17 (blue) and 18 (yellow) from female 18pin AMP connector of C1C-ME20 to corresponding slots of female 18pin AMP connector of factory harness. If occupied connect additionally to the factory wires.
- ③ If existing transfer pins 5 and 6 from female 8pin C1 connector of factory harness to corresponding slots of female 8pin C1 connector of C1C-ME20. If existing, other pins remain in the factory connector.

- ④ Connect loose red wire of C1C-ME20 to pin 4 of chamber A (+12V battery power). Connect loose black wire of C1C-ME20 to pin 8 of chamber A (ground).
- ⑤ Plug female 18pin AMP connector of vehicle harness into C2 slot of Comand's male system connector.
- ⑥ Plug female 8pin C1 connector of harness C1C-ME20 into C1 slot of Comand's male system connector.

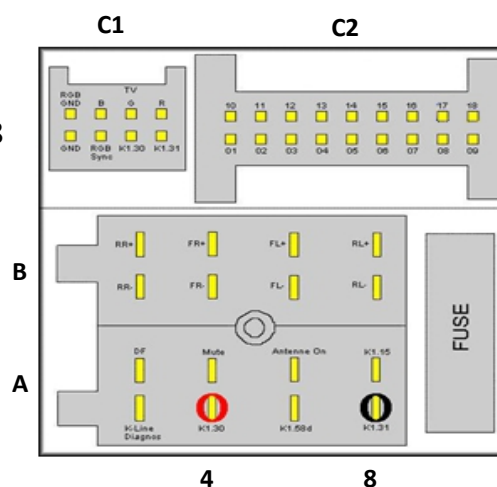

## 3.2. Interconnecting Interface-box and harnesses

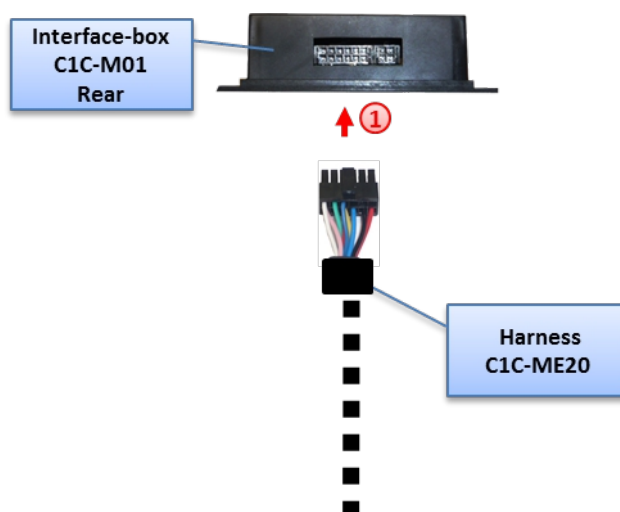

- 1 Plug harness C1C-ME20 into 12pin Molex of Interface-box C1C-M01.

## 3.3. Connecting peripheral devices

It is possible to connect one after-market AV-source and an after-market rear-view camera to the c.LOGiC Interface.

**Before final installation of the peripheral devices, we recommend to test-run the c.LOGiC functions to detect incompatibility of vehicle, navigation, factory accessories or peripheral devices as soon as possible.**

### 3.3.1. AV-source

The c.LOGiC interface has the possibility to connect and remotely control by navigation buttons one pre-programmed device. The device list in the device control table (Appendix A) shows the pre-programmed remote channels and the related IR-remote cables STA-xxx which must be ordered separately for the control of the device.

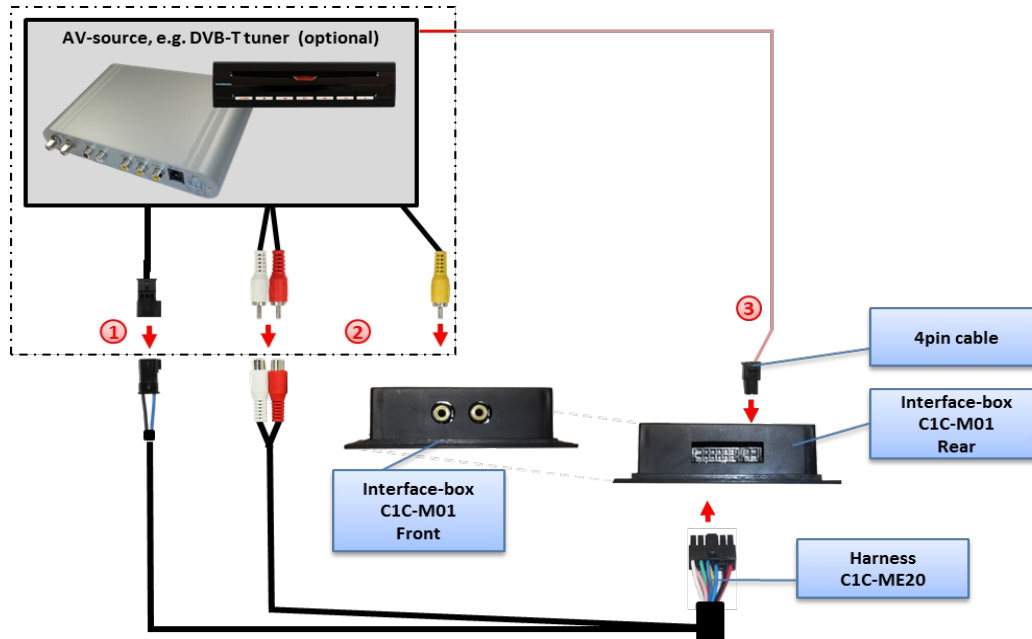

- ① Using the respective STA-xxx IR-control cable, interconnect the blue female 3pin AMP connector of harness C1C-ME20 and the IR-port of the AV-source.
- ② Using an RCA-cable, interconnect the female RCA-port Video In of the Interface-box C1C-M01 with the AV-output of the AV-source.
- ③ The pink ACC-output wire (+12V max. 1A) of the 4pin cable can be connected to the ACC-input wires of the connected device to switch it on. It carries +12V when the head-unit is running.

### 3.3.2. Installing AV-source's IR-sensor additionally

Additionally to the control via OEM navigation, it is possible to install the original IR-sensor of a connected device. By using the respective Y-adapter (e.g. STA-Y35MM or STA-RJ12) for the IR-Port of the connected device, the controls of navigation AND device's IR-sensor can be connected and used simultaneously. Installation of the IR-sensor is recommended as the controls via navigation are limited, and not all functions may be covered.

### 3.3.3. After-market rear-view camera

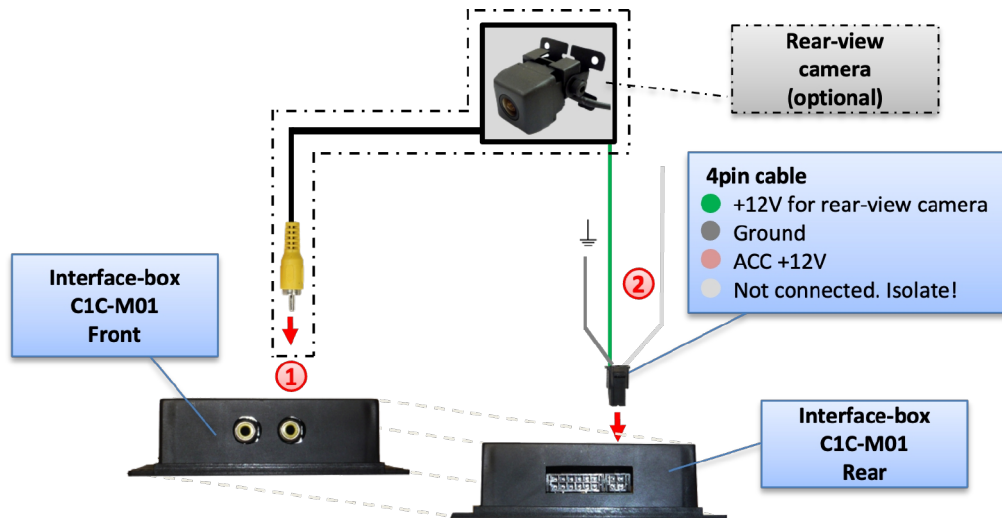

- ① Connect the video RCA of the after-market rear-view camera to female RCA connector R-CAM IN of Interface-box C1C-M01.
- ② Connect the green wire of the 4pin cable to the camera power supply (+12V max. 1A) of the after-market rear-view camera and the grey wire to ground of the vehicle. The green wire is high (+12V max. 1A) when reverse gear is engaged. The white wire is not connected and has to be isolated. In some cases it is possible that the automatic switching does not work. In this case connect the white wire to the reverse gear light (+12V).

**Note:** Automatic switching to camera only works from c.LOGiC mode.

## 4. Operation

### 4.1. Activation of the video-in-motion function

The video of the c.LOGiC is displayed also in motion.

**Note:** On vehicles with previously installed factory TV-tuner an extra video-in-motion interface might be necessary. It is not possible to determine this prior to testing.

### 4.2. Selecting the c.LOGiC as current AV-source

Push **TV** button of Comand to choose the c.LOGiC as current AV-source.

### 4.3. Assigning device control

After selecting the c.LOGiC as current AV source, longpress the number “1”-button or shortpress the “RET”-button. The display in the instruments will show “TV 1” and “RC01”. Turn right knob until the device-related IR-code as described in device control table (appendix A) is reached. Push right knob to confirm the assignment.



If the vehicle has no MFD display in the instrument panel, you must count the notches when turning the knob (to the right +1, to the left -1). At the same time, remember that the starting point is channel RC01 (the first notch to the right is then already RC02).

**Note:** The IR-control channel is preset to RC-Code 41 compatible DVB-T tuners.

### 4.4. Button assignment table

The button assignment table shows which functions of the connected devices can be executed by Comand buttons. Once the AV-input is activated, the Comand button in the left column will execute the function described in the corresponding device column. The function description equals the remote control buttons of the optional c.LOGiC remote control or the additional device. On the additional device the writing may vary (e.g. AV instead of Source).



Button assignment table c.LOGiC Comand 2.0/APS CD/APS 220						
COMAND button	DVB-T	USB-LiNK	DVD-player	DVD-changer	iPod®-control	Analog-tuner
1	SCAN	POWER	PLAY	PLAY	PLAY/PAUSE	SCAN
2	↑	↑	↑	↑	↑	VOL +
3	EPG	EXIT	STOP	STOP	POWER	FM
4	←	←	←	←	←	CH -
4 long	DISPLAY	VOL-	DISPLAY	DISPLAY		DISPLAY
5	OK	OK / PLAY	OK	OK	ENTER	MODE
6	→	→	→	→	→	CH +
6 long	AUDIO	VOL+	AUDIO	AUDIO	MUTE	FM
7	EXIT	MEDIA	PBC	DISC	SHUFFLE	MUTE
7 long	LANG	OSD	SUB	SUB		MUTE
8	↓	↓	↓	↓	↓	VOL -
9	MENU	SETUP	SETUP	SETUP	LIGHT	ADJUST
11	AV	MEDIA	AV	AV	EJECT	DISPLAY
11 long	POWER	POWER	POWER	POWER	POWER	POWER
14	↓	↓	TRACK +	TRACK +	TRACK +	CH +
15	↑	↑	TRACK -	TRACK -	TRACK -	CH -
16	OK	OK / PLAY	OK	OK	ENTER	MODE
17	CH -	TRACK -	TRACK -	TRACK -	TRACK -	CH -
18	CH +	TRACK +	TRACK +	TRACK +	TRACK +	CH +

Additionally to the head-unit buttons, the steering-wheel buttons UP and DOWN can be used for remote functions. DOWN-button has the same function as **17** on the head-unit and UP-button has the same function as **18** on the head-unit.

#### 4.5. Picture settings

By pressing the button **10**, it is possible to switch between 4:3 and 16:9 picture format (Only possible on Comand APS CD/220).

To enter the picture settings menu longpress button **13**.

The picture settings menu always starts with the brightness settings. The respective current picture value is displayed on the instrument panel.

Press the right knob to change from brightness to colour and contrast (after contrast, the interface starts again with brightness).

Turn the right knob to change the current picture value. To quit the settings menu press button **13**.



## 4.6. Audio settings

To enter the Comand's audio settings menu press button **12**.

## 5. Specifications

Operation voltage	10.5 – 14.8V DC
Stand-by power drain	<1mA
Operation power drain	240mA
Power consumption	3W
Temperature range	-30°C to +80°C
Weight	95g
Measurements (box only) B x H x T	106 x 30 x 71 mm

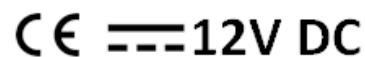
CE  12V DC

## 6. Connections (Interface-box)

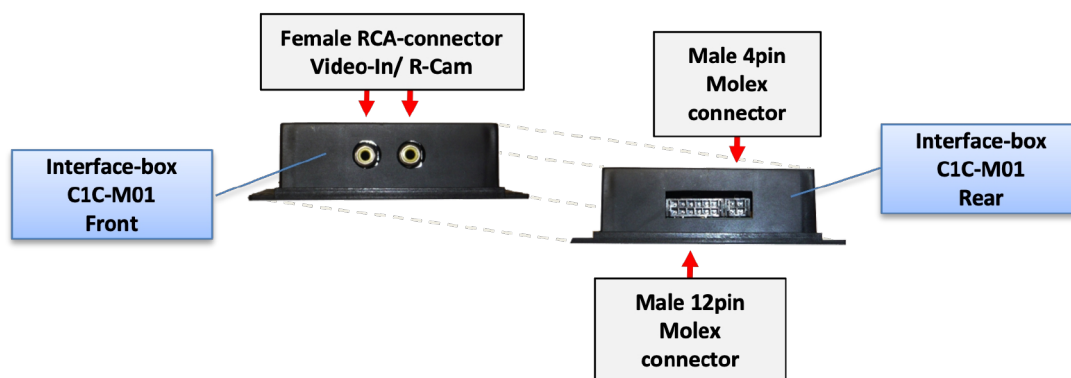

## 7. Technical Support

**Caraudio-Systems Vertriebs GmbH**  
*manufacturer/distribution*  
In den Fuchslöchern 3  
D-67240 Bobenheim-Roxheim

email [support@caraudio-systems.de](mailto:support@caraudio-systems.de)

**Legal disclaimer:** Mentioned company and trademarks, as well as product names/codes are registered trademarks ® of their corresponding legal owners.