

FanControl-U2

Connection of the module in Mercedes-Benz vehicles

Installing the module in Mercedes-Benz: 221 (S-class) and 216 (CL-class) chassis

<p>Group 2, subgroup 1 Vehicle CAN bus:</p> <ul style="list-style-type: none"> • CAN-L – brown • CAN-H – brown with a red stripe. 	<p>Standard control button:</p> <ul style="list-style-type: none"> • Central lock locking button located on driver's door.
---	--

Control of an aftermarket heater

CAN1 and CAN3 of the module are connected in series to the vehicle's CAN-bus going to the KLA unit. CAN3 is connected in the direction of the KLA unit and CAN1 to the opposite side of the vehicle's CAN-bus. In order to keep the factory wiring of the vehicle intact, it is recommended to disassemble the appropriate connector and then reassemble it using the special plastic connectors supplied with the module (figures 5-9).

The CAN-bus may be connected to:

1. To the CAN-bus at the KLA unit. The unit is located behind the glove compartment (see figure 1).
2. To the CAN-bus at the CAN distributor located on the plastic cover to the left and above the driver's footrest (see figure 2).

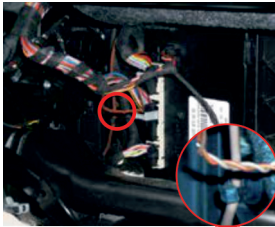

Figure 1

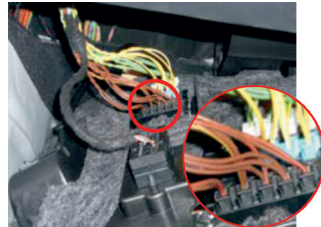

Figure 2

One of the twisted pairs from the CAN distributor leads directly to the KLA unit.

How to find the appropriate twisted pair:

With the ignition on and with marker lights OFF disconnect one by one the connectors of the CAN distributor.

If an appropriate connector is disconnected, there will be no control over the climate system (fan speed, air temperature and etc.), the buttons located on the center stack which is situated between the front seats will not illuminate when the marker lights are OFF, in addition there should't be error messages in the instrument cluster. Refer to the diagram 1 for details.

Installing the module in Mercedes-Benz: 204 (C-class, GLK-class), 207 (E-class) and 212 (E-class)

<p>Group 2, subgroup 1 Vehicle CAN bus:</p> <ul style="list-style-type: none"> • CAN-L – brown • CAN-H – brown with a red stripe. 	<p>Standard control button:</p> <ul style="list-style-type: none"> • Central lock locking button located on driver's door.
---	--

Control of an aftermarket heater

In the MB 204, 207, 212 the instrument cluster may periodically illuminate while the FanControl module is running. The module is connected to the vehicle's CAN-bus in series which is located behind the KLA unit in the 16-pin connector (see figures 3,4):

Pin №1 brown/red (CAN-H);

Pin №2 brown (CAN-L).

CAN3 of the module is connected in the direction of the KLA unit and CAN1 in the opposite direction. In order to keep the factory wiring of the vehicle intact, it is recommended to disassemble the appropriate connector of the KLA unit and then reassemble it using the special plastic connectors supplied with the module (figures 5-9).

Figures 5-9 represent an example of such connection at the KLA unit connector in Mercedes-Benz vehicles (204, 207 and 212 chassis).

For detailed description of connection see Diagram 1.

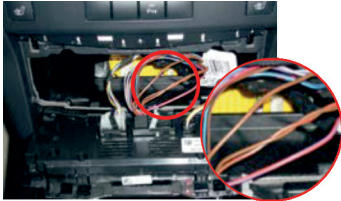

Figure 3

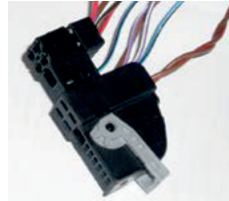

Figure 4

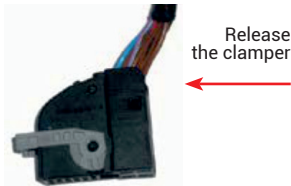

Figure 5

Release the clammer



Figure 6

Disassemble the connector

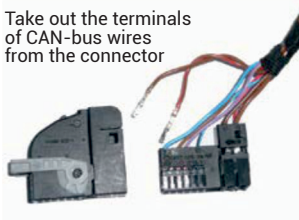

Figure 7

Take out the terminals of CAN-bus wires from the connector

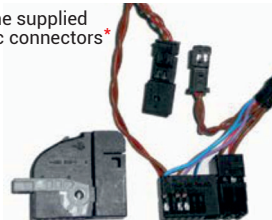

Figure 8

Use the supplied plastic connectors*

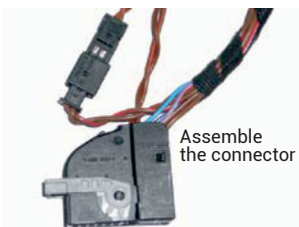

Figure 9

Assemble the connector

* Insert the extracted wires into the 2-pin enclosure of the connector included in the kit as follows: a brown/red one into pin #1 and a brown one into pin #2. Connect the resulting 2-pin connector with a mating connector (with inserted module CAN 1 twisted pair). Make sure that the brown wire is connected with the brown one, and the brown/red wire with the brown/red one. Then insert the module's twisted pair CAN-3 with "female" terminals at wires' ends into pins #1 (brown/red) and #2 (brown) of the factory connector.

Installing the module in Mercedes-Benz: 166 (ML-class), 463 (G-class, 2013-2018), 218 (CLS-class), 156 (GLA-class), 176 (A-class), 292 (GLE-class)

Group 2, subgroup 1
Vehicle CAN bus:

- CAN-L – brown
- CAN-H – brown with a red stripe.

Standard control button:

- Central lock locking button located on driver's door.

Control of an aftermarket heater

The instrument cluster of these cars may periodically illuminate while the FanControl module is running. The module is connected to the vehicle's CAN-bus in series which is located behind the KLA unit (figures 10-11).

- brown/red (CAN-H);
- brown (CAN-L).

CAN3 of the module is connected in the direction of the KLA unit and CAN1 in the opposite direction. In order to keep the factory wiring of the vehicle intact, it is recommended to disassemble the appropriate connector of the KLA unit (at the distributor or the KLA unit) and then reassemble it using the special plastic connectors supplied with the module (figures 12-15).

Refer to the diagram 1 for details.

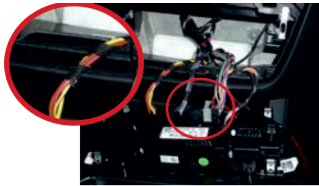
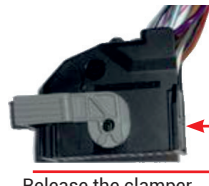
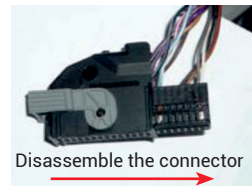

Figure 10



Release the clasper

Figure 11



Disassemble the connector

Figure 12

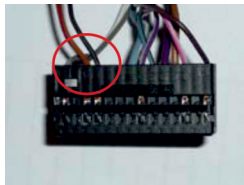
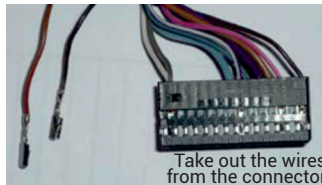
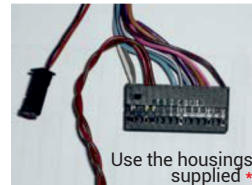

Figure 13



Take out the wires from the connector

Figure 14



Use the housings supplied *

Figure 15

* Insert the extracted wires into the 2-pin enclosure of the connector included in the kit as follows: a brown/red one into pin #1 and a dark brown one into pin #2. Connect the resulting 2-pin connector with a mating connector (with inserted module CAN 1 twisted pair). Make sure that the brown wire is connected with the dark brown one, and the brown/red wire with the brown/red one.

Then insert the module's twisted pair CAN-3 with "female" terminals at wires' ends into pins #3 (brown/red) and #4 (brown) of the factory connector.



By default the climatic system is turned on in the "blow-off" mode designed by the vehicle manufacturer. The module can be programmed so the climatic system would activate in the mode that had been used last time before the ignition was turned off.

Adjusting the last used mode:

1. Within 10 sec after turning the ignition off press the programming button 14 times.
2. The LED will flash 1 time to indicate the status of the option №14 .
3. Press the programming button 1 time.
4. The LED will flash 2 times to indicate that the status of the option has changed.
5. Wait 15 seconds.
6. 4 flashes of the LED mean that the last used mode has been saved, 1 long flash indicates an error.

Control of a factory parking heater (only for 166, 463, 156)

The module allows to switch on the factory heater for engine and interior warm-up from additional devices (GSM pager, auxiliary car alarm etc.) through the external input, by the standard vehicle button (central lock locking button located on driver's door) or by the factory remote control.

The module is connected to CAN bus at any convenient place, for instance, behind the KLA unit (see Figure 10). Module CAN 1 paired wire is used for connection.

For detailed description of connection see Diagram 2.

Installing the module in Mercedes-Benz: 217, 222 (S-class 2013-2017)

<p>Group 9, subgroup 3 Vehicle CAN bus:</p> <ul style="list-style-type: none"> • CAN-L – brown • CAN-H – brown with a red stripe. 	<p>Standard control button:</p> <ul style="list-style-type: none"> • Central lock locking button located on driver's door.
--	--

Control of an aftermarket heater

Connection is performed right after KLA unit that is located behind the glove box (see Figures 16-19).



Figure 16

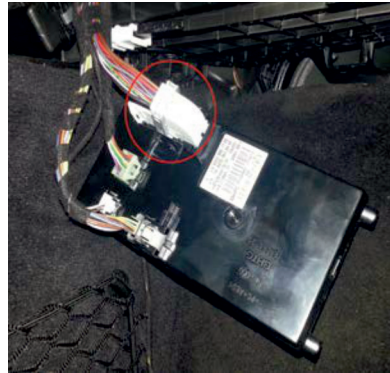

Figure 17

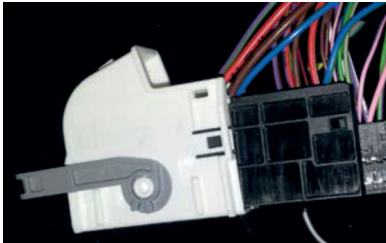

Figure 18



Figure 19

The module is connected to the vehicle interior CAN bus coming to the KLA unit by cutting into CAN bus.

Module CAN 1 and CAN 3 paired wires are designed for connection of the module to CAN bus: CAN 3 is connected to the bus from the KLA unit side and CAN 1 – from the vehicle side.

When connecting the module to the CAN bus it is recommended to disassemble the relevant vehicle's connector (at the distributor or KLA unit) and then assemble it again using connector enclosures included in the kit. Such connection method does not violate vehicle's factory electric wiring.

Climatic system can be set in two modes:

- Mode that was set before turning the ignition off. For detailed description of connection see Diagram 1.
- Special mode, that can be set during installation (only for Mercedes Benz 222).

Following parameters can be adjusted: fan speed, temperature, flow direction, MAX or AUTO mode can be set.

Climatic system settings

To set up climatic system:

1. Turn on the ignition
2. Set climatic system in preferred mode
3. Press and hold the central locking «unlock» button located on the driver's door for 2 sec.
4. If everything was set correctly, LED will flash 4 times.

! After turning on the module climatic system will set all parameters (fan speed, flow directions, temperature) in sequence. And after ignition is on all parameters will return to the ones that were set before turning ignition off.

Control of an original (factory) heater (only for MB 222 (S-class))

The module allows to switch on the factory heater for engine and interior warm-up from additional devices (GSM pager, auxiliary car alarm etc.) through the external input, by the standard vehicle button (central lock locking button located on driver's door) or by the factory remote control.

The module is connected to CAN bus at any convenient place, for instance, behind the KLA unit (see Figure 17). Module CAN 1 paired wire is used for connection.

LIN bus connection is also required. Connection is performed near KLA unit to white connector (see Figure 17).

Module is connected by cutting into LIN bus before KLA unit (pin 14) (see Figure 20). For detailed description of connection see Diagram 3.

LIN 1 (gray/green) connects to the bus from the climate unit's side.

LIN 2 (gray/blue) connects to the bus from the vehicle's side.

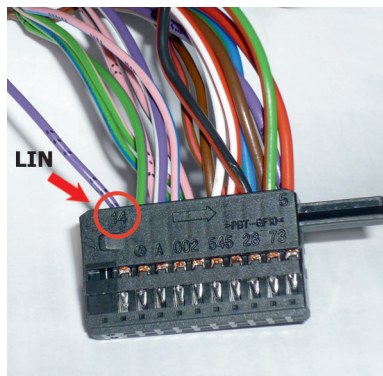

Figure 20

! By default the climatic system turns on in "blow off" mode designed by manufacturer. Module allows switching on climatic system and stock aftermarket heater at the same time.

Climatic system can be set in two modes:

1. Mode that was set before turning the ignition off
2. Special mode, that can be set during installation

Installing the module in Mercedes-Benz: 222 (S-class, 2017--), 205 (C-class), 253 (GLC), 213 (E-class)

<p>Group 9, subgroup 3. For MB 213 and 222 - group 9, subgroup 5. Vehicle CAN bus:</p> <ul style="list-style-type: none"> • CAN-L – brown • CAN-H – brown with a red stripe. 	<p>Standard control button:</p> <ul style="list-style-type: none"> • Central lock locking button located on driver's door
---	---

Control of an aftermarket heater

The connection is performed at the KLA unit located behind the glove compartment (figures 21 -24).



Figure 21

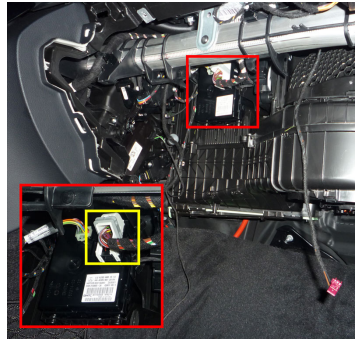

Figure 22

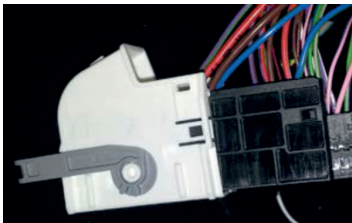

Figure 23



Figure 24

The module is connected in series to the CAN-bus going to the KLA unit. CAN1 and CAN3 of the module are connected as follows: CAN3 is connected in the direction of the KLA unit and CAN1 is connected in the direction of the vehicle. When connecting the module to the CAN-bus it is recommended to disassemble the vehicle's connector (of the KLA unit) and then assemble it back using the special plastic connectors supplied with the module. This connection method doesn't harm the vehicle's wiring. Refer to the diagram 1 for connection details.

The climate control system is activated simultaneously with an aftermarket engine heater.

The climate system can operate in either one of the two modes:

- In a mode that had been used before the ignition was turned off.
- In a mode which can be specially adjusted when installing the module (only for MB 205). The adjustable parameters are: fan speed, temperature, air flow distribution.

To adjust a preferable operating mode of the climate system, follow the procedure described below.

! If the vehicle is equipped with factory PTC air heaters, they must be disabled while the FanControl module is running.

Adjusting the climatic system

1. Switch the vehicle's ignition ON.
2. Adjust preferable climatic system parameters to be activated by FanControl module.
3. Press and hold for no less than 2 seconds the central locking «unlock» button located on the driver's door.
4. If the settings of the preferable mode are successfully saved, the LED will flash 4 times.

! When the FanControl is activated the climate system gradually switches on the pre-adjusted parameters (fan speed, temperature, air distribution). When the vehicle's ignition is turned on, the climate system restores the settings that had been used before the ignition was turned off.

Control of a factory parking heater (only for MB 253 (GLC), MB 213 (E), 222 (S 2017--))

The module allows to switch on the factory parking heater to warm up the vehicle's engine and interior. The module is connected to the vehicle CAN-bus in any convenient place, e.g. at the KLA unit (Figure 22). Use CAN1 of the module to connect it to the vehicle CAN-bus. It is also required to connect the LIN-bus. The connection is performed at the KLA unit in the white connector (figure 22). The LIN of the module is connected to the vehicle's LIN in series (pin №14, figure 25). Refer to the diagram 3 for connection details. LIN1 of the module (grey/green wire) is connected in the direction of the KLA unit. LIN2 of the module to the opposite direction (to the vehicle).

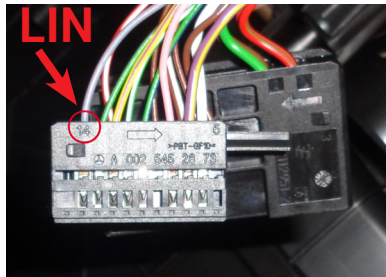

Figure 25

! The climate system is activated simultaneously with the factory parking heater. The climate system is turned on in the blowing mode designed by the vehicle manufacturer and with the temperature settings that had been used before the ignition was turned off.

Installing the module in Mercedes Benz: 447 (V-class)

Group 9, subgroup 2

Vehicle CAN bus:

- CAN-L – brown
- CAN-H – brown with a red stripe.

Standard control button:

- Central lock locking button located on driver's door

Control of an aftermarket heater

Control of an aftermarket heater

The module is connected at the KLA unit which is located behind the glovebox (figures 26-29).



Figure 26



Figure 27

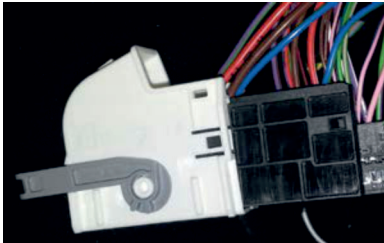

Figure 28

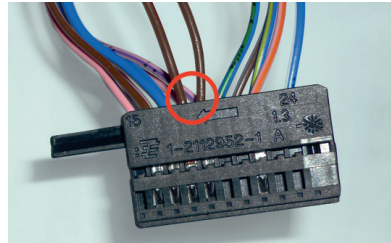

Figure 29

The module is connected to the vehicle's CAN-bus going to the KLA unit in series: CAN3 is connected in the direction of the KLA unit and CAN1 in the opposite direction. It is recommended to disassemble the corresponding connector of the KLA unit and then re assemble it using the plastic connectors supplied with the unit, this will help to avoid damaging the factory wiring. Refer to the diagram 1 for details.

- ! The climate system will activate in the mode that had been used before the vehicle's ignition was turned on.
- ! If the vehicle is equipped with factory PTC air heaters, they must be disabled while the FanControl module is running.

Control of a factory parking heater

The module activates the factory parking heater to warm up the engine and interior. The module may be controlled with external devices (GSM pager, auxiliary car alarm and etc.), through the external control inputs, with the original vehicle's button (central locking «lock» button located on the driver's door), with the «lock» button located on the factory remote key.

The module is connected to CAN bus at any convenient place, for instance, behind the KLA unit (see Figure 27). Module CAN 1 paired wire is used for connection.

LIN bus connection is also required. Connection is performed near KLA unit to white connector (see Figure 27).

Module is connected by cutting into LIN bus before KLA unit (pin 14) (see Figure 30). For detailed description of connection see Diagram 8.

LIN 1 (gray/green) connects to the bus from the climate unit's side.

LIN 2 (gray/blue) connects to the bus from the vehicle's side.

 The climate system is activated in the standard blowing mode designed by the vehicle manufacturer.

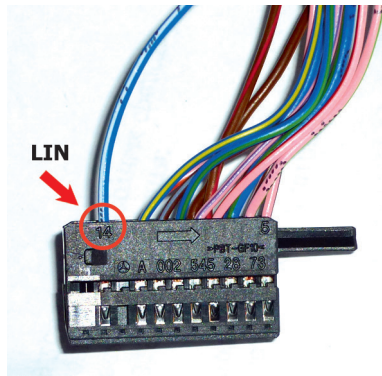

Figure 30

Installing the module in Mercedes Benz: 447 (Vito)

Group 9, subgroup 2 with aftermarket heater
Group 9, subgroup 4 with factory heater
Vehicle

CAN bus:

- CAN-L – brown
- CAN-H – brown with a red stripe

Standard control button:

- Central lock locking button located on driver's door.

Control of an aftermarket heater

The connection to the vehicle's CAN-bus is performed at the KLA unit (figures 31-33) by connecting CAN1 and CAN3 of the module in series.



Figure 31

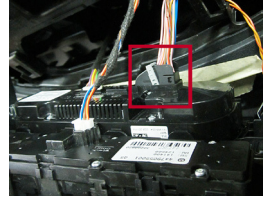

Figure 32

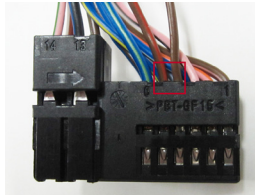

Figure 33

CAN 3 is connected in the direction of the KLA unit and CAN1 in the opposite direction. In order to keep the factory wiring of the vehicle intact, it is recommended to disassemble the appropriate connector of the KLA unit and then reassemble it using the connectors supplied with the module (figures 35-36). Refer to the diagram 1 for details.

! The climatic system will activate in the mode that had been used before the ignition was turned off.

Control of a factory parking heater

The module switches on the factory parking heater to warm up the engine and interior.

The CAN1 of the module is connected to the vehicle's CAN-bus in parallel at any convenient place, for example, behind the KLA unit (see figure 32). It is also required to connect the module to the vehicle's LIN-bus in series directly at the KLA unit (blue/white wire, see figure 34). Refer to the diagram 8 for details.

LIN1 (gray/green) is connected in the direction of the vehicle's wire harness.

LIN2 (gray/blue) is connected in the direction of the climate control panel.

! By default the climatic system is activated in the standard blowing mode designed by the vehicle manufacturer.

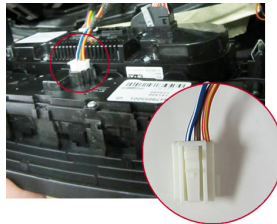

Figure 34

Installing the module in Mercedes Benz: 164 (ML, GL), 169, 203, 211, 219, 251, 463, 639 (2003-2010)

Group 12, subgroup 1 Vehicle CAN bus: <ul style="list-style-type: none"> • CAN-L – brown • CAN-H – brown with a red stripe. 	Standard control button: <ul style="list-style-type: none"> • Central lock locking button located on driver's door.
--	---

Control of an aftermarket heater

CAN1 of the module is connected to the vehicle's CAN-bus in parallel at any convenient place. Refer to the diagram 4 for details.

! By default the climatic system is activated in a standard blowing mode designed by the vehicle manufacturer.

Installing the module in Mercedes Benz: 639 (2010-2014)

Group 13, subgroup 3 Vehicle CAN bus: <ul style="list-style-type: none"> • CAN-L – brown • CAN-H – brown with a red stripe. 	Standard control button: <ul style="list-style-type: none"> • Steering wheel button "Down".
--	---

Control of an aftermarket heater

Connection is performed near KLA unit (Figures 35, 36).

- Brown-red (CAN-H)
- Brown (CAN-L).

Module has to be cut into CAN bus going into KLA unit. CAN 1 and CAN 2 pairs are used to connect module to the CAN bus: CAN 2 has to be connected from the side of KLA unit and CAN 1 from the vehicle's side. It is recommended to disassemble KLA connector, and then assemble it (use included pin covers).

This way factory wiring will not be altered. (Figure 35)

For detailed description of connection see Diagram 5.

! Climate control system will turn on in the last mode.



Figure 35

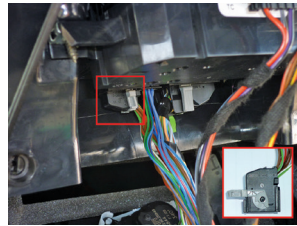

Figure 36

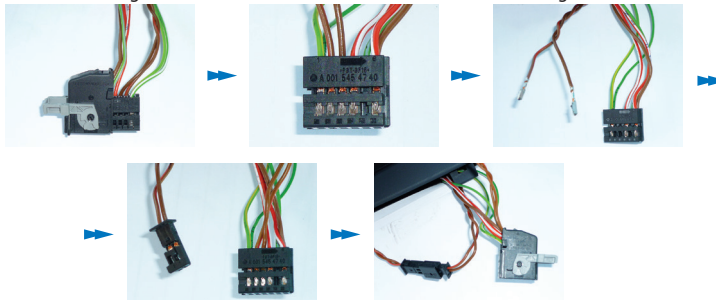

Figure 37

Control of a factory parking heater

Connection is performed near KLA unit (Figures 35 and 36).

- Brown-red (CAN-H)
- Brown (CAN-L).

Module has to be cut into CAN bus going into KLA unit. CAN 1 and CAN 2 pairs are used to connect module to the CAN bus: CAN 2 has to be connected from the side of KLA unit and CAN 1 from the vehicle's side.

Connection can be made in the power distribution unit behind the glovebox (Figures 38 and 39). One of the pairs in the distributor is connected to the heater. If it did not turn on, that is the correct pair.

For detailed description of connection see Diagram 6.

It is recommended to disassemble KLA connector, and then assemble it (use included pin covers). This way factory wiring will not be altered. (Figure 38)

! Climate control system will turn on in the last mode.



Figure 38

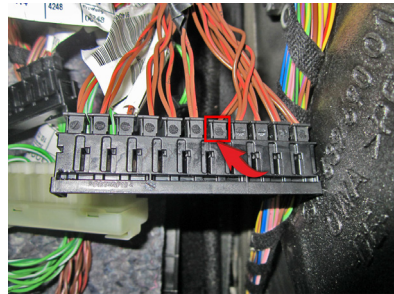

Figure 39

Installing the module in Mercedes Benz: 906

<p>Group 13, subgroup 3 Vehicle CAN bus:</p> <ul style="list-style-type: none"> • CAN-L – brown • CAN-H – brown with red stripe. 	<p>Standard control button:</p> <ul style="list-style-type: none"> • Steering wheel button "Down".
---	--

Control of an aftermarket heater

Connection is performed near KLA unit (Figure 40).

- Brown-red (CAN-H)
- Brown (CAN-L)

Module has to be cut into CAN bus going into KLA unit. CAN 1 and CAN 2 pairs are used to connect module to the CAN bus: CAN 2 has to be connected from the side of KLA unit and CAN 1 from the vehicle's side. It is recommended to disassemble KLA connector, and then assemble it (use included pin covers). This way factory wiring will not be altered.

For detailed description of connection see Diagram 5.

! Climate control system will turn on in the last mode.



Figure 40

Control of an original (factory) heater

Connection is performed near KLA unit (Figure 40).

- Brown-red (CAN-H)
- Brown (CAN-L)

Module has to be cut into CAN bus going into KLA unit. CAN 1 and CAN 2 pairs are used to connect module to the CAN bus: CAN 2 has to be connected from the side of KLA unit and CAN 1 from the vehicle's side. Connection can be made in the power distribution unit behind the glovebox (Figure 41).

Connection is made by using twisted pair X30/24.6.

For detailed description of connection see Diagram 6.

It is recommended to disassemble corresponding connector, and then assemble it (use included pin covers). This way factory wiring will not be altered.



The climatic system will activate in the last mode that had been used before the ignition was turned off.

If vehicle is equipped with mechanical temperature and airflow controls, connect green/black wire (pin N15) of the unit to the black/red wire of the climate system through a relay (pin N5) (Figure 42). For detailed description of connection see Diagram 7.

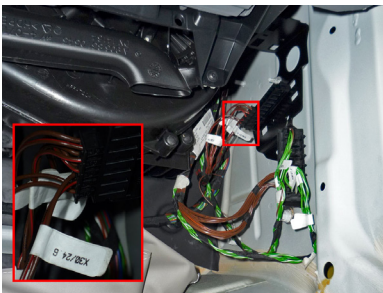

Figure 41

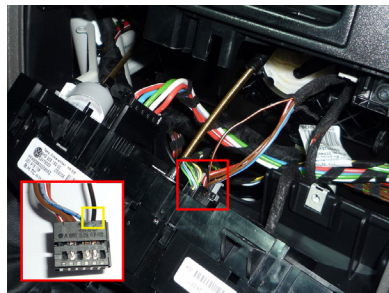

Figure 42

Installing the module in Mercedes Benz: 463 (G-class, 2018--)

Group 9, subgroup 5

Vehicle's CAN-bus:

- CAN-L – brown
- CAN-H – brown with red stripe.

Standard control button:

- Central locking «lock» button located on driver's door

Control of an aftermarket engine heater

The connection is performed right beside the KLA unit. The KLA unit is located behind the glove compartment (figures 43-45).



Figure 43

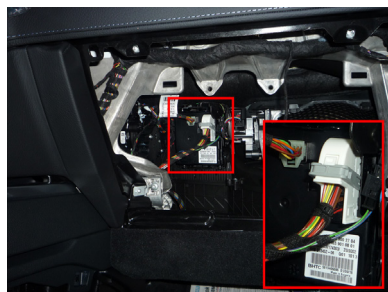

Figure 44

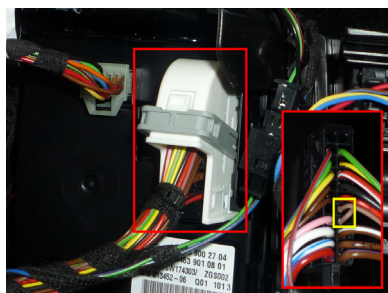

Figure 45

The module is connected by cutting into the CAN-bus going to the KLA unit (series connection). The module CAN-1 twisted pairs and CAN-3 must be connected to the vehicle's CAN-bus as follows: CAN-3 is connected towards the KLA unit and CAN1-1 towards the vehicle's side (opposite direction).

In order to avoid factory wiring damage, It is recommended to disassemble the relevant vehicle's connector (at the KLA unit) and then assemble it back using the connector adapters included in a standard kit. For more detailed connection description refer to diagram 1.

The climatic system is activated with the last settings that had been used before the ignition was turned off.

! If the vehicle is equipped with factory PTC air heaters, they must be disabled while the FanControl module is running.

Factory parking heater

The module is connected to the vehicle's CAN-bus in any convenient place e.g. beside the KLA unit (figure 44). The module CAN1 twisted pair is used. It is also required to connect the LIN-bus, the connection is performed right beside the KLA unit (white connector, figure 45).

The LIN connection is performed by cutting into the vehicle's LIN-bus (series connection)-pin №14 of the KLA unit, see figure 46. For more detailed connection description refer to diagram 3.

LIN-1 (grey/green wire) is connected towards the KLA unit.

LIN-2 (grey/blue wire) is connected towards the vehicle's side (opposite direction).



The climate control unit is activated simultaneously with factory parking heater. The climate control unit is activated in the standard blowing mode designed by the vehicle's manufacturer and with the last air temperature settings that had been used before the ignition was turned off.

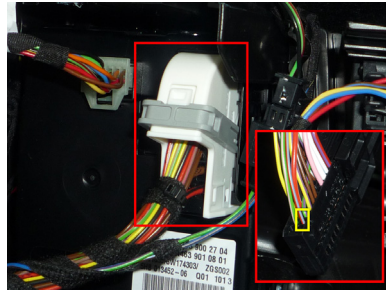

Figure 46

Mercedes-Benz 257

Group 9, subgroup 5

Vehicle's CAN-bus:

- CAN-L – brown
- CAN-H – brown or brown/red

Standard control button:

- Central locking «lock» button located on driver's door

Control of an aftermarket engine heater

The module is connected right by the KLA unit. The KLA unit is located behind the glove compartment (figures 47- 49).



Figure 47

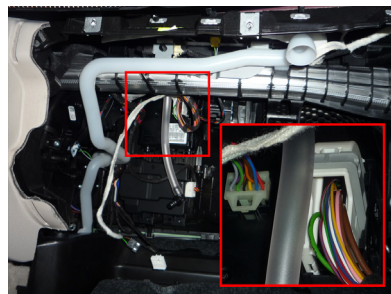

Figure 48

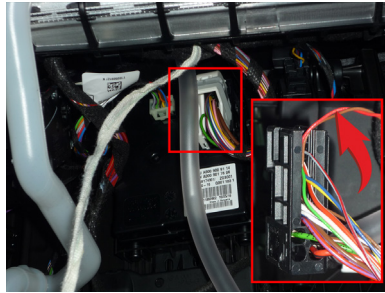

Figure 49

The connection to the CAN-bus of the KLA unit is performed in series. CAN1 and CAN3 of the module should be connected as follows: CAN3 to the KLA unit and CAN1 to the opposite direction (to the vehicle). It is recommended to disassemble the connector of the KLA unit, make all necessary connections to the CAN-bus using the special plastic plugs supplied with the device and then reassemble it (figures 11-15). This connection method helps prevent damaging the original vehicle wiring. Refer to the diagram 1 for connection details.

The module allows to activate the climate control unit in the last mode used before switching the ignition OFF and to simultaneously actuate an aftermarket engine heater.

- ! If the vehicle is equipped with factory PTC air heaters, they must be disabled while the FanControl module is running.

Controlling a factory parking heater

The module can be connected to the vehicle's Can-bus in any location, for instance to the twisted pair of the KLA unit (figure 49). CAN 1 of the module is connected in parallel.

The connection to LIN-bus is also required. The LIN-bus of the module should be connected to the vehicle's LIN-bus which is located in the white connector (figure 48) of the KLA unit as follows:

LIN1 (grey/green wire) and LIN2 (grey/blue wire) are connected to the vehicle's LIN-bus (pin №14, figure 50) in series. LIN1 is connected to the KLA unit and LIN2 to the opposite side of the LIN-bus (to the vehicle). Refer to the diagram 3 for details.

- ! The climate control unit is activated simultaneously with factory parking heater. The climate control unit is activated in the standard blowing mode designed by the vehicle's manufacturer and with the last air temperature settings that were used before switching off the ignition.

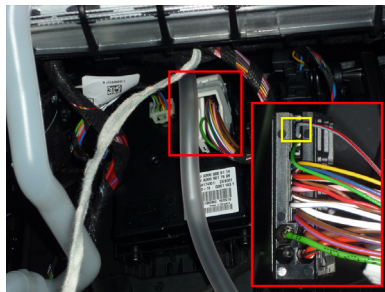

Figure 50

Mercedes-Benz 167 GLE/GLS, 253 GLC (2019--)

Group 9, subgroup 5

Vehicle's CAN-bus:

- CAN-L – brown
- CAN-H – brown or brown/red

Standard control button:

- Central locking «lock» button located on driver's door

Control of an aftermarket engine heater

The module is connected directly to the KLA unit. The KLA unit is located behind the glove compartment (figures 51 - 53).

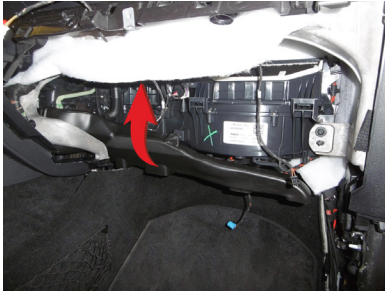

Figure 51

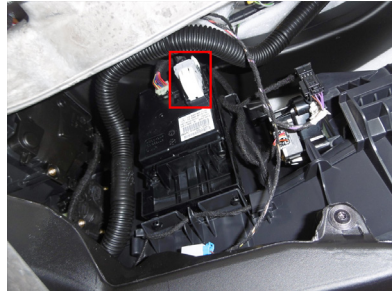

Figure 52

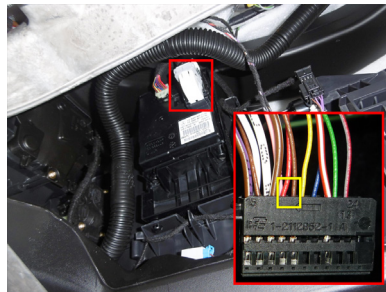

Figure 53

The connection to the CAN-bus of the KLA unit is performed in series. CAN1 and CAN3 of the module should be connected as follows: CAN3 to the KLA unit and CAN1 to the opposite direction (to the vehicle). It is recommended to disassemble the connector of the KLA unit, make all necessary connections to the CAN-bus using the special plastic plugs supplied with the device and then reassemble it (figures 11-15). This connection method helps prevent damaging the original vehicle wiring. Refer to the diagram 1 for connection details.

The module allows to activate the climate control unit in the last mode used before switching the ignition OFF and to simultaneously actuate an aftermarket engine heater.



If the vehicle is equipped with factory PTC air heaters, they must be disabled while the FanControl module is running.

To prevent the PTC air heaters from activating - the LIN-bus (figure 54) should be cut in half through a relay while the FANcontrol module is running.

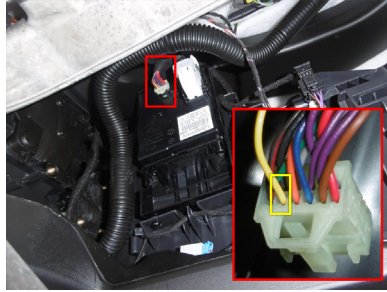

Figure 54

Controlling a factory parking heater (only for MB 253 (GLC, 2019--))

The module can be connected to the vehicle's Can-bus in any location, for instance to the twisted pair of the KLA unit (figure 53). CAN 1 of the module is connected in parallel.

The connection to LIN-bus is also required. The LIN-bus of the module should be connected to the vehicle's LIN-bus which is located in the white connector (figure 52) of the KLA unit as follows: LIN1 (grey/green wire) and LIN2 (grey/blue wire) are connected to the vehicle's LIN-bus (pin №14, figure 55) in series. LIN1 is connected to the KLA unit and LIN2 to the opposite side of the LIN-bus (to the vehicle). Refer to the diagram 3 for details.

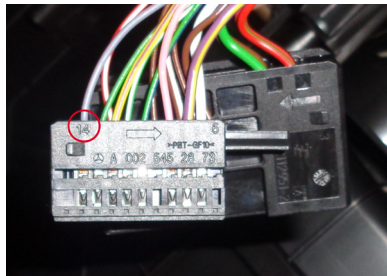

Figure 55

! The climate control unit is activated simultaneously with factory parking heater. The climate control unit is activated in the standard blowing mode designed by the vehicle's manufacturer and with the last air temperature settings that were used before switching off the ignition.

Installing the module in Mercedes-Benz Sprinter (907)

<p>Group 9, subgroup 5 Vehicle's CAN-bus:</p> <ul style="list-style-type: none"> • CAN-L – brown • CAN-H – red or brown with a red stripe 	<p>Standard control button:</p> <ul style="list-style-type: none"> • Central locking «lock» button located on driver's door
--	---

Controlling a factory parking heater

! Controlling a factory auxiliary engine heater is not supported.

The system switches on a factory parking heater to warm up the engine and interior. Connection to the vehicle's CAN bus can be made in any place, i.e. behind the left kick-panel (figure 56).

CAN1 of the module should be connected to the vehicle's CAN bus in parallel. LIN bus should be connected in series to the LIN bus of the KLA panel connector (figure 57).

Refer to the diagram 8 for connection details. LIN 2 of the module (grey/blue wire) connects to the climate control panel. LIN 1 (grey/green wire) connects to the opposite end of the LIN bus (to the vehicle).

 The climate control system activates in the standard "blowing" mode designed by the vehicle manufacturer.

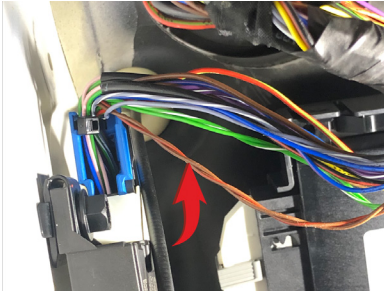

Figure 56

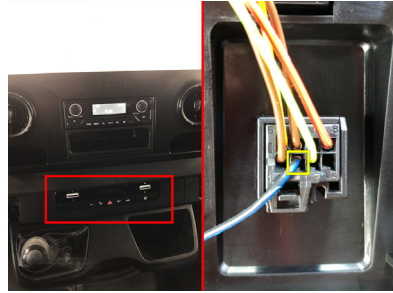

Figure 57

Diagram 1

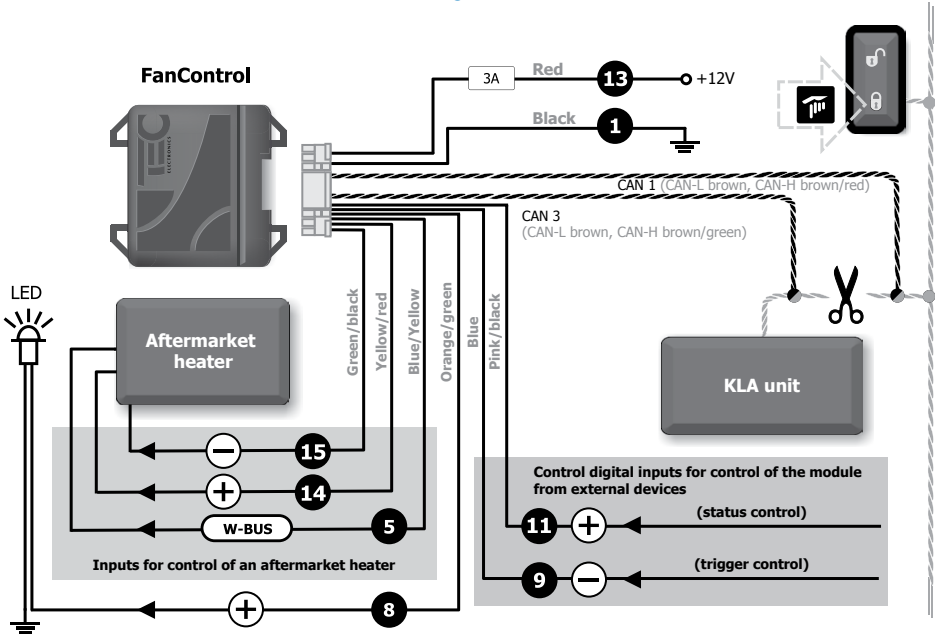

Diagram 2

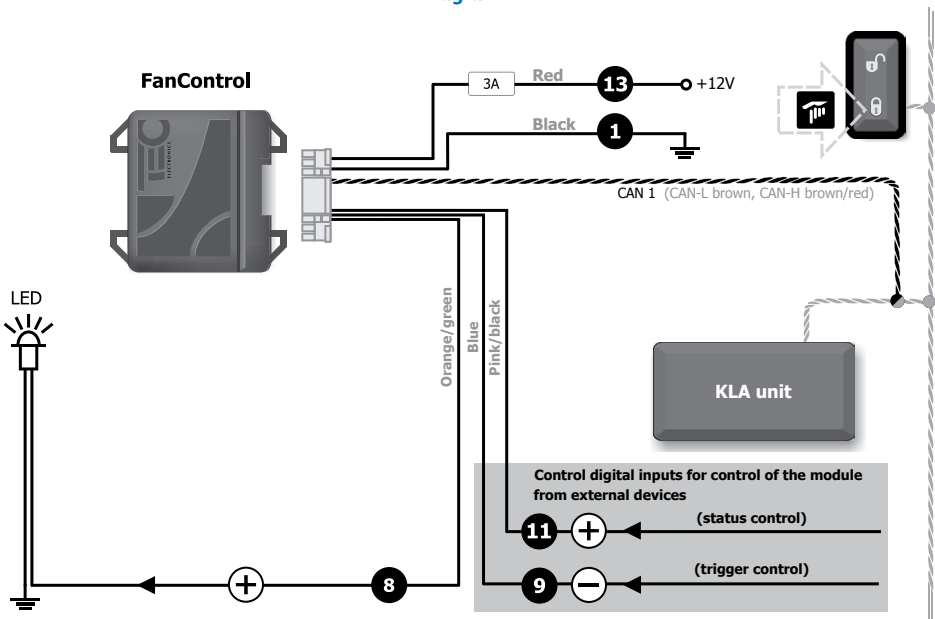

Diagram 3

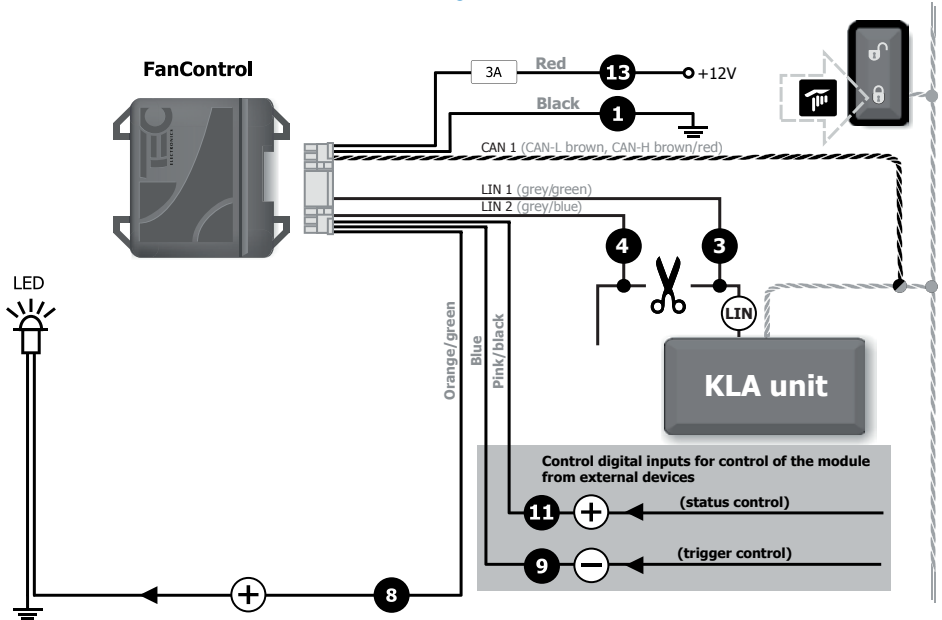

Diagram 4

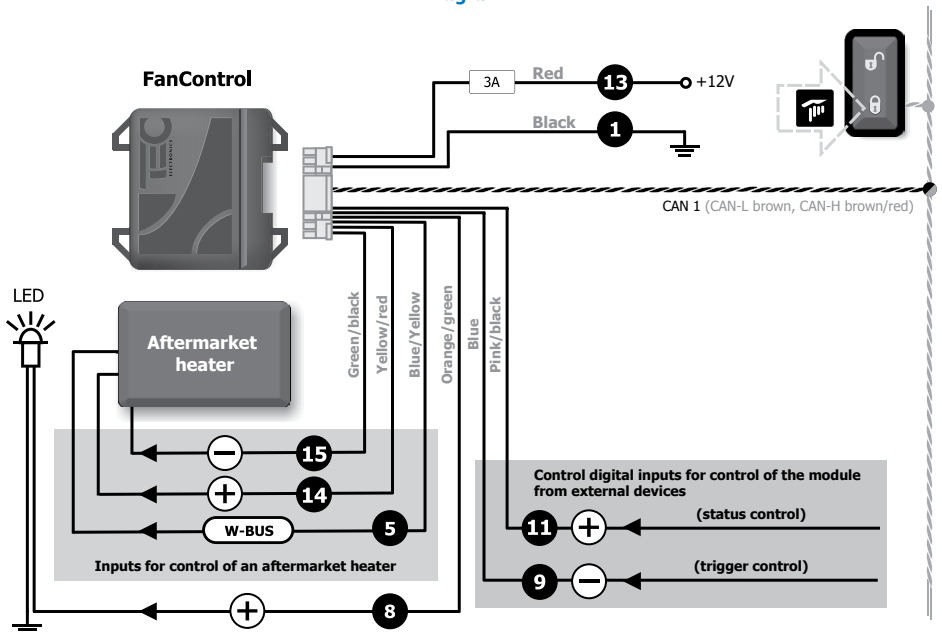

Diagram 5

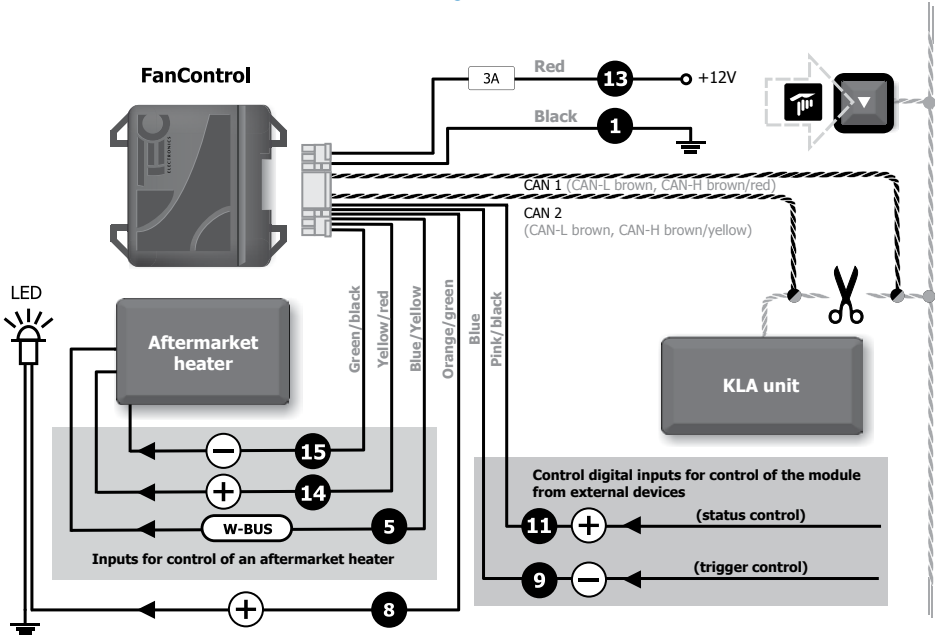

Diagram 6

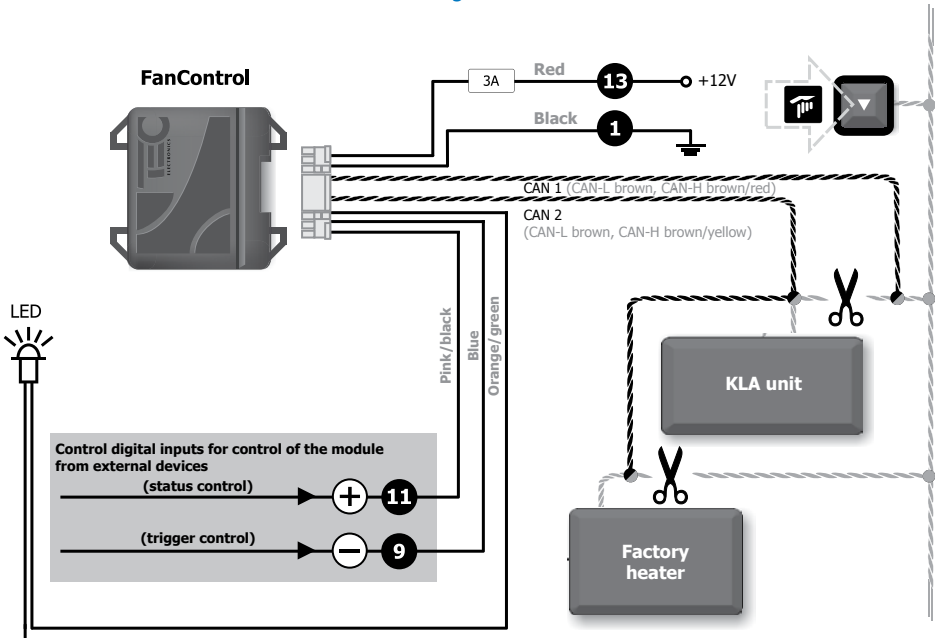

Diagram 7

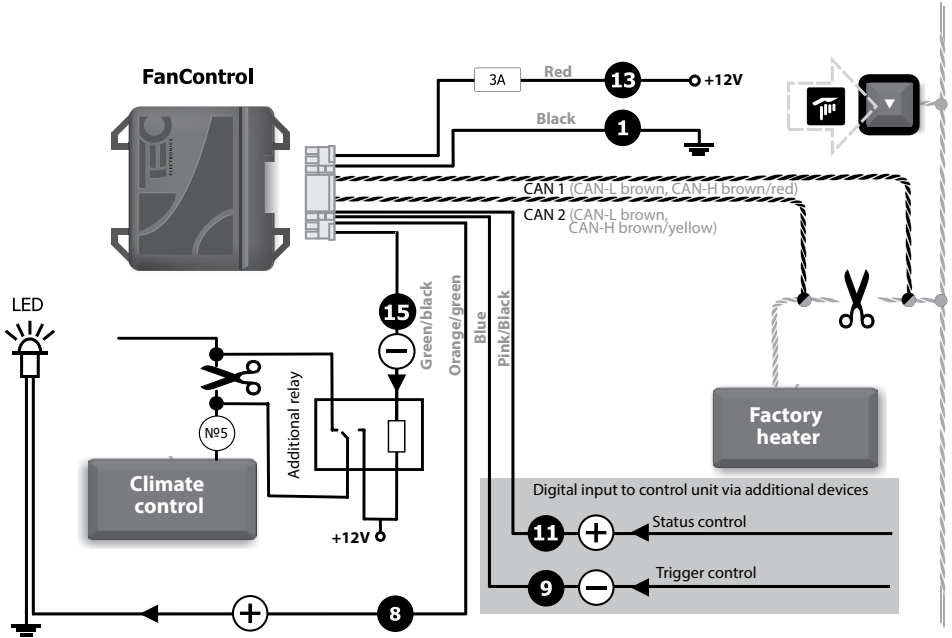

Diagram 8

