

Video inserter HDV-IVI16 / HDA-IVI16

Compatible with
Opel vehicles with IVI-R2
multimedia navigation system with 16inch touch monitor
Renault vehicles with Open R-Link
with vertical 10.4inch touch monitor



Examples

Attention!
The video signal type for each
video source must be defined in
the OSD menu of the
corresponding video input.

Product features

- 1 x CVBS/AHD input for rear-view camera
- 1 x CVBS/AHD input for front camera
- 2 x CVBS/AHD input for side cameras or additional after-market video-sources (e.g. USB devices, DVB-T2 tuner, etc.)
- All inputs are compatible with NTSC and PAL
Supported AHD resolutions 720p NTSC (30Hz), 720p PAL (25Hz), 960p NTSC (30Hz), 960p PAL (25Hz), 1080p NTSC (30Hz), 1080p PAL (25Hz)
- **HDV-IVI16 only:** 1 HDMI input for HD rear-view camera or other HDMI source (e.g. iOS/Android device, laptop, streaming stick, DVB-T2 tuner, etc.)
Supported HDMI resolutions (720p NTSC (60Hz), 720p PAL (50Hz), 1080p NTSC (60Hz), 1080p PAL (50Hz))
- **HDV-IVI16 only:** Analogue audio output for the HDMI source
- Automatic switchover to rear-view camera input while reverse gear is engaged
- Automatic front camera switching while reverse gear is engaged for 5, 10, 15 or 20- second intervals
- Adjustable guide lines (fixed or movable) for rear-view camera can be activated (movable guide lines not available for all vehicles)
- Picture free while driving (ONLY for fed-in video sources)

Table of contents

| | | |
|-----------|---|-----------|
| 1 | Before installation | 4 |
| 1.1 | Scope of delivery | 4 |
| 1.2 | Checking the interface compatibility with the vehicle and accessories | 5 |
| 1.3 | Boxes and connections – interface | 6 |
| 1.4 | Settings – 8 dip switch bench (interface functions) | 7 |
| 1.4.1 | Interface video inputs "V1-Left" and "V2 Right" (Dip 1-2) | 7 |
| 1.4.2 | Front camera input "V3 front" (Dip 3) | 7 |
| 1.4.3 | Rear-view camera settings (Dip 4) | 8 |
| 1.4.4 | Rear-view camera connection type (Dip 5) | 8 |
| 1.4.5 | HDMI input (Dip 6) | 8 |
| 1.4.6 | Vehicle selection: Left-hand or right-hand drive (Dip 8) | 8 |
| 1.5 | Settings – 2 dip switch bench (system-related setting) | 9 |
| 1.6 | Settings – 4 dip switch bench (system-related setting) | 9 |
| 1.7 | Settings – 4 dip switch bench (CAN bus) | 10 |
| 2 | Installation | 10 |
| 2.1 | Place of connection | 10 |
| 2.2 | Connection schema | 11 |
| 2.2.1 | Connection schema IVI R2 with 16inch monitor | 11 |
| 2.2.2 | Connection schema Open R-Link with vertical 10.4inch monitor | 12 |
| 2.3 | Connection – picture signal cable | 13 |
| 2.3.1 | Connection IVI R2 with 16inch monitor – picture signal cable | 13 |
| 2.3.2 | Open R-Link connection with vertical 10.4inch monitor – picture signal cable | 14 |
| 2.4 | Connection – cable sets, power supply and CAN bus or analogue without CAN bus | 15 |
| 2.4.1.1 | Connection IVI R2 with 16inch monitor – cable sets, power supply and CAN bus or analogue without CAN bus | 15 |
| 2.4.1.2 | Open R-Link with vertical 10.4inch monitor – cable sets, power supply and CAN bus or analogue without CAN bus | 16 |
| 2.4.2 | Connection with CAN bus | 17 |
| 2.4.2.1 | Connection IVI R2 with 16inch monitor with CAN bus | 17 |
| 2.4.2.2 | Connection Open R-Link with vertical 10.4inch monitor with CAN bus | 18 |
| 2.4.2.2.1 | Place of connection for power/CAN Open R-Link with vertical 10.4inch monitor | 19 |
| 2.4.3 | Analogue connection without CAN bus | 20 |
| 2.4.3.1 | Analogue connection IVI R2 with 16inch monitor without CAN bus | 20 |
| 2.4.3.2 | Analogue connection Open R-Link with vertical 10.4inch monitor without CAN bus | 21 |
| 2.5 | Power supply outputs | 22 |
| 2.5.1 | Connection and power supply – video sources Rear-view camera, front camera and 2 side cameras | 23 |
| 2.5.2 | Connection and power supply - Video sources rear-view camera, front camera and 2 video sources | 24 |
| 2.6 | Aftermarket rear-view camera | 25 |
| 2.6.1 | Case 1: Reverse gear signal from CAN bus | 25 |
| 2.6.2 | Case 2: Reverse gear signal from analogue signal | 26 |
| 2.7 | Aftermarket front camera | 27 |
| 2.8 | Aftermarket side cameras | 28 |
| 2.8.1 | Case 1: Turn signals from CAN bus | 28 |
| 2.8.2 | Case 2: turn signals from analogue signal | 29 |
| 2.9 | HDMI rear-view camera or other HDMI sources (HDV-IVI16 only) | 30 |
| 2.10 | Audio insertion | 31 |
| 2.11 | Connection - Video interface and external keypad | 31 |
| 2.12 | settings OSD menu | 32 |
| 3 | Operating the video interface | 36 |
| 3.1 | Optional: Operating the video interface via the "HDA-RC" remote control | 36 |

Manual

| | |
|---|-----------|
| 4 Specifications | 37 |
| 5 FAQ – Troubleshooting Interface functions – product-specific | 37 |
| 6 FAQ - Troubleshooting Interface functions - general | 38 |
| 7 Technical Support | 40 |

Legal notice

The driver must not be distracted directly or indirectly by moving pictures while driving. In most countries/states, this is prohibited by law. We therefore accept no liability for damage to property or personal injury caused directly or indirectly by the installation and operation of this product. In addition to operation when stationary, this product is only intended for displaying static menus (e.g. MP3 menus from USB devices) or pictures from (rear-view) cameras while driving.

Changes/updates to the vehicle software may impair the functionality of the interface. Software updates for our interfaces are provided to customers free of charge for up to one year after purchase of the interface. The interface must be sent in free of charge for the update. Costs for installation and removal will not be reimbursed.

1 Before installation

These instructions must be read before installation. Specialist knowledge is required for installation. The interface must not be installed near sources of moisture or heat.

Before final installation in the vehicle, we recommend a test run after connection to ensure that the vehicle and interface are compatible. Due to production-related changes by the vehicle manufacturer, there is always the possibility of incompatibility.

1.1 Scope of delivery

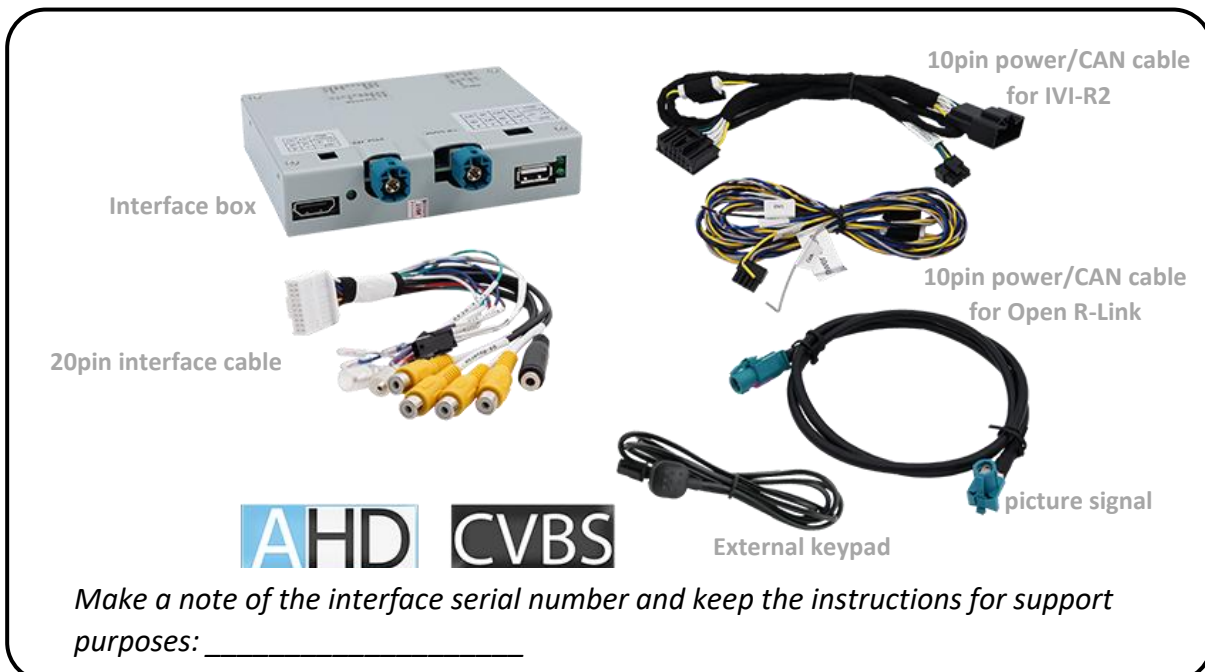

1.2 Checking the interface compatibility with the vehicle and accessories

Requirements

| Manufacturer | Compatible vehicles | Compatible systems |
|----------------|---|---|
| Opel | Grandland B from approx. 09/2024 | IVI-R2 – Multimedia navigation system with 16inch touch monitor |
| Renault | Captur II facelift from approx. 06/2024 Symbioz from approx. 09/2024 | Open R-Link with vertical 10.4inch touch monitor |

Limitations

CAN bus compatibility

The CAN bus compatibility of the interface may be restricted for some vehicles, either completely or for individual functions. This may become apparent during installation or at a later date.

The interface with all video inputs can be operated with analogue switch signals without being connected to the vehicle's CAN bus. In this case, individual additional functions are not available, see chapter 2.4.3 *Analogue connection without CAN bus*

Analogue connection IVI R2 with 16inch monitor without CAN bus .

Video only

interface **does not** feed in **any** audio signals. To insert audio signals, any existing factory audio AUX input or optional products must be used (e.g. FM modulator). For an inserted HDMI source, audio is output via an analogue audio output (3.5 mm jack socket).

Factory rear-view camera

Automatic switching to rear-view camera input only occurs while reverse gear is engaged. Optional accessories are required for different switching times.

Aftermarket front camera

Switching to the front camera occurs automatically after reverse gear has been engaged for 5, 10, 15 or 20 seconds (depending on the OSD menu setting). Manual switching to the front camera is also possible via the external keypad.

Guide lines for rear-view camera

If the vehicle CAN bus is not fully compatible with the interface or if an analogue connection is used, the movable guide lines function cannot be used.

1.3 Boxes and connections – interface

The video interface converts video signals from after-market sources into a video signal compatible with the factory head unit. This is inserted into the factory monitor via various switching options. It also reads digital signals from the vehicle CAN bus and converts them for its own functions.

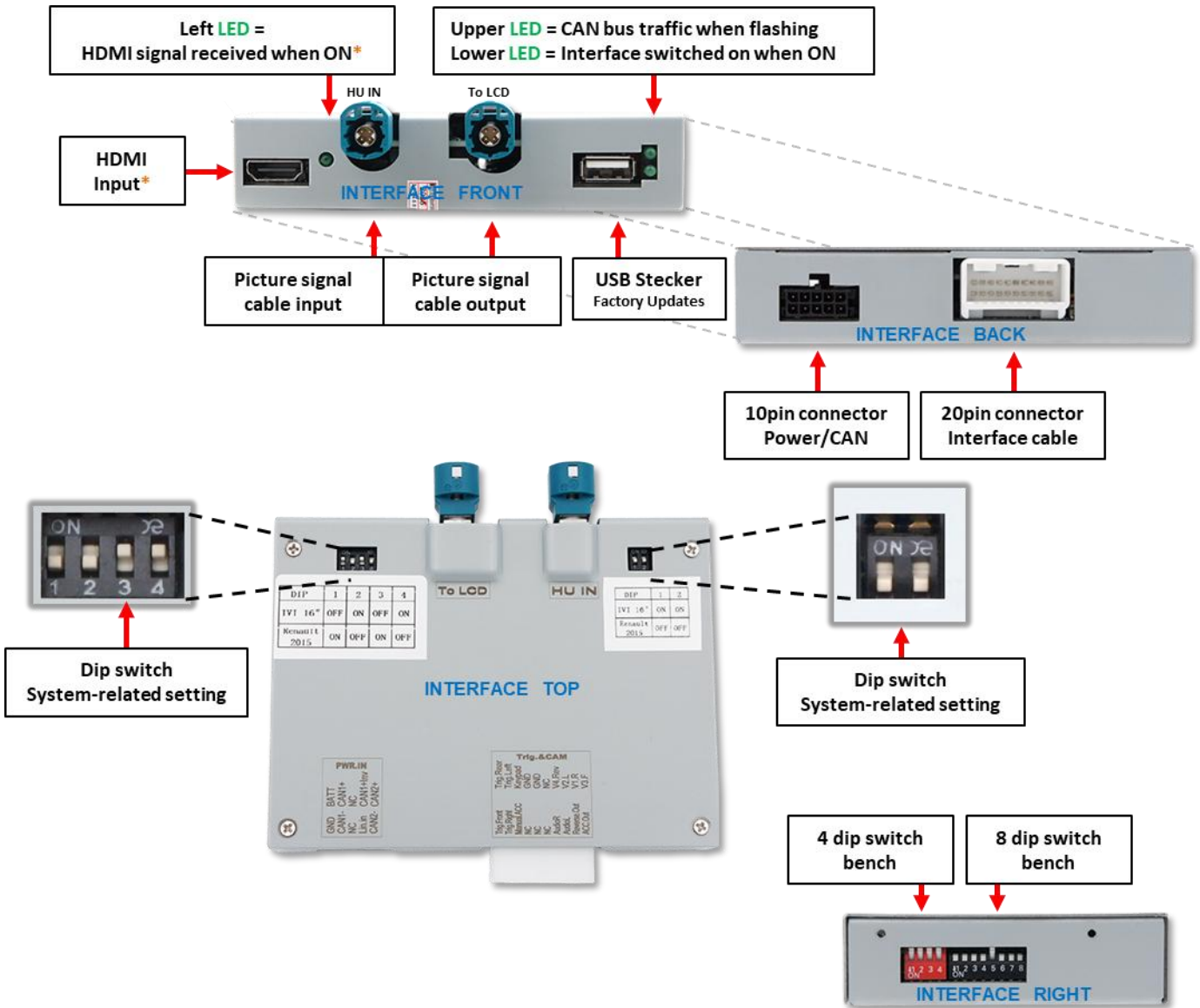

* HDMI input only available with HDV-IVI16

1.4 Settings – 8 dip switch bench (interface functions)

Interface box, right side, black

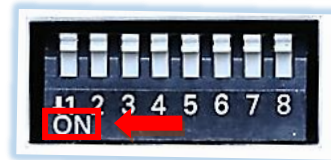

Dip position **UP = OFF (up)** and **DOWN = ON (down)**

| Dip | Function | ON (down) | OFF (up) |
|-----|--|--|--------------------------------------|
| 1 | Video 1 / V1-Left | activated | deactivated |
| 2 | Video 2 / V2-Right | activated | deactivated |
| 3 | Front camera / V3-Front | activated* | deactivated |
| 4 | Type of rear-view camera (V4 Reverse) | Aftermarket | Factory or none |
| 5 | Connection type of the Aftermarket rear-view camera* | HDMI* | V4 Reverse (CVBS/AHD) |
| 6 | HDMI input* | Enabled | deactivated |
| 7 | No function | - | Set to OFF |
| 8 | Vehicle: Left-hand or right-hand drive | Steering wheel on the right-hand side (UK, etc.) | Steering wheel on the left hand side |

Power reset interface after each dip change to activate changes!

* Switching to the front camera occurs automatically for 5, 10, 15 or 20 seconds (depending on the OSD menu setting) after reverse gear is engaged.

* On the **HDA-IVI16**, dip switches 5 and 6 have no function. Set them to **OFF**.

See following chapters for detailed information about 8dip switch bench.

1.4.1 Interface video inputs "V1-Left" and "V2 Right" (Dip 1-2)

With Dip 1 (Dip 2) = **ON**, the CVBS/AHD input **V1-Left** (**V2 Right**) is activated for the side camera or other video sources. Only activated video inputs can be accessed – both with automatic and manual switching. It is recommended to activate only inputs that are in use, to avoid accidental switching.

1.4.2 Front camera input "V3 front" (Dip 3)

When Dip 3 = **ON**, the interface switches to the CVBS/AHD front camera input **V3-Front** after reverse gear is engaged. In addition, manual switching to the front camera input is possible from any picture mode via an external keypad (short press).

In the OSD menu settings, the automatic display time of the front camera can be selected between 5, 10, 15 or 20 seconds or switched off. Then another video source could also be connected to instead of a front camera.

1.4.3 Rear-view camera settings (Dip 4)

When Dip 4 = **OFF**, the interface switches to the factory image for the existing factory rear-view camera or factory PDC display as long as reverse gear is engaged.

With Dip 4 = **ON**, the interface switches to its FBAS/AHD rear-view camera input **V4-Reverse** (provided Dip 5 is set to OFF) or the **HDMI** input* (provided Dip 5 and Dip 6 are set to **ON**) when reverse gear is engaged.

Note: **V4-Reverse** remains inactive when Dip 5 = ON and an HDMI camera is used, resulting in no function.

1.4.4 Rear-view camera connection type (Dip 5)

With Dip 5 = **ON**, the **HDMI** input* is selected as the rear-view camera input. In addition, the **HDMI** input* must be activated with Dip 6 = **ON**.

With Dip 5 = **OFF**, the **V4 -Reverse** input is selected as the rear-view camera input.

Note: Automatic switching to the front camera for the preset time occurs in both cases after reverse gear is engaged.

1.4.5 HDMI input (Dip 6)

With Dip 6 = **ON**, the **HDMI** input* is activated and can be used for various HDMI sources (e.g. rear-view camera or 360° camera system, smartphone, laptop, streaming stick, DVB-T2 tuner, etc.) . For rear-view camera/360° camera system, Dip 5 must also be set to **ON**.

With Dip 6 = **OFF**, the **HDMI** input* is deactivated.

Note: Dip 7 has no function and must be set to OFF.

1.4.6 Vehicle selection: Left-hand or right-hand drive (Dip 8)

Dip 8 is used to set whether the vehicle's steering wheel is on the left or right side (e.g. in the UK). Dip 8 = **ON** for **right-hand drive**, Dip 8 = **OFF** for **left-hand drive**.

Power reset interface after each dip change to activate changes!

* **HDMI input only available with HDV-IVI16**

1.5 Settings – 2 dip switch bench (system-related setting)

Interface box, top, black



Please note: Unlike the other switch banks (8 dip switch bench and 4 dip switch bench), the dip position **UP = ON** and **DOWN = OFF** for the 2 dip switch bench!

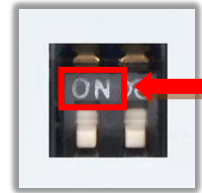

Caution!
Flip the dip switches very carefully with a micro tool.

| Monitor size | Dip 1 | Dip 2 |
|--|-------|-------|
| IVI-R2 with 16inch monitor | ON ↑ | ON ↑ |
| Open R-Link with vertical 10.4inch monitor | OFF ↓ | OFF ↓ |

Power reset interface after each dip change to activate changes!

1.6 Settings – 4 dip switch bench (system-related setting)

Interface box, top, black



Please note: Unlike the other switch banks (8-way and 4-way) the 4-way switch bank has the DIP position **UP = ON** and **DOWN = OFF** on the top!

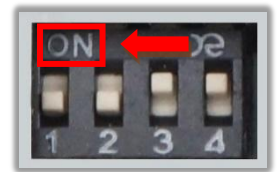

Attention!
Flip the dip switches very carefully with a micro tool.

| Head unit/monitor size | Dip 1 | Dip 2 | Dip 3 | Dip 4 |
|--|-------|-------|-------|-------|
| IVI-R2 with 16inch monitor | OFF ↓ | ON ↑ | OFF ↓ | ON ↑ |
| Open R-Link with vertical 10.4inch monitor | ON ↑ | OFF ↓ | ON ↑ | OFF ↓ |

Power reset interface after each dip change to activate changes!

1.7 Settings – 4 dip switch bench (CAN bus)

Interface box, right side, red

Set the DIP switch positions according to the following table.

Dip position **UP = OFF (up)** and **DOWN = ON (down)**

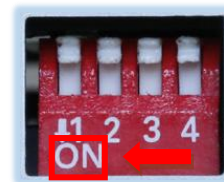

| Dip | Function | ON (down) | OFF (up) |
|-----|-------------|-----------|------------|
| 1 | No function | - | Set to OFF |
| 2 | No function | - | Set to OFF |
| 3 | No function | - | Set to OFF |
| 4 | No function | - | Set to OFF |

Power reset interface after each dip change to activate changes!

2 Installation

Switch off the ignition and disconnect the vehicle battery in accordance with the manufacturer's instructions!

If the vehicle battery must not be disconnected according to the manufacturer's specifications, it is usually sufficient to put the vehicle into sleep mode. If this does not work, disconnect the vehicle battery using a resistor cable.

Before final installation, we recommend a test run of the interface with all connected devices to ensure that all parts are compatible. Due to possible changes in the vehicle manufacturer's production at any time, incompatibility can never be ruled out.

As with any installation of retrofit devices, a quiescent current test of all retrofitted devices must be carried out after installation to ensure that the devices switch to standby mode when the vehicle is in sleep mode.

2.1 Place of connection

The video interface is connected to the rear of the head unit.

2.2 Connection schema



2.2.1 Connection schema IVI R2 with 16inch monitor

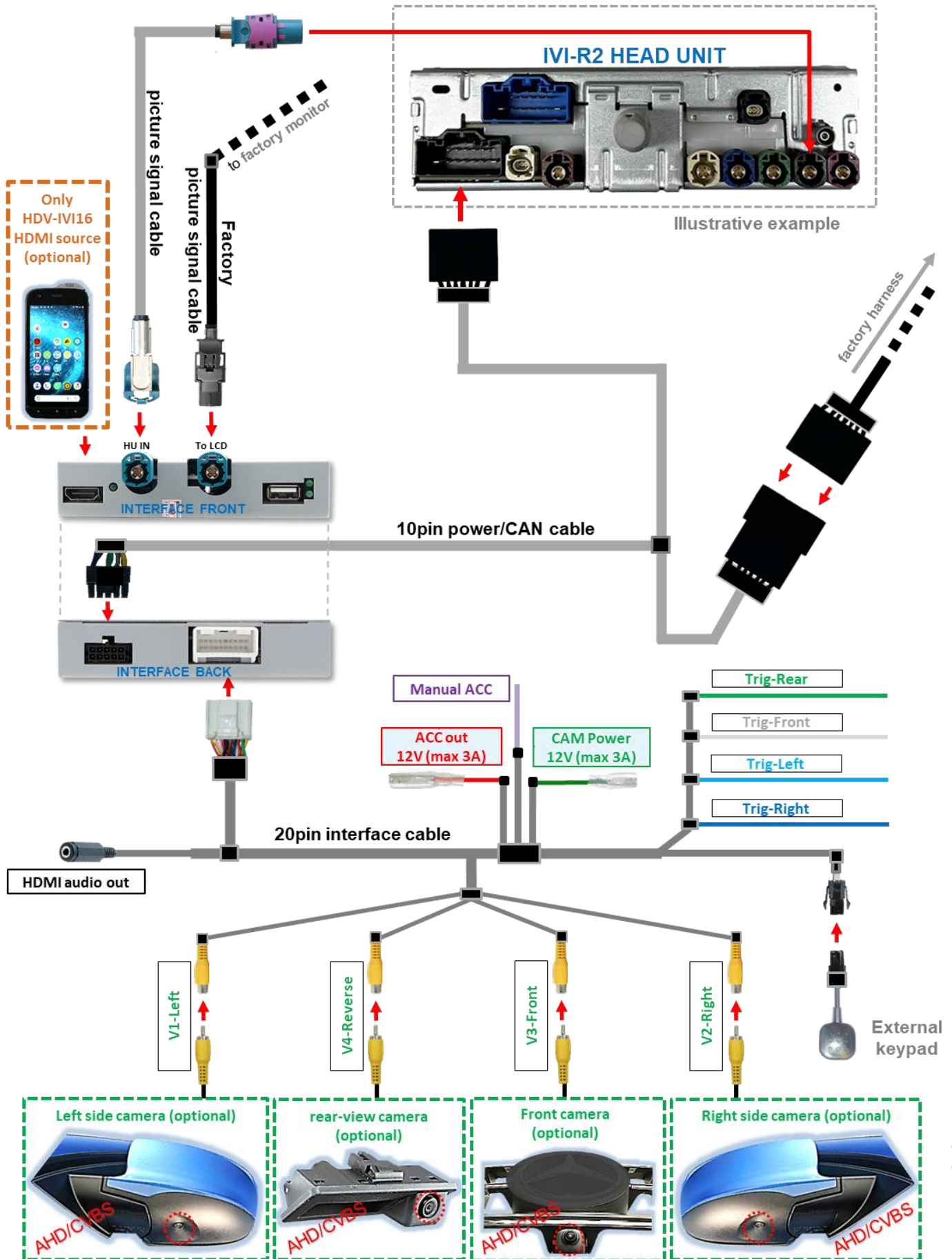

2.2.2 Connection schema Open R-Link with vertical 10.4inch monitor

Open R-Link

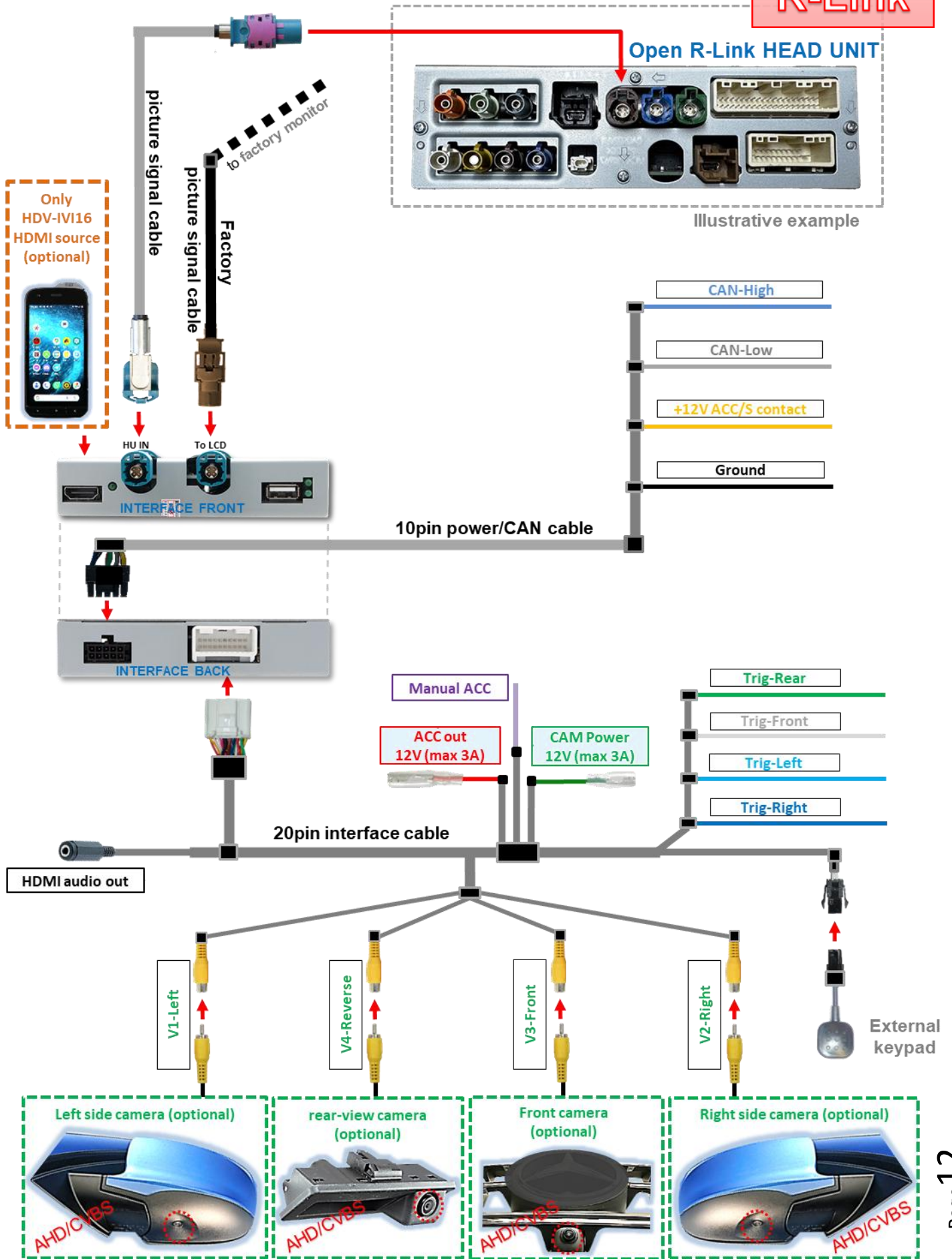

2.3 Connection – picture signal cable

2.3.1 Connection IVI R2 with 16inch monitor – picture signal cable

Remove the head unit.

IVI-R2

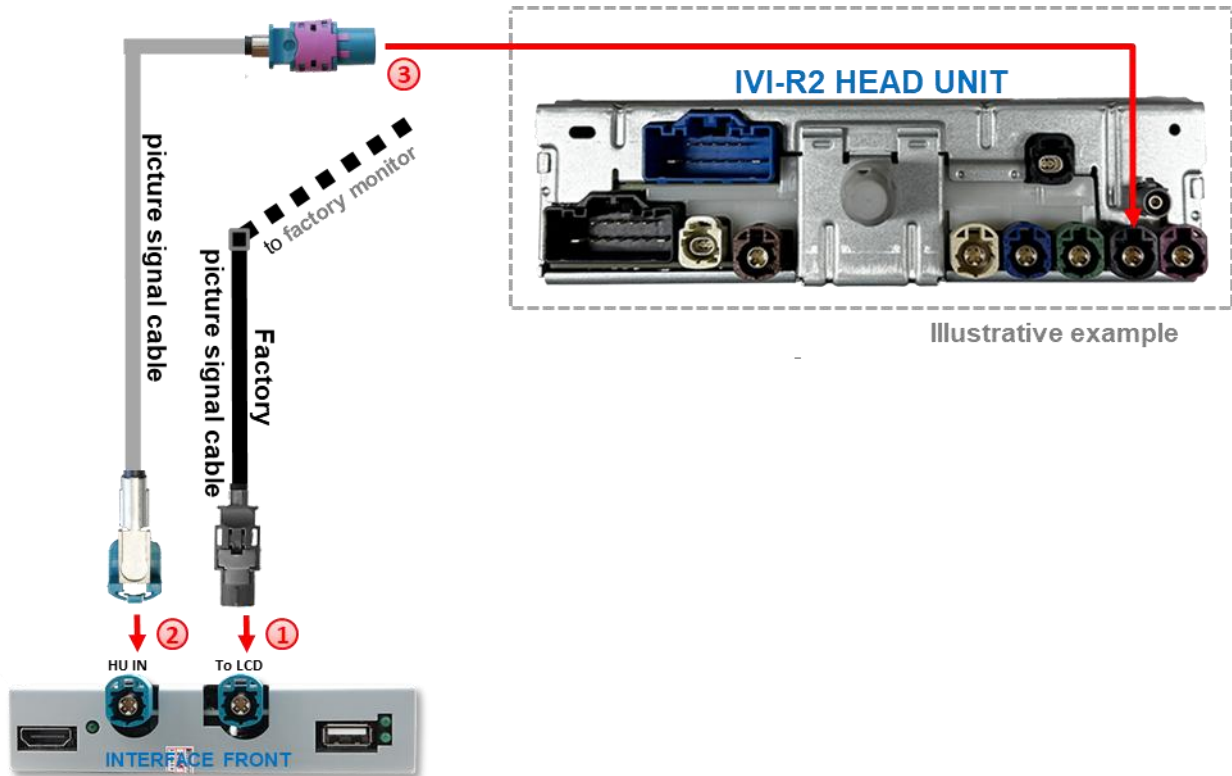

- 1** Unplug the **black** HSD female connector (colours may vary) of the factory picture signal cable on the rear of the head unit and connect it to the **aqua blue** HSD male connector "To LCD" of the interface.
- 2** Connect the **aqua blue** angled HSD female connector of the picture signal cable to the **aqua blue** HSD male connector "HU IN" on the interface.
- 3** Connect the **aqua blue** non-angled HSD female connector of the picture signal cable to the **black** HSD male connector of the head unit.



Note: Depending on the installation conditions, the supplied picture signal cable may also be installed twisted with regard to its HSD female connectors.

2.3.2 Open R-Link connection with vertical 10.4inch monitor – picture signal cable

Remove the head unit.

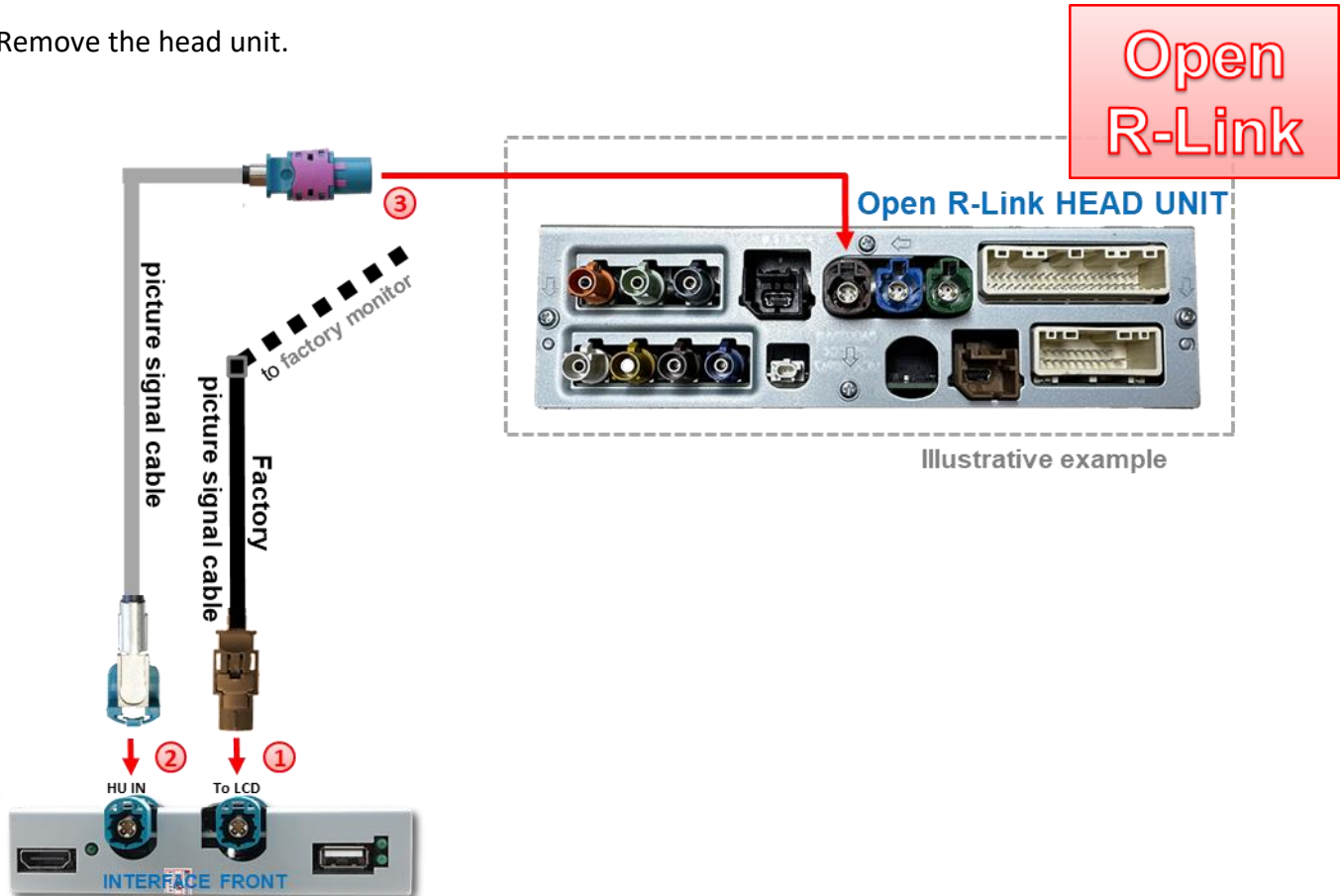

- 1 Unplug the **brown** HSD female connector (colours may vary) of the factory picture signal cable on the rear of the head unit and connect it to the **aqua blue** HSD male connector "TO LCD" on the interface.
- 2 Connect the **aqua blue** angled HSD female connector of the picture signal cable to the **aqua blue** HSD male connector "HU IN" on the interface.
- 3 Connect the **aqua blue** straight HSD female connector of the picture signal cable to the **brown** HSD male connector of the head unit.



Note: Depending on the installation conditions, the supplied picture signal cable may also be mounted twisted with regard to its HSD female connectors.

2.4 Connection – cable sets, power supply and CAN bus or analogue without CAN bus

The interface can be integrated via CAN bus or operated completely analogue without connection to the CAN bus.

When integrated via CAN bus, the interface is switched on via this bus and reverse gear signals and turn signals are usually detected from this. In some vehicles, movable guide lines can then also be displayed based on the CAN bus steering signals.

In exceptional cases, CAN communication is not (fully) compatible. If no interface LED lights up after connecting the **10pin power/CAN cable set** with the ignition switched on, the analogue connection described below must be made. The analogue connection is also possible in order to avoid a possible subsequent CAN bus incompatibility. In this case, the interface must be switched on and switched to its inputs via +12V switch inputs.

The display of movable guide lines for the rear-view camera is not available with an analogue connection.

2.4.1.1 Connection IVI R2 with 16inch monitor – cable sets, power supply and CAN bus or analogue without CAN bus

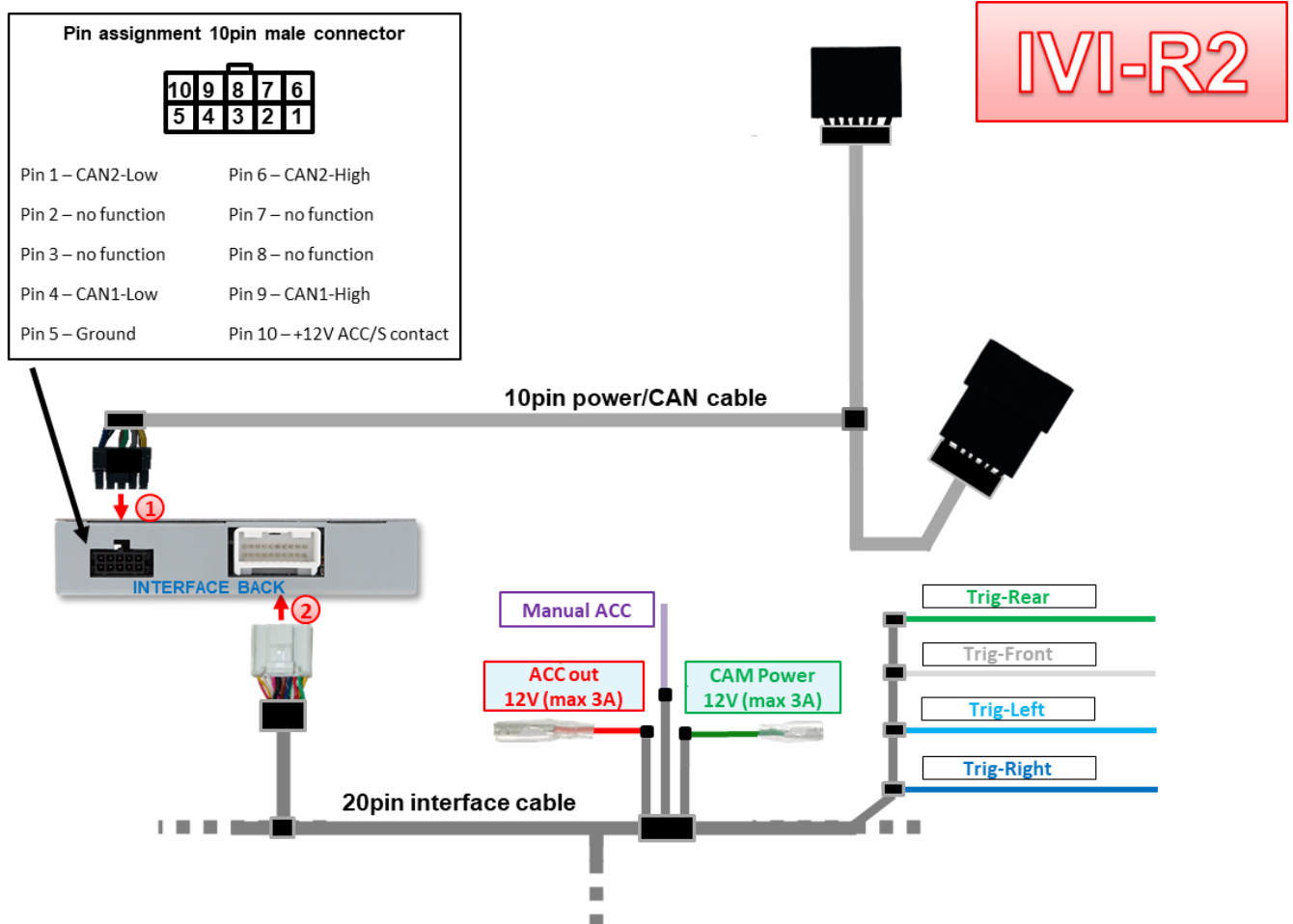

- 1 Connect the female connector of the **10pin power/CAN cable** to the 10pin male connector of the interface.
- 2 Connect the 20pin female connector of **the 20pin interface cable** to the 20pin male connector of the interface.

2.4.1.2 Open R-Link with vertical 10.4inch monitor – cable sets, power supply and CAN bus or analogue without CAN bus

Regardless of whether the connection is made with CAN bus or analogue without CAN bus, the **black ground wire** and the **yellow +12V ACC/S contact wire** of the 10pin power/CAN cable must always be connected.

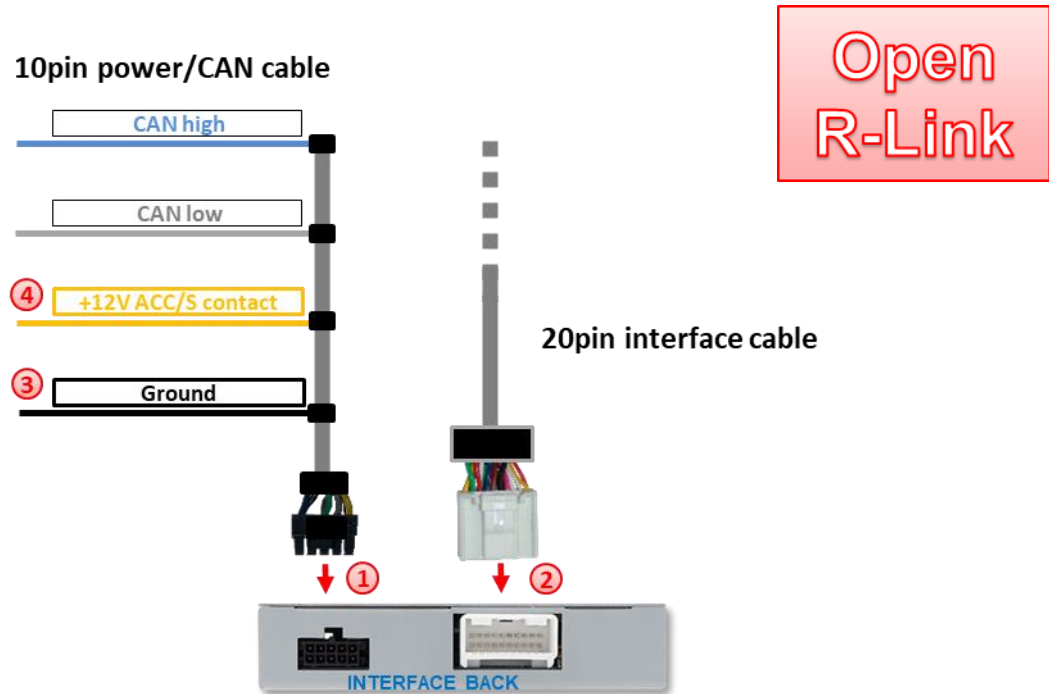

- 1 Connect the 10pin female connector of the 10pin power/CAN cable to the 10pin male connector of the interface.
- 2 Connect the 20pin female connector of the 20pin interface cable to the 20pin male connector of the interface.
- 3 Connect the black ground wire of the 10pin power/CAN cable to the vehicle ground.
- 4 Connect the yellow +12V ACC/S contact wire of the 10pin power/CAN cable to +12V ACC (terminal 15r) or S contact (terminal 86s) of the vehicle.



Note: Connection to the +12V battery (terminal 30) is also technically possible. However, in the event of (partial) CAN bus incompatibility or a defect, it cannot be ruled out that the interface will not switch off in sleep mode. Connection to the +12V battery (terminal 30) is at your own risk!

2.4.2 Connection with CAN bus

2.4.2.1 Connection IVI R2 with 16inch monitor with CAN bus

IVI-R2

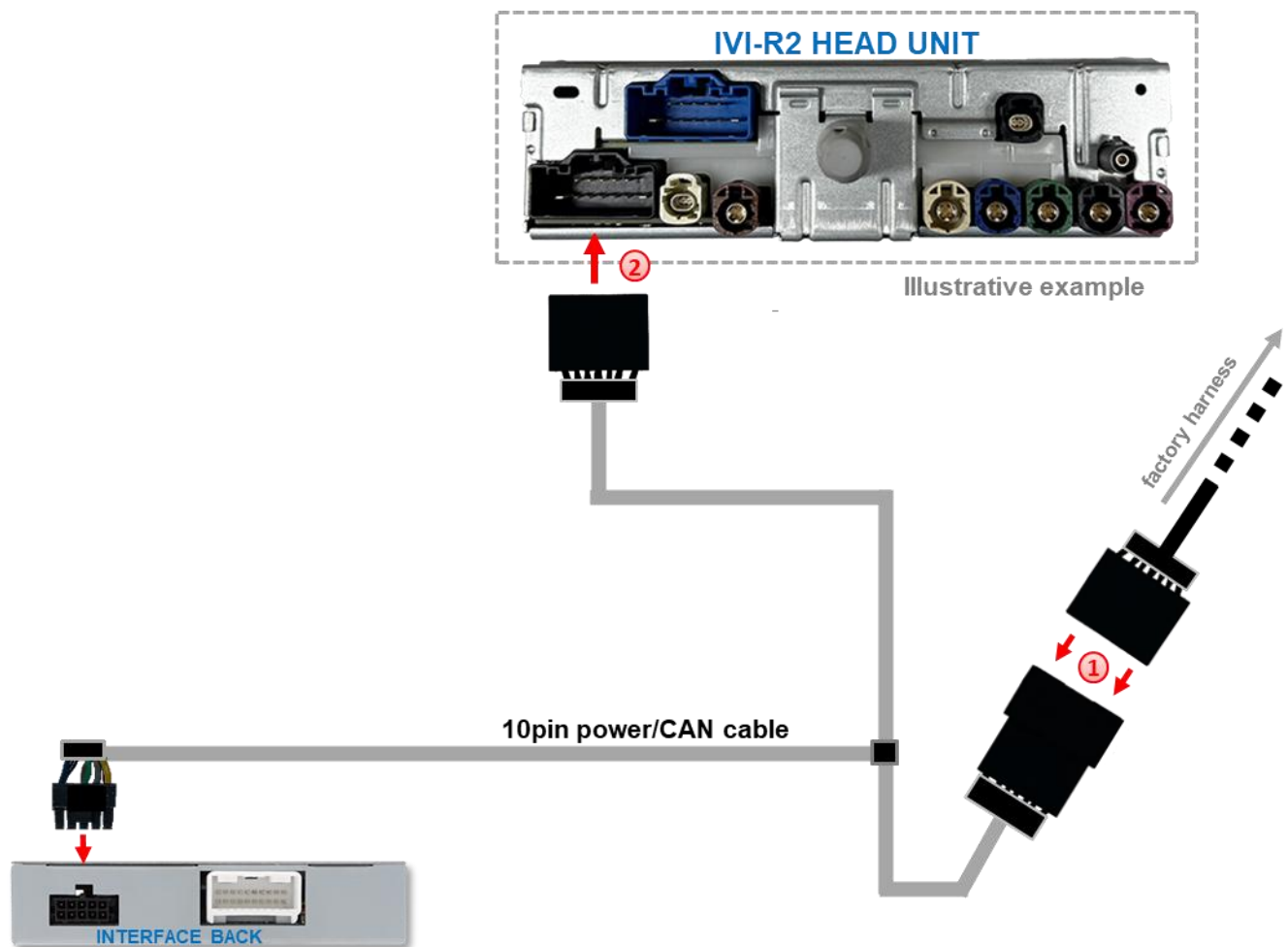

- 1 Unplug the 12pin female connector of the vehicle wiring harness on the back of the head unit and connect it to the black 12pin male connectors of the 10pin power/CAN cable.
- 2 Connect the opposite black 12pin female connectors of the 10pin power/CAN cable to the previously disconnected 12pin male connector of the head unit.

Caution!
In exceptional cases, CAN communication is not (fully) compatible. If, after connecting the 10pin power/CAN cable set with the ignition switched on, no interface LED lights up, the analogue connection described below must be made.

2.4.2.2 Connection Open R-Link with vertical 10.4inch monitor with CAN bus

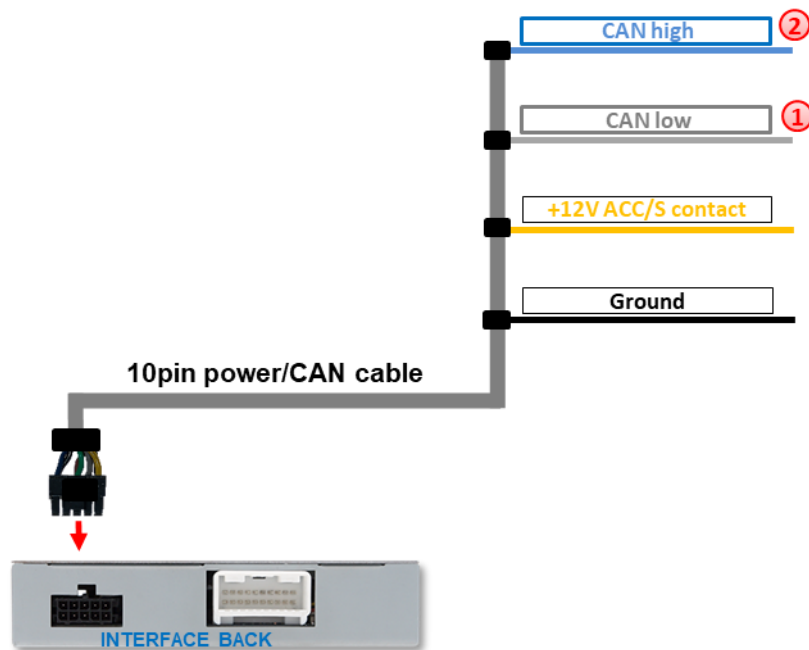

- 1 Connect the grey wire of the 10pin power/CAN cable to the vehicle's CAN Low (see possible places of connection below).
- 2 Connect the blue wire of the 10pin power/CAN cable to the vehicle's CAN High (see possible places of connection below).

Caution!
In exceptional cases, CAN communication is not (fully) compatible. If, after connecting the 10pin power/CAN cable set with the ignition switched on, no interface LED lights up, the analogue connection described below must be made.

2.4.2.2.1 Place of connection for power/CAN Open R-Link with vertical 10.4inch monitor

Open R-Link



Open R-Link head unit

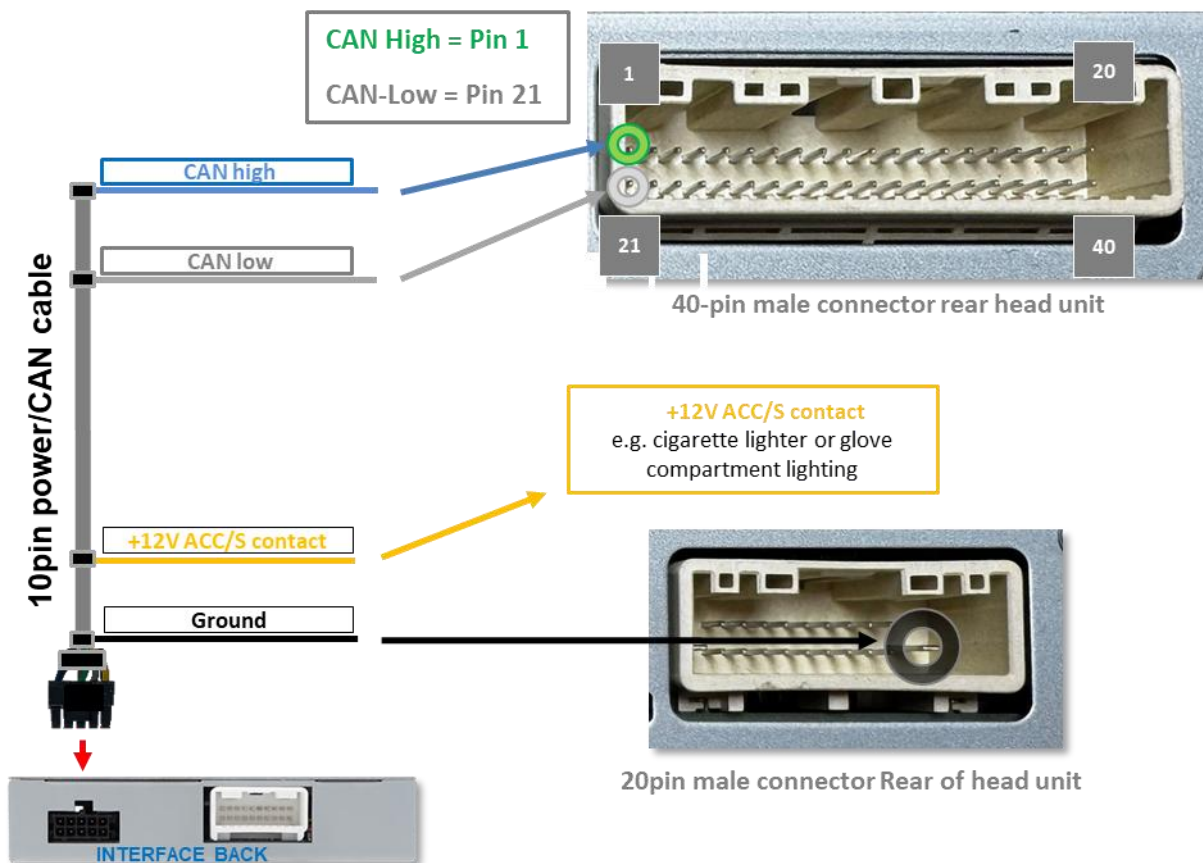

Please note: Cable colours in the vehicle may vary!

Note: Connection to a +12V battery (terminal 30) is also technically possible. However, in the event of (partial) CAN bus incompatibility or a defect, it cannot be ruled out that the interface will not switch off in sleep mode. Connection to a +12V battery (terminal 30) is at your own risk!

Attention!
In exceptional cases, CAN communication is not (fully) compatible. If no interface LED lights up after connecting the 10pin power/CAN cable set with the ignition switched on, the analogue connection described below must be made.

2.4.3 Analogue connection without CAN bus

2.4.3.1 Analogue connection IVI R2 with 16inch monitor without CAN bus

For analogue connection, the two CAN wires of the 10pin power/CAN cable are not connected – to do this, the two wires of the 10pin power/CAN cable must be separated!

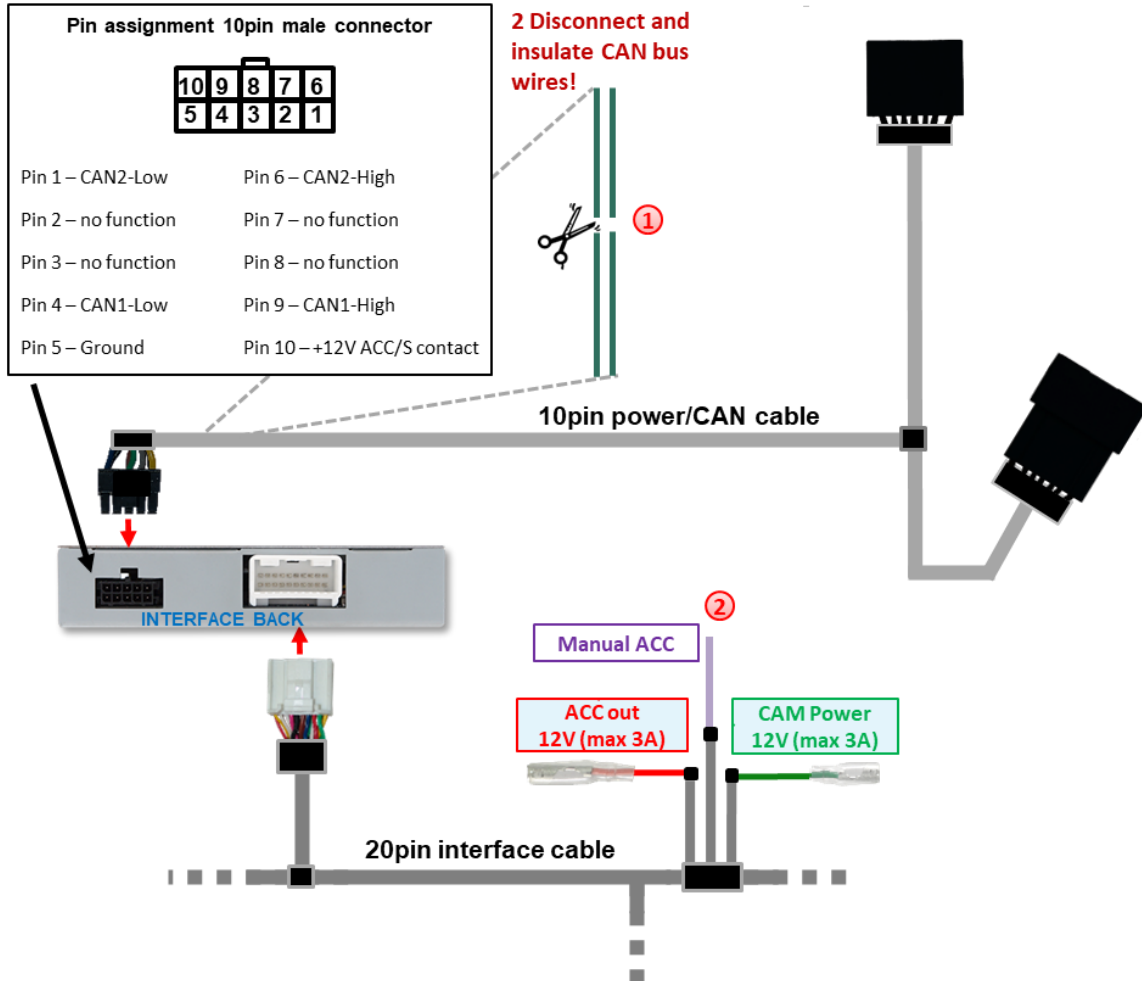

① Separate and insulate the two CAN bus wires (both green) of the 20pin interface cable approx. 4-5 cm behind the black male connector.

② Connect the purple Manual ACC wire of the 20pin interface cable to the +12V S contact (terminal 86s) or ACC terminal 15r (e.g. cigarette lighter, glove compartment light).



Notes

- The screen is only switched on as long as the video interface is switched on via +12V to Manual ACC. Otherwise, the factory picture is also black. When selecting the switch-on signal, check whether the factory picture is available in all desired operating states.
- The display of driving lines is not available with an analogue connection.
- If the interface is connected via analogue (without CAN bus), the rear-view camera and side cameras must also be connected via analogue.
See points:
2.6.2Case 2: Reverse gear signal from analogue signal
2.8.2Case 2: turn signals from analogue signal

2.4.3.2 Analogue connection Open R-Link with vertical 10.4inch monitor without CAN bus

With an analogue connection, the **blue CAN high wire** and grey CAN low wire of the 10pin power/CAN cable are not connected.

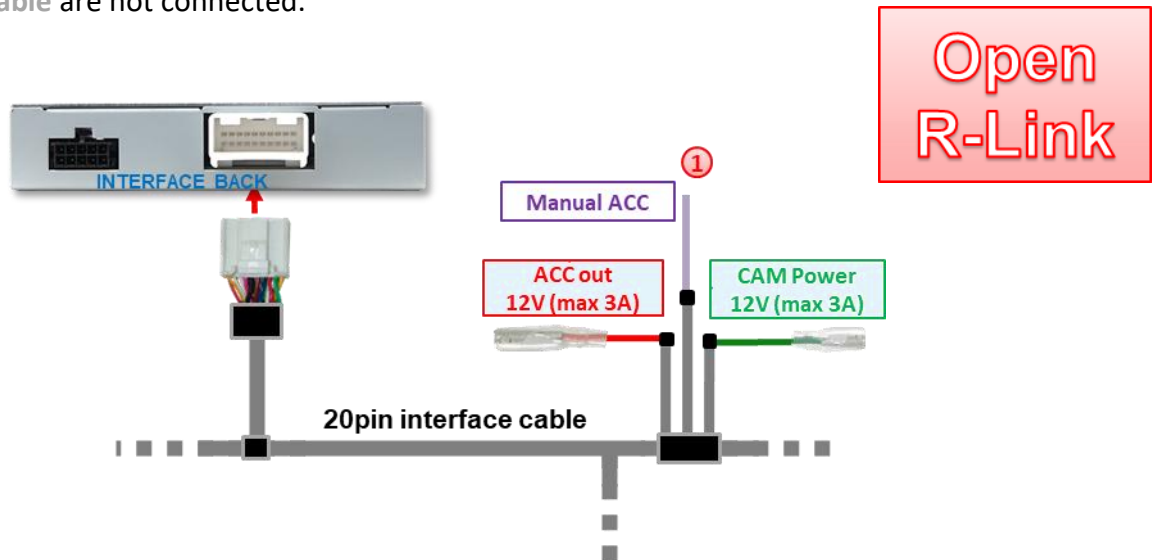

- 1 Connect the purple **Manual ACC** wire of the 20pin interface cable to **the +12V S contact (terminal 86s) or ACC terminal 15r** (e.g. cigarette lighter, glove compartment light).



Notes

- The screen is only switched on as long as the video interface is switched on via +12V to **Manual ACC**. Otherwise, the factory picture is also black. When selecting the switch-on signal, check whether the factory picture is available in all desired operating states.
- The display of driving lines is not available with an analogue connection.
- If the interface is connected via analogue (without CAN bus), the rear-view camera and side cameras must also be connected via analogue. See points:
 - 2.6.2Case 2: Reverse gear signal from analogue signal
 - 2.8.2Case 2: turn signals from analogue signal

2.5 Power supply outputs

The two **red** and **green** power supply lines **ACC out 12V (max 3A)** and **CAM Power 12V (max 3A)** of the 20pin interface cable can either be used as ACC power supply for the **V1-Left, V2-Right, V3-Front or HDMI input*** connected **external video sources** (e.g. iOS/Android devices, laptop, streaming stick, DVB-T2 tuner), or as a power supply for the **V1-Left, V2-Right, V3-Front, V4-Reverse or HDMI input*** (e.g. side, front and rear-view camera).

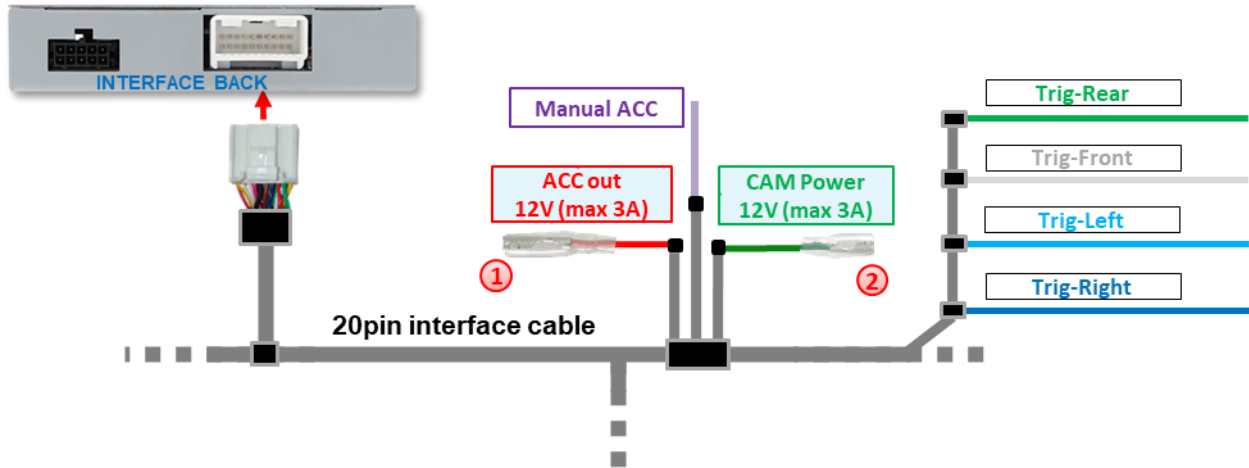

- 1** **External video sources** (not cameras) can be powered via the red **ACC out 12V (max 3A)** power supply line of the 20pin interface cable. The wire carries a **continuous** +12V ACC switching output current while the interface is switched on (see the following chapters for connection diagrams).
- 2** **Aftermarket cameras** (e.g. rear, side and front cameras) can be powered via the green **CAM Power 12V (max. 3A)** power supply line of the 20pin interface cable. The wire carries **+12V switching output current** only as long as one of the camera inputs is displayed, regardless of whether the connection is made via the vehicle CAN bus or via one of the trigger lines (see the following chapters for connection diagrams).

* HDMI input only available with HDV- IVI16

2.5.1 Connection and power supply – video sources

Rear-view camera, front camera and 2 side cameras

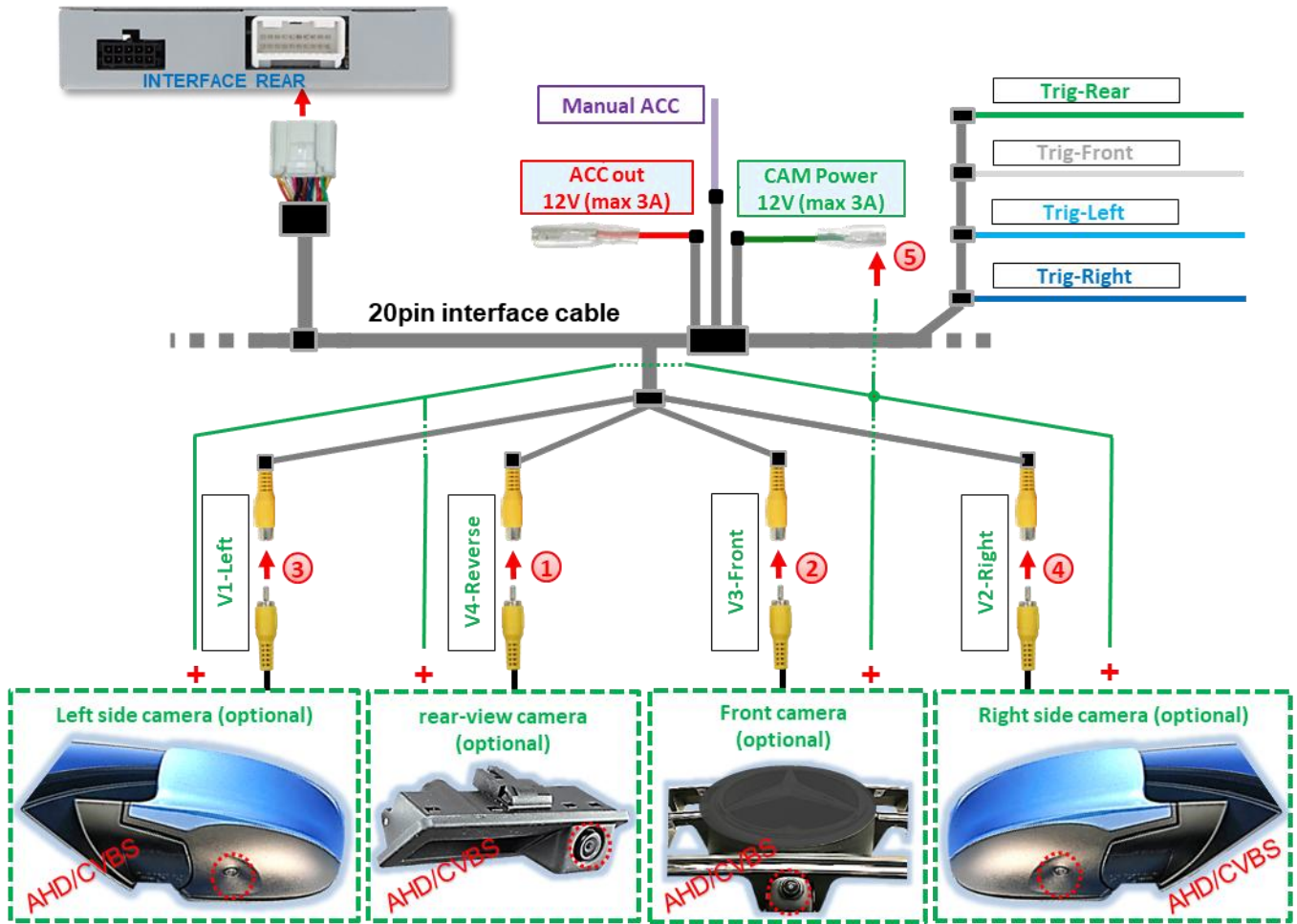

- ① Connect the RCA male connector of the rear-view camera to the RCA female connector **V4-Reverse** of the 20pin interface cable.
- ② Connect the RCA male connector of the front camera to the RCA female connector **V3-Front** of the 20pin interface cable.
- ③ Connect the RCA male connector of the left side camera to the RCA female connector **V1-Left** of the 20pin interface cable.
- ④ Connect the RCA male connector of the right side camera to the RCA female connector **V2-Right** of the 20pin interface cable.
- ⑤ Connect the power supply for all aftermarket cameras to **the green wire. CAM Power 12V (max 3A)** of the 20pin interface cable.



Note: The type of camera selection (via vehicle CAN bus or trigger lines) can be preset individually for each input in the OSD menu settings.

Attention!
The video signal type of each video source must be defined in the OSD menu of the corresponding video input.

2.5.2 Connection and power supply - Video sources rear-view camera, front camera and 2 video sources

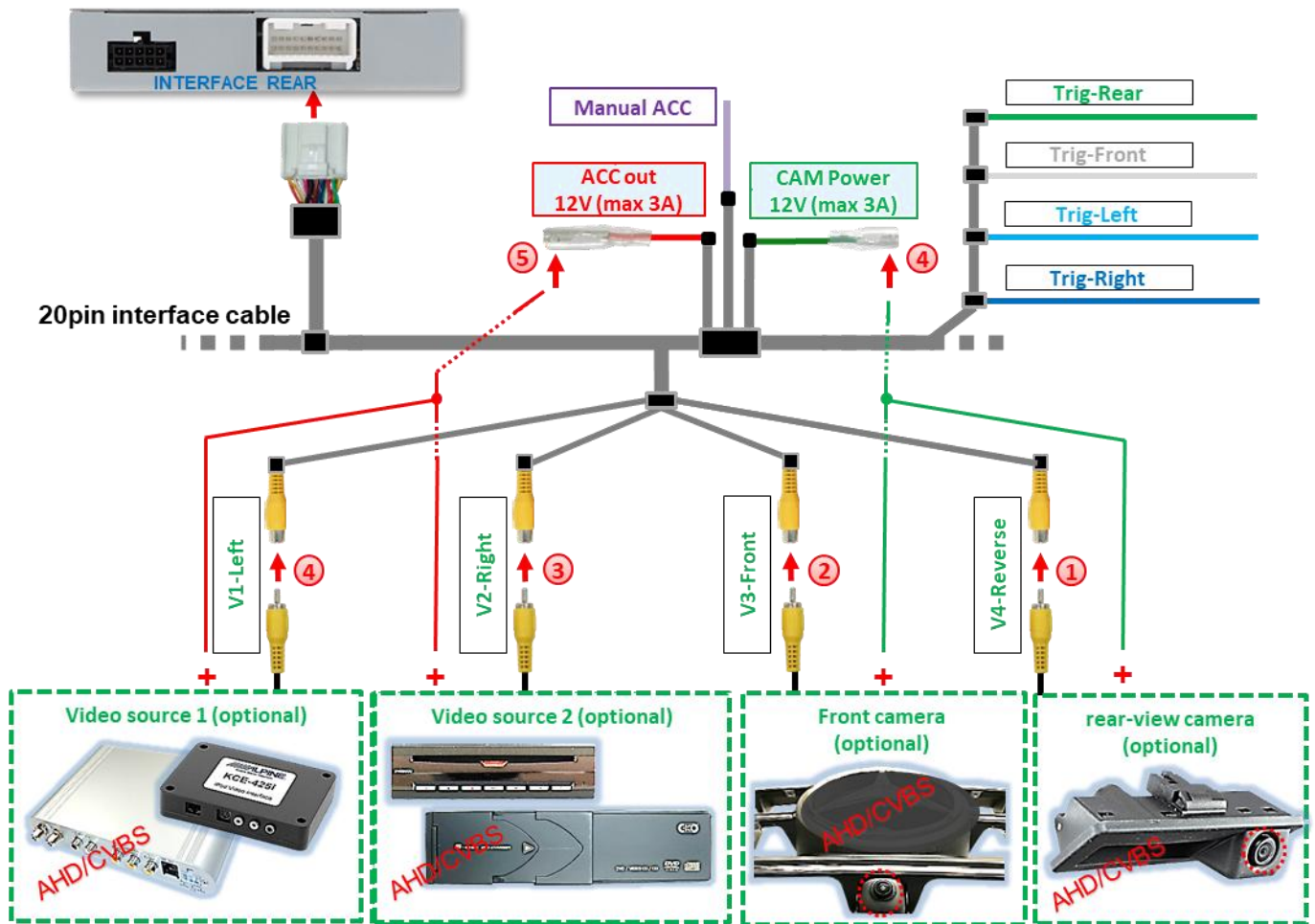

- ① Connect the RCA male connector of the rear-view camera to the RCA female connector **V4-Reverse** of the 20pin interface cable .
- ② Connect the RCA male connector of the front camera to the RCA female connector **V3-Front** of the 20pin interface cable.
- ③ Connect the RCA male connectors of video sources 1 and 2 to the RCA female connectors **V1-Left** and **V2-Right** of the 20pin interface cable.
- ④ Connect the power supply for aftermarket cameras to **the green wire of the CAM Power 12V (max 3A)** of the 20pin interface cable.
- ⑤ Connect the power supply for video sources to **the red wire ACC out 12V (max 3A)** of the 20pin interface cable.



Note: The type of camera selection (via vehicle CAN bus or trigger lines) can be preset individually for each input in the OSD menu settings.

Attention!
The video signal type of each video source must be defined in the OSD menu of the corresponding video input.

2.6 Aftermarket rear-view camera

Automatic switching to the rear-view camera can be done via the CAN bus or an analogue reverse gear signal.

2.6.1 Case 1: Reverse gear signal from CAN bus

The basic requirement is that the interface connection has been made with the CAN bus. Furthermore, the vehicle CAN bus reverse gear signal and detection by the interface must be compatible. The interface then supplies +12V on the **green wire CAM Power 12V (max 3A)** of the **20pin interface cable** while reverse gear is engaged, and the interface automatically switches to the rear-view camera input **V4-Reverse** or the **HDMI**- input*.
 See also chapter 1.4 Settings – 8 dip switch bench (interface functions) .

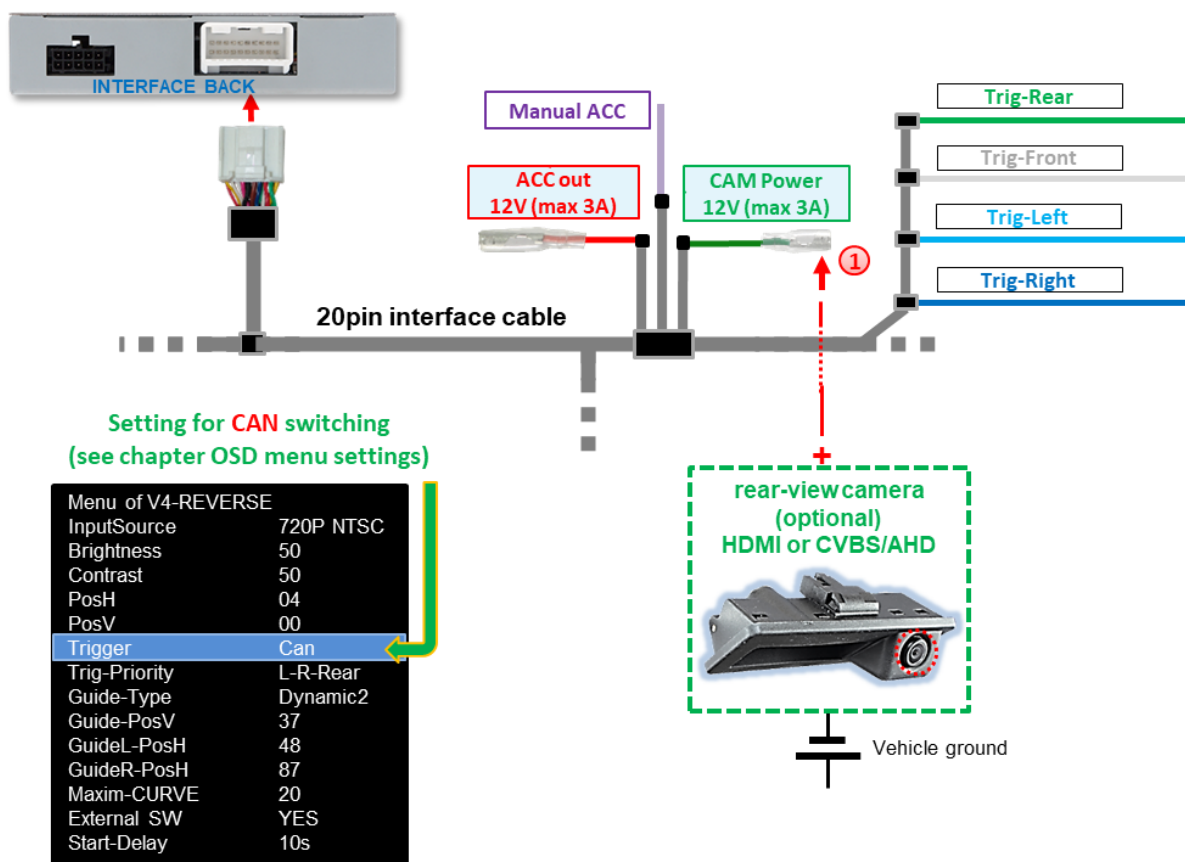

1 The +12V power supply for the aftermarket rear-view camera can be provided via the **green wire CAM Power 12V (max 3A)** of the **20pin interface cable**, as this wire only carries current when camera inputs are switched on (some cameras are not stable under continuous current).



Notes

- If the **HDMI** input* is defined as the rear-view camera input, the **V4 reverse** input will have no function!
- If the reverse gear detection of the interface on the CAN bus does not work , the reverse gear signal must be connected in an analogue manner.

* **HDMI input only available with HDV-IVI16**

2.6.2 Case 2: Reverse gear signal from analogue signal

If the interface is connected without a CAN bus or if the interface does not supply +12V to the **green CAM Power 12V (max 3A) wire** of the 20-pin interface cable while reverse gear is engaged (not all vehicles are compatible), an external switch signal from the reversing light is required. As the reversing signal contains electronic interference, a normally open relay (e.g. AC-MR-312 or AC-MR-201) or a noise filter (e.g. AC-PNF-RVC) is required. The following diagram shows the use of a normally open relay.

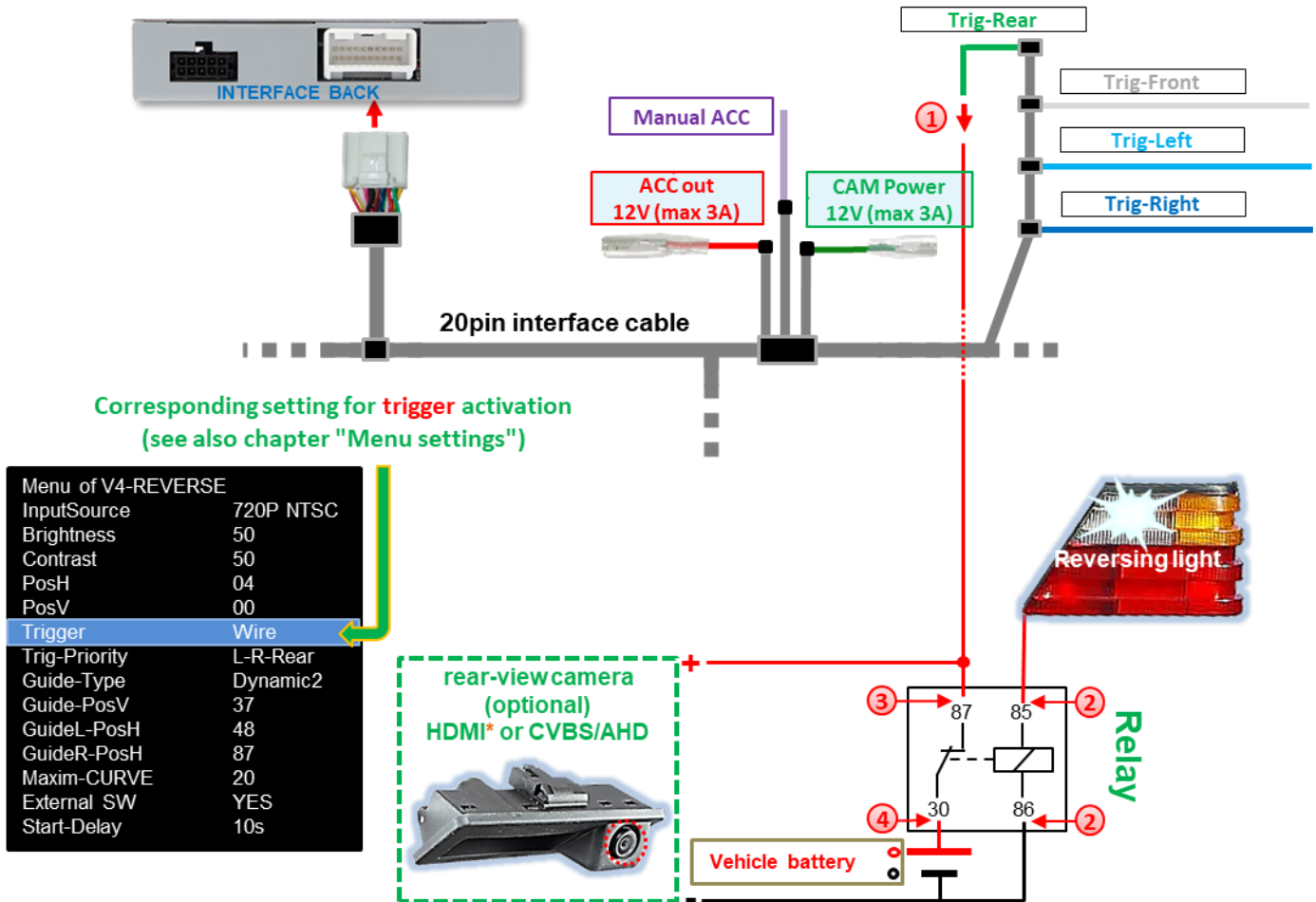

- ① Connect the **green wire Trig-REAR** to the output terminal (87) of the relay.
- ② Connect the reversing light power cable to the switching coil terminal (85) and the vehicle ground to the switching coil terminal (86) of the relay.
- ③ Connect the rear-view camera power supply wire to the output terminal (87) of the relay, in addition to the **green Trig-REAR wire**.
- ④ Connect the +12V continuous current to the input terminal (30) of the relay.



Note: For analogue connection, set the "Trigger" menu item in the OSD menu to "Wire"!

* HDMI input only available with HDV-IVI16

2.7 Aftermarket front camera

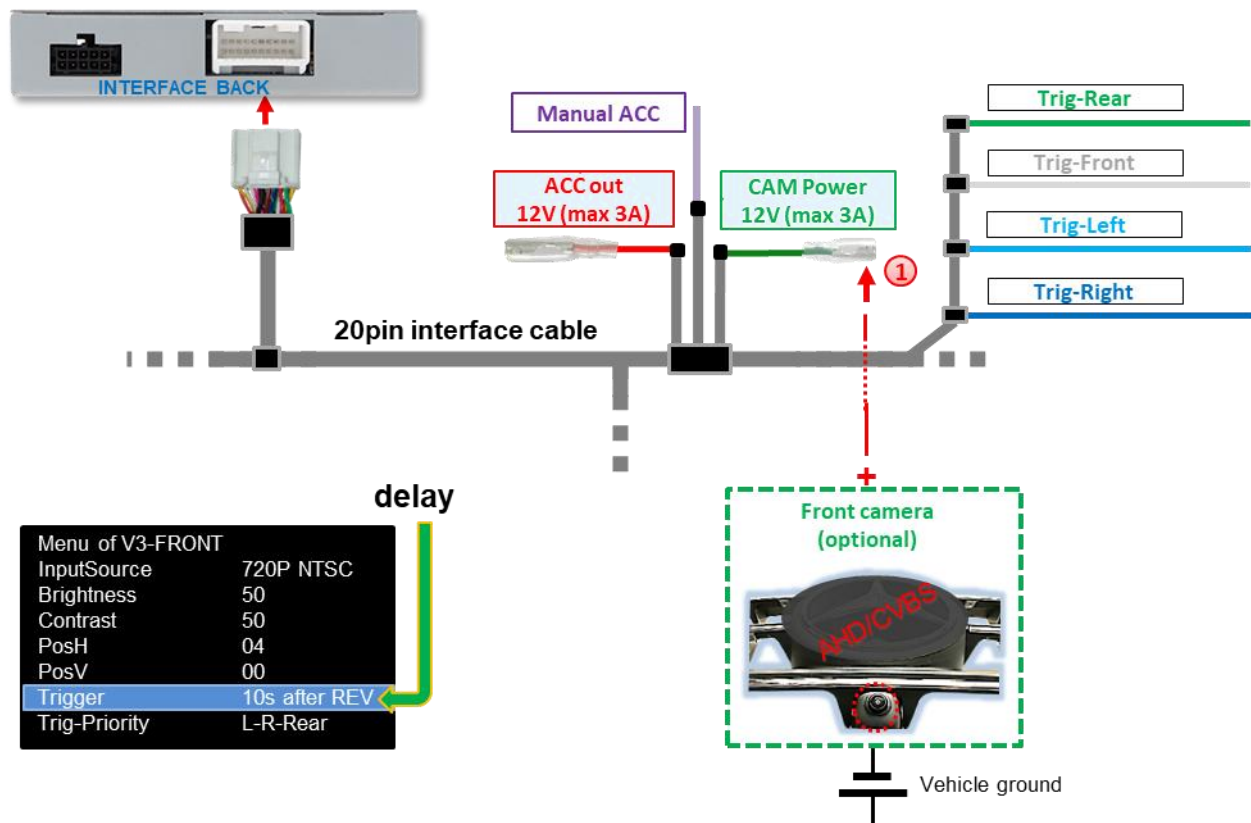

1 The **green wire CAM Power 12V (max. 3A)** can be used to power the front camera (and all other cameras connected to the video inputs). This only carries current for the duration of any camera activation (some cameras are not stable with continuous current). The prerequisite is that Dip 3 = **ON** (black 8 dip switch bench). The **green wire** then supplies +12V (max. 3A) as power for the front camera as long as the front camera input is displayed. The delay time can be individually selected for **5, 10, 15** or **20** seconds in the OSD menu settings of the front camera.

Switching to the front camera after reverse gear is engaged for the time set in the OSD menu occurs when a reverse gear signal is received from the CAN bus and with an analogue connection.



Note: In addition, manual switching to front camera input (short press) is possible from any picture mode using an external keypad (see chapter3 *Operating the video interface*).

2.8 Aftermarket side cameras

Side cameras can be connected via CAN bus or analogue selection.

2.8.1 Case 1: Turn signals from CAN bus

The basic requirement is that the interface connection has been made with CAN bus. Furthermore, vehicle CAN bus turn signals and their recognition by the interface must be compatible. Then, for the duration of a turn signal operations, +12V is applied to the **green CAM Power 12V (max 3A) wire** of the 20pin interface cable.

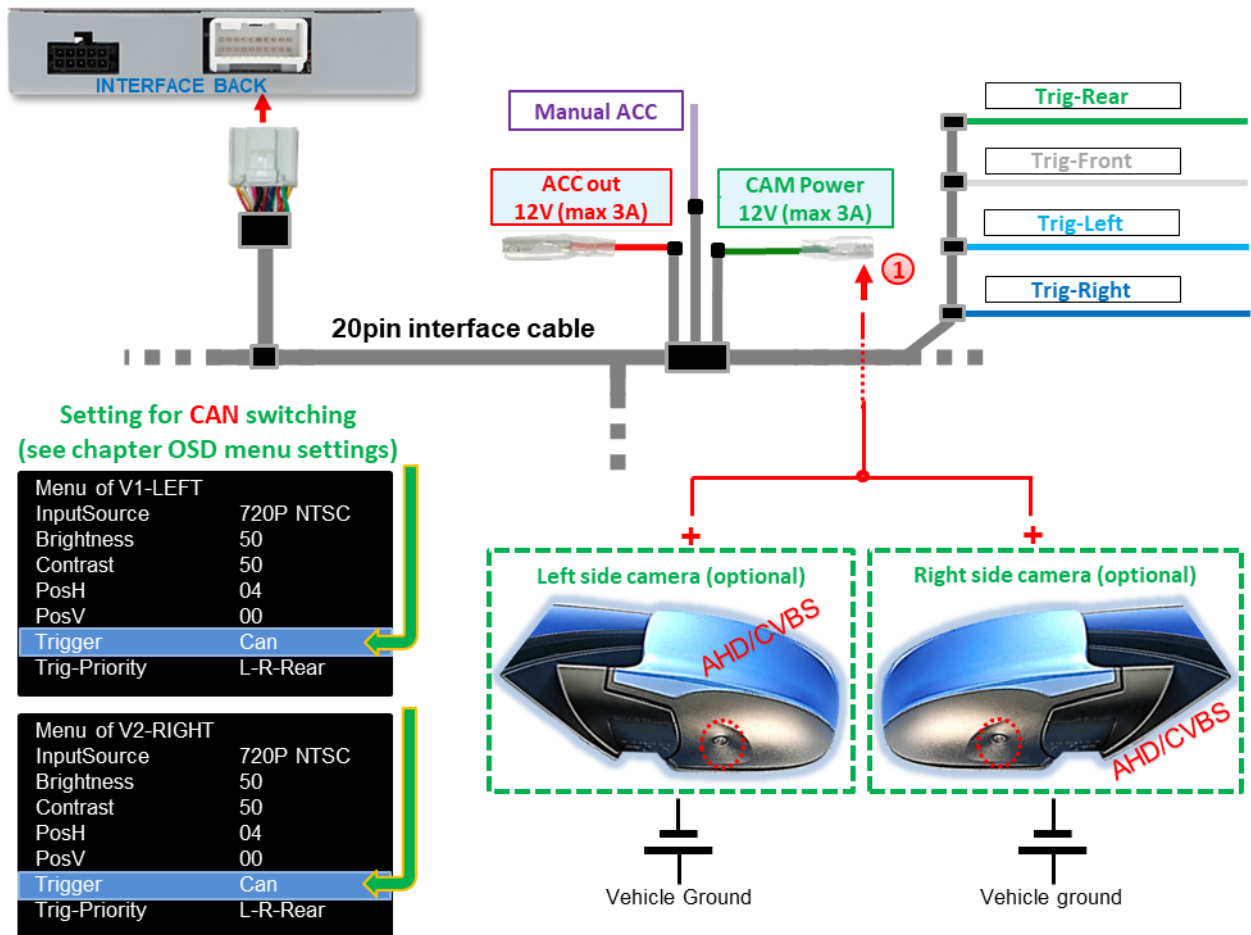

1 Power for the side cameras can be supplied via **the green CAM Power 12V wire (max 3A)** of the 20pin interface cable, as this wire only carries current when the camera is activated (some cameras are not stable under continuous current).



Note: If the interface's flashing signal detection on the vehicle CAN bus does not work, the turn signals must be connected in an analogue manner.

2.9 HDMI rear-view camera or other HDMI sources (HDV-IVI16 only)

HDMI input * The interface can generally be used for any video source with an HDMI output (e.g. rear-view camera, 360° camera system or other video sources such as smartphones, laptops, streaming sticks, DVB-T2 tuners, etc.).

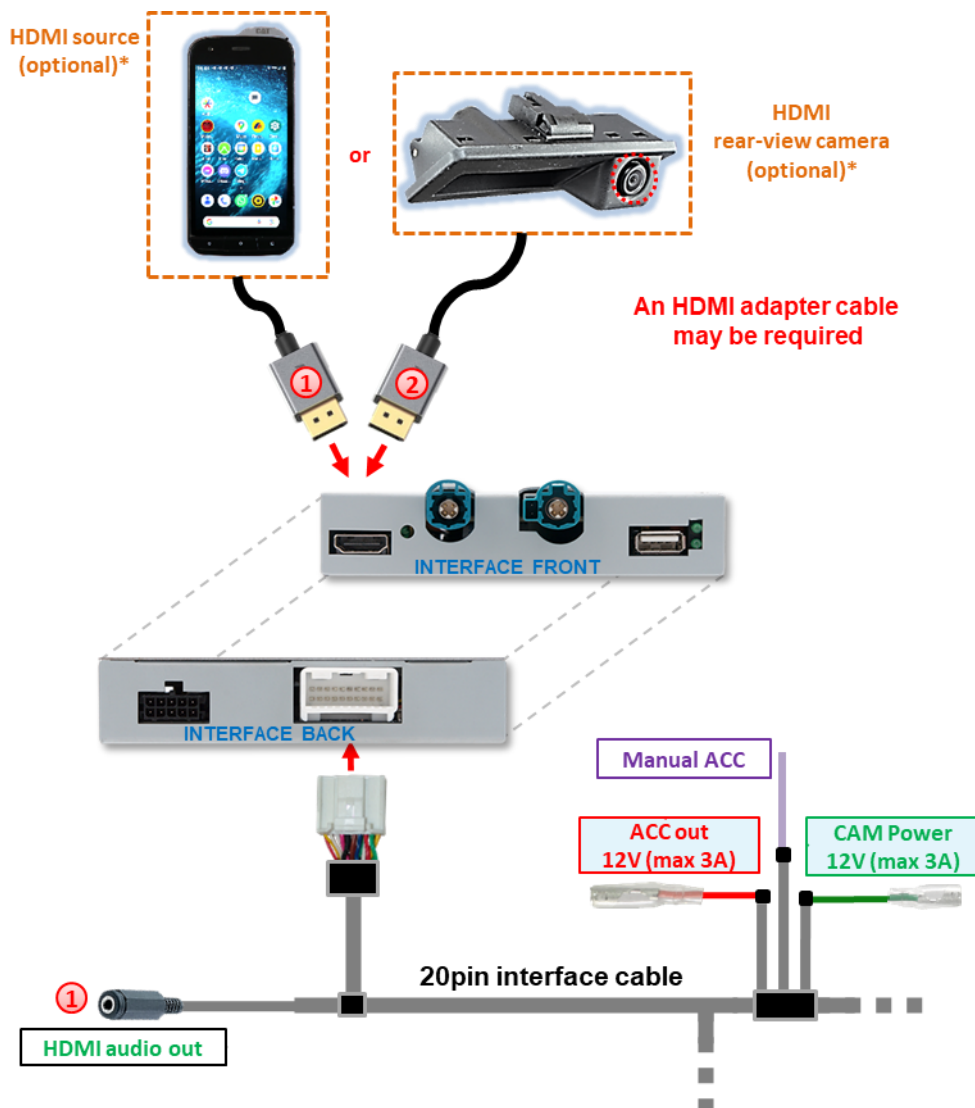

Picture settings in the HDMI menu

| Menu of HDMI | |
|--------------|------------|
| InputSource | AutoDetect |
| Brightness | 50 |
| Contrast | 50 |
| PosH | 04 |
| PosV | 00 |

Picture settings in the HDMI menu for rear-view camera

| Menu of HDMI-REVERSE | |
|----------------------|------------|
| InputSource | AutoDetect |
| Brightness | 50 |
| Contrast | 50 |
| PosH | 04 |
| PosV | 00 |
| Trigger | Can |
| Trig-Priority | L-R-Rear |
| Guide-Type | Dynamic2 |
| Guide-PosV | 37 |
| GuideL-PosH | 48 |
| GuideR-PosH | 87 |
| Maxim-CURVE | 20 |
| External SW | YES |
| Start-Delay | 10s |

- 1 If an optional HDMI video source is connected to the **HDMI input***, the picture displayed on the source's screen (e.g. smartphone, laptop, etc.) will be mirrored on the vehicle monitor. Other sources (e.g. streaming stick, DVD player, DVB-T tuner, etc.) can also be played back on the vehicle monitor. The video source can be powered via the **red wire ACC out 12V (max. 3A)** cable.

Received audio signals are output via the 3.5 mm jack socket **HDMI audio out*** of the **20pin interface cable**. (See the following chapter 2.10 Audio insertion .)

- 2 If a rear-view camera or a 360° camera system is connected to the **HDMI input*** (activated via CAN bus or analogue), the picture from the rear-view camera is displayed when reverse gear is engaged, and after disengagement, the picture from a front camera connected to the front camera input **V3-Front** is also displayed for the preset time. Power can be supplied via the **green wire CAM Power 12V (max 3A)** .

*** HDMI input only available with HDV-IVI16**

2.10 Audio insertion

The interface can only insert video signals into the factory infotainment system. For all connected AV sources, their audio output must be connected to the factory AUX input (if available) or an optional audio feeder (e.g. FM modulator).

Audio signals from **the HDMI input*** are output via the 3.5 mm jack socket **HDMI audio out** on the interface. In this case, the **HDMI audio out** of the interface must be connected to the factory AUX input (if available) or an optional audio feeder (e.g. FM modulator).

If several AV sources are connected to the infotainment system, an additional audio switch may be necessary. Input video signals can be activated in parallel with any audio mode of the factory infotainment system.

*** HDMI input only available with HDV-IVI16**

2.11 Connection - Video interface and external keypad

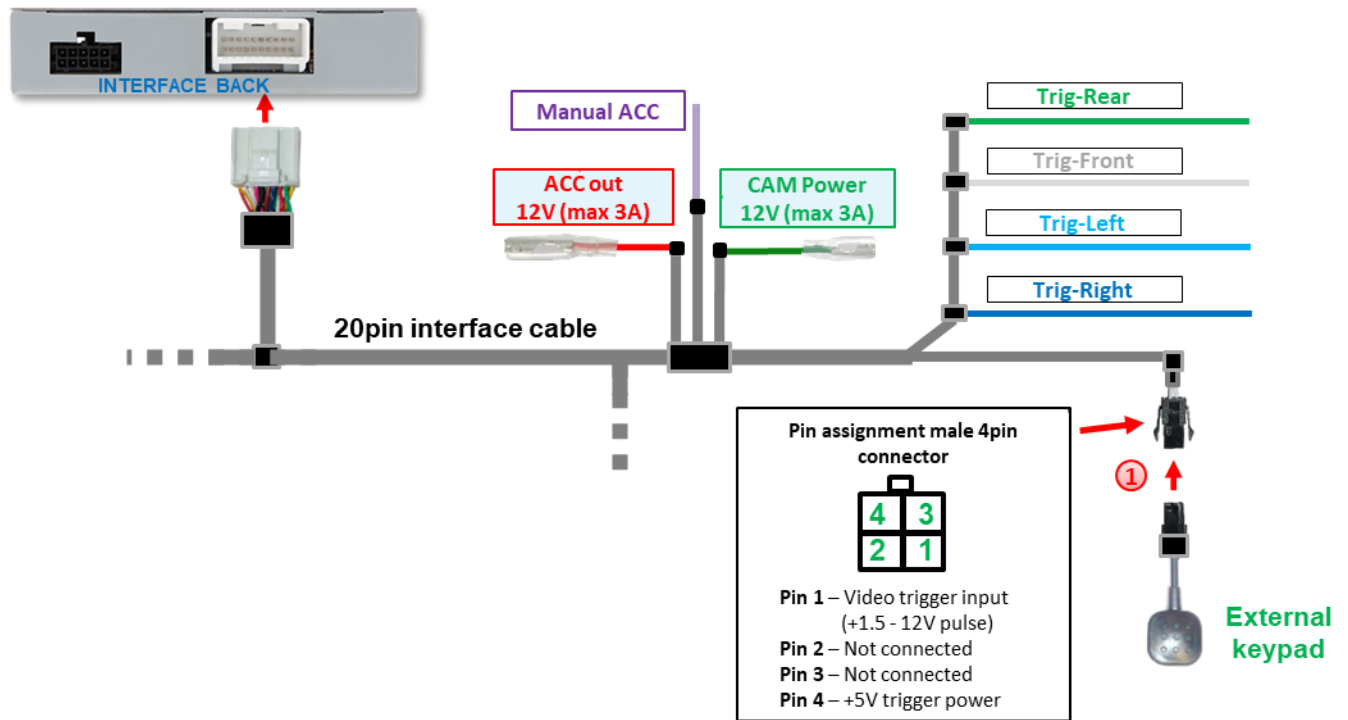

1 Connect the 4pin female connector of the external keypad to the 4pin male connector of the 20pin interface cable.



Note: Even if the keypad is not required for switching between multiple sources, it is strongly recommended that the keypad be connected and remain hidden on the interface. The keypad should not be installed in a "pressed" position.

Optional: Instead of the external keypad, the interface can also be operated using the optionally available "HDA-RC" remote control.* This allows direct selection of the video/camera inputs and more convenient changing of the settings in the respective OSD menus.

* The remote control is compatible with all HDA and HDV interfaces that are marked with 'RC' at the end of the software version.



"HDA-RC" remote control optionally available

2.12 settings OSD menu

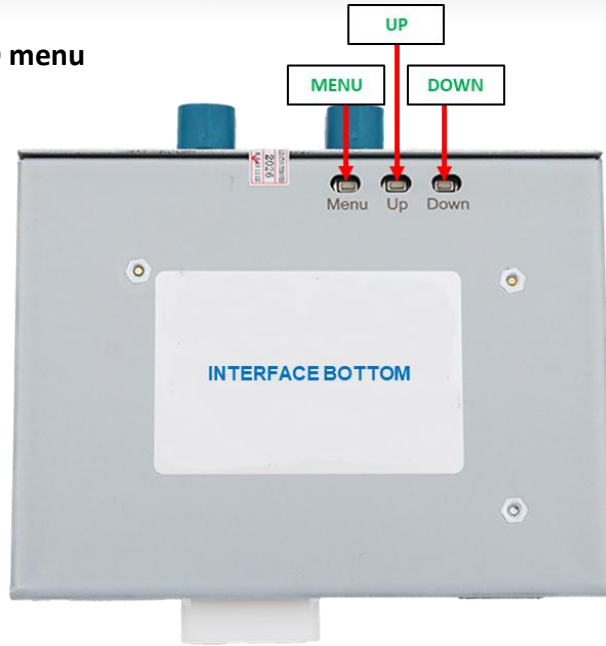

Attention!
The video signal type for each video source must be defined in the OSD menu for the corresponding video input.

OSD menu settings can be changed using the 3 keys on the rear of the interface. MENU opens the OSD settings menu or moves the cursor to the next menu item. UP and DOWN change the values of the current menu item.



The individual OSD settings menu for each video input can only be accessed while it is displayed, regardless of whether a video source is connected.

The following settings are available in the OSD settings menus of the 5 video inputs:

Menu **V1-Left (V2-Right)** 8pin DIP switch bank DIP 1 (DIP 2) = ON

- Input Source** Video input signal type for video source connected to **V1-Left (V2-Right)**. This **must** be defined for correct image reproduction. The following video source signal types can be selected:
CVBS video sources: **NTSC, PAL**
AHD video sources: **720p NTSC, 960p NTSC, 1080p NTSC, 720p PAL, 960p PAL, 1080p PAL**
- Brightness** Brightness
- Contrast** Contrast
- Pos. H** Horizontal image position
- Pos. V** Vertical image position
- Trigger** Type of video input selection **V1-Left (V2-Right)**

| Menu of V1-LEFT | |
|-----------------|-----------|
| InputSource | 720P NTSC |
| Brightness | 50 |
| Contrast | 50 |
| PosH | 04 |
| PosV | 00 |
| Trigger | Can |
| Trig-Priority | L-R-Rear |

| Menu of V2-RIGHT | |
|------------------|-----------|
| InputSource | 720P NTSC |
| Brightness | 50 |
| Contrast | 50 |
| PosH | 04 |
| PosV | 00 |
| Trigger | Can |
| Trig-Priority | L-R-Rear |

- Trigger** "CAN" function for side cameras via CAN bus. Selection of video input **V1-Left (V2-Right)** when the left (right) turn signal is activated. This requires that the turn signal is recognised by the interface on the vehicle CAN bus. Manual selection of this input via an external keypad does not work with this setting.
"Wire" function for other video sources or side cameras without CAN bus. Selection of video input **V1-Left (V2-Right)** is only possible via the **light blue (dark blue) Trig-Left (Trig-Right)** wire or manually via an external keypad.
- Trig priority** Priority of switching when switch signals are present for several inputs at the same time (CAN bus or analogue +12 V trigger). The signal with the highest priority is displayed:
L-R-Rear: V1-Left → V2-Right → V4-Reverse
Rear-R-L: V4-Reverse → V2-Right → V1-Left

Menu V3-Front

8 dip switch bench Dip 3 = ON

Input Source Video input signal type for video source connected to **V3 front**. This **must** be defined for correct image reproduction. The following video source signal types can be selected:

CVBS video sources: **NTSC, PAL**
 AHD video sources: **720p NTSC, 960p NTSC, 1080p NTSC, 720p PAL, 960p PAL, 1080p PAL**

Brightness Brightness
Contrast Contrast
Pos. H Horizontal image position
Pos. V Vertical image position
Trigger Type of selection for video input **V3 front**.

Delay function for front camera. The delay setting determines the automatic switching of a front camera connected to the V3 front input after reverse gear is engaged, as well as its display duration on the screen. Available are 5s after REV, 10s after REV, 15s after REV, 20s after REV.

"Wire" function for other video sources. If another video source is to be connected to **V3-Front** instead of a front camera, select the "Wire" setting. This deactivates the "Delay" function and the input can only be selected via the **white Trig-Front** wire or manually via an external keypad.

Trig priority Priority of switching when switch signals are present for several inputs at the same time (CAN bus or analogue +12 V trigger). The signal with the highest priority is displayed:
L-R-Rear: V1-Left → V2-Right → V4-Reverse
Rear-R-L: V4-Reverse → V2-Right → V1-Left

| Menu of V3-FRONT | |
|------------------|---------------|
| InputSource | 720P NTSC |
| Brightness | 50 |
| Contrast | 50 |
| PosH | 04 |
| PosV | 00 |
| Trigger | 10s after REV |
| Trig-Priority | L-R-Rear |

V4-Reverse menu 8 dip switch bench Dip 4 = ON, Dip 5 = OFF, Dip 6 = OFF

V4-Reverse input has no function if **HDMI** input* is defined as tear-view camera input (Dip 5 = ON).

- Input Source** Video input signal type for video source connected to **V4 Reverse**. This **must** be defined for correct image reproduction . The following video source signal types can be used :
CVBS video sources: **NTSC, PAL**
AHD video sources: **720p NTSC, 960p NTSC, 1080p NTSC, 720p PAL, 960p PAL, 1080p PAL**
- Brightness** Brightness
- Contrast** Contrast
- Pos. H** Horizontal image position
- Pos. V** Vertical image position
- Trigger** Type of selection for rear-view camera input **V4 reverse**.
"CAN" function with CAN bus connection. With the "CAN" setting, the system automatically switches to **V4 Reverse** for CVBS/AHD rear-view camera when reverse gear is engaged. This requires the interface to recognise reverse gear in the CAN bus.
"Wire" function with analogue connection. A rear-view camera connected to **the V4 Reverse** can be selected via the **green Trig Left wire** using either the "Wire" or "CAN" setting. We recommend setting "Wire" for analogue (reversing signal) connections.
- Trig priority** Priority of switching when switch signals are present for several inputs at the same time (CAN bus or analogue +12 V trigger). The signal with the highest priority is displayed:
L-R-Rear: V1-Left → V2-Right → V4-Reverse
Rear-R-L: V4-Reverse → V2-Right → V1-Left
- Guide Type** Setting of 6 different angles for the guide lines for the rear-view camera
Movable guide lines **Dynamic 1-6**
Fixed guide lines **Fixed 1-6**
No guide lines **OFF**
- Guide pos. V** Vertical position of the guide lines **00-69**
- Guide L Pos.H** Horizontal position of the left guide line **00-90**
- Guide R Pos.H** Horizontal position of the right guide line **00-121**
- Maximum CURVE** Radius of the guide lines **01-20**
- External SW** Selectable via external keypad **V4 Reverse**
YES: Factory video → HDMI* → V1-Left → V2-Right → V4-Reverse → Factory video
NO: Factory video → HDMI* → V1-Left → V2-Right → Factory video
- Start delay** Switchover delay of the interface at start-up. This function is technically necessary in some vehicles, as otherwise malfunctions of the factory system may occur (e.g. black screen, touch problems). The following options are available (in seconds):
5s/6s/7s/8s/9s/10s/12s/15s/20s
Changing the default settings may lead to malfunctions!

| Menu of V4-REVERSE | |
|--------------------|-----------|
| InputSource | 720P NTSC |
| Brightness | 50 |
| Contrast | 50 |
| PosH | 04 |
| PosV | 00 |
| Trigger | Can |
| Trig-Priority | L-R-Rear |
| Guide-Type | Dynamic2 |
| Guide-PosV | 37 |
| GuideL-PosH | 48 |
| GuideR-PosH | 87 |
| Maxim-CURVE | 20 |
| External SW | YES |
| Start-Delay | 10s |

* **HDMI input only available with HDV-IVI16**

HDMI menu*

8 dip switch bench (DIP 4 = ON, DIP 5 = **ON/OFF**, DIP 6 = ON)

HDMI AV input (Dip 5 = OFF)

| | |
|--------------------|---|
| InputSource | The picture resolution of connected HDMI sources is automatically detected. |
| Brightness | Brightness |
| Contrast | Contrast |
| Pos. H | Horizontal image position |
| Pos. V | Vertical image position |

| Menu of HDMI | |
|--------------|------------|
| InputSource | AutoDetect |
| Brightness | 50 |
| Contrast | 50 |
| PosH | 04 |
| PosV | 00 |

HDMI rear-view camera input (Dip 5 = ON)

| | |
|--------------------|---|
| InputSource | The picture resolution of connected HDMI sources is automatically detected. |
| Brightness | Brightness |
| Contrast | Contrast |
| Pos. H | Horizontal image position |
| Pos. V | Vertical image position |
| Trigger | Type of selection for rear-view camera input HDMI-REV . |

| Menu of HDMI-REVERSE | |
|----------------------|------------|
| InputSource | AutoDetect |
| Brightness | 50 |
| Contrast | 50 |
| PosH | 04 |
| PosV | 00 |
| Trigger | Can |
| Trig-Priority | L-R-Rear |
| Guide-Type | Dynamic2 |
| Guide-PosV | 37 |
| GuideL-PosH | 48 |
| GuideR-PosH | 87 |
| Maxim-CURVE | 20 |
| External SW | YES |
| Start-Delay | 10s |

"CAN" function with CAN bus connection. With the "CAN" setting, the system automatically switches to **HDMI*** for the HDMI rear-view camera when reverse gear is engaged. This requires the interface to recognise reverse gear in the CAN bus.

"Wire" function with analogue connection. A rear-view camera connected to **HDMI*** can be selected via the **green Trig Rear wire** using either the "Wire" or "CAN" setting. We recommend setting "Wire" for analogue (reversing signal) connections.

Trig priority Priority of switching when switch signals are present for several inputs at the same time (CAN bus or analogue +12 V trigger). The signal with the highest priority is displayed:

L-R-Rear: V1-Left → V2-Right → V4-Reverse

Rear-R-L: V4-Reverse → V2-Right → V1-Left

Guide Type Setting of 6 different angles for the guide lines for the rear-view camera

| | |
|---------------------|--------------------|
| Movable guide lines | Dynamic 1-6 |
| Fixed guide lines | Fixed 1-6 |
| No guide lines | OFF |

Guide pos. V Vertical position of guide lines **00-69**

Guide L Pos.H Horizontal position of the left guide line **00-90**

Guide R Pos.H Horizontal position of the right guide line **00-121**

Maximum curve Radius of the guide lines **01-20**

External SW Selectable via external keypad **V4 Reverse**
YES: Factory video → **HDMI*** → **V1-Left** → **V2-Right** → **V4-Reverse** → Factory video
NO: Factory video → **HDMI*** → **V1-Left** → **V2-Right** → Factory video

Start delay Switching delay of the interface at start-up. This function is technically necessary in some vehicles, as otherwise malfunctions of the factory system may occur (e.g. black screen, touch problems). The following options are available (in seconds):

5s/6s/7s/8s/9s/10s/12s/15s/20s

Changing the default settings may lead to malfunctions!



Notes: **V4 reverse** input is no function when the **HDMI input*** is defined as the rear-view camera input (Dip 5 = **ON**).

* **HDMI input only available with HDV-IVI16**

3 Operating the video interface

The external keypad can be used to switch between all activated inputs.

➤ Long press of the keypad (2-3 seconds)

When pressed and held (2-3 seconds), the external keypad switches from the factory video to the first activated interface video input. Each additional long press switches to the next activated interface video input until the last one is reached, at which point it switches back to the factory video. Deactivated inputs are skipped. If all inputs are activated via the corresponding dip switch, the order is as follows:

Factory video → HDMI → V1-Left → V2-Right → V4-Reverse** → Factory video*

* **HDMI input only available with HDV-IVI16**

****V4-Reverse** can only be selected via the external keypad if the "External SW" function is set to "Yes" in the **V4-Reverse** menu

➤ Short press of the keypad (only possible if Dip 3 is set to ON)

When pressed briefly, the external keypad switches from the current video mode to the front camera input.

input **V3-Front** and returns to the previous video mode when pressed again briefly .



Note: Even if the keypad is not needed to switch between multiple sources, it is strongly recommended that the keypad be connected and remain hidden on the interface. The keypad should then not be installed in a "pressed" position.

3.1 Optional: Operating the video interface via the "HDA-RC" remote control

Instead of the external keypad, the interface can also be operated via the optionally available "HDA-RC" remote control.* This allows direct selection of the video/camera inputs and more convenient changing of the settings in the respective OSD menus.

* The remote control is compatible with all HDA and HDV interfaces that are marked with 'RC' at the end of the software version.



"HDA-RC" remote control
optionally available

4 Specifications

| | |
|---------------------------|---|
| BATT/ACC range | 9V - 16V |
| Stand-by power drain | approx. 1mA |
| Power consumption | approx. 350mA @12V |
| Video input | 0.7V - 1V |
| Video input signal types | FBAS/AHD/HDMI (HDV version only) |
| Signal standards CVBS/AHD | NTSC/PAL |
| Temperature range | -40°C to +85°C |
| Video box dimensions | 117 x 25 x 110 mm (W x H x D) |

5 FAQ – Troubleshooting Interface functions – product-specific

| Problem | Possible cause | Solution |
|----------------------------|---|--|
| Vehicle battery discharges | Power connection made to battery terminal 30 | See chapter 2.4.1.2 <i>Open R-Link with vertical 10.4inch monitor – cable sets, power supply and CAN bus or analogue without CAN bus</i> – connection of the 10pin power/CAN cable |
| Malfunction or no picture | Video input signal type for video source not defined in the OSD of the respective video input | See chapter 2.12 <i>settings OSD menu</i> - menu of the respective input |

6 FAQ - Troubleshooting Interface functions - general

For any troubles which may occur, check the following table for a solution before requesting support from your vendor.

| Symptom | Possible reason | Possible solution |
|--|---|--|
| No picture/black picture (factory picture). | Not all connectors have been reconnected to factory head-unit or monitor after installation. | Connect missing connectors. |
| | CAN-bus wires connected to CAN-bus in wrong place. | Refer to the manual where to connect to the CAN-bus. If not mentioned, try another place to connect to the CAN-bus. |
| | No power on video-interface (all LED video-interface are off). | Check power connection of interface. |
| No picture/black picture/white picture (inserted picture) but factory picture is OK. | No picture from video source. | Check on other monitor whether video source is OK. |
| | No video-source connected to the selected interface input. | Check settings dips 1 to 5 of 8dip bench of video interface which inputs are enabled and switch to corresponding input(s). |
| | Setting of video signal type of active video input is not equal to video signal type of connected video-source. | Set the video signal type of the video source correctly in the OSD menu of the corresponding input. |
| | LVDS cables plugged in wrong place. | Double-check whether order of LVDS cables is exactly connected according to manual. Plugging into head-unit does not work when the manual says to plug into monitor and vice versa. |
| | Wrong settings of video-interface. | Verify the vehicle-specific dip switch position in the instructions. If necessary, test different positions of the vehicle-specific dip switches. Perform a power reset after each change (briefly remove the black 10-pin micro-fit power socket once). |
| Inserted picture totally wrong size or position. | Wrong settings of video-interface. | Verify the vehicle-specific dip switch position in the instructions. If necessary, test different positions of the vehicle-specific dip switches. Perform a power reset after each change (briefly remove the black 10-pin micro-fit power socket once). |
| Inserted picture double or multiple times on monitor. | | |
| Inserted picture distorted, flickering or running vertically. | Video sources output set to AUTO or MULTI which causes a conflict with the interfaces auto detection. | (Only concerns video-sources with selectable output – e.g., DVD-Players, TV-Tuners, etc.) Set video source output fixed to PAL or NTSC. It is best to set all video sources to the same video signal type output. |
| | If error occurs only after source switching: Connected sources are not set to same video signal type output. | Set all video sources to the same video signal type output. |
| | Setting of video signal type of active video input is not equal to video signal type of connected video-source. | Set the video signal type of the video source correctly in the OSD menu of the corresponding input. |
| Inserted picture b/w. | Setting of video signal type of active video input is not equal to video signal type of connected video-source. | Set the video signal type of the video source correctly in the OSD menu of the corresponding input. |

| Symptom | Possible reason | Possible solution |
|---|--|--|
| Only on first inserted video activation after IGN on, the inserted picture is distorted. | Menu item <i>Trigger</i> of the corresponding video-input is set to <i>CAN-bus</i> though analogue signal triggering is used. | Open OSD-menu of corresponding video input and set the menu item <i>Trigger</i> to <i>Wire</i> . |
| Inserted picture qual. bad. | Picture settings have not been adjusted. | Use the 3 switches on interface-box or optional HDA-RC cable remote control to set the desired picture settings for the respective video source in the OSD menu of the interface. |
| Inserted picture size slightly wrong. | | |
| Inserted picture position wrong. | | |
| Camera input picture flickers. | Camera is being tested under fluorescent light (neon). | Test camera under natural light outside the garage. |
| Camera input picture is bluish. | Protection sticker not removed from camera lens. | Remove protection sticker from lens. |
| Camera input picture black. | Camera power taken directly from reverse gear lamp. | Use relay or electronic filter to "clean" reverse gear lamp power. Alternatively, camera power can be taken from green wire CAM Power. |
| Camera input picture has distortion. | | |
| Switching to inserted video does not work after IGN on or vehicle startup- temporary. | Interface has a start-up delay during which, after interface start-up for certain time, there is no switching to inserted video. Required to prevent the factory system from crashing. | In OSD menu of V4, default delay can be shortened time in menu item <i>StartDelay</i> , this might especially make sense on installations without connection to CAN-bus. Note: Too short <i>StartDelay</i> setting can cause (sporadically) black-screen of factory picture or loss of factory touch-screen control. |
| Not possible to switch video sources by OEM button. | Function not supported in this vehicle. | Use external keypad for AV-switching. |
| Not possible to switch video sources by external keypad. | Pressed too short. | For video source switching a longer press of about 2.5 seconds is required. |
| | Video-input is not enabled. | Enable corresponding inputs (dips 1 to 5 of 8dip bench). |
| Interface does not switch to reverse camera input when reverse gear is engaged or does not switch to side camera input(s) when turn signal in on. | CAN-bus of vehicle not fully compatible with interface. Function not supported. | Follow the manual for R-gear signal or turn signal from analogue signal. |
| | Menu item <i>trigger</i> in the OSD of the video-input was set to <i>Wire</i> . | Switch on corresponding input by external button or 12V to corresponding trigger input. Open OSD-menu of corresponding video input and set the menu item <i>Trigger</i> to <i>CAN bus</i> . |
| OSD-menu of interface cannot be accessed/opened. | No inserted video input of interface is active, factory picture is displayed. | Each video input of interface has its own OSD with its own settings. The OSD for each input can only be opened when the input is displayed. |

7 Technical Support

Please note that direct technical support is only available for products purchased directly from NavLinkz GmbH. For products bought from other sources, contact your vendor for technical support.

For any support requests make sure to at least prepare:

- Product code and serial number of all involved products
- Vehicle data such brand, model, year of production, VIN, infotainment model

NavLinkz GmbH
Distribution/Tech dealer-support
Heidberghof 2
D-47495 Rheinberg

Tel +49 2843 17595 00

Email mail@navlinkz.de



10R-06 5485



Made in China

