

## Video inserters HDV-MBN55

Compatible with **Mercedes Benz** vehicles with  
Comand Online NTG5.5 with 10.25inch or 12inch monitor  
and Audio 20 NTG5.5 with 8inch monitor  
with double Fakra connector at the head-unit



example

**Attention!**  
Video signal type of each video  
source must be preset in OSD-menu  
of corresponding video-input.

### Product features

- 1 x CVBS/AHD-input for rear-view camera
- 1 x CVBS/AHD-input for front camera
- 2 x CVBS/AHD-input for side-cameras or additional after-market video-sources (e.g., USB-device, DVB-T2 Tuner, etc.)
- All inputs NTSC and PAL compatible  
Supported AHD resolutions 720p NTSC (30Hz), 720p PAL (25Hz), 960p NTSC (30Hz), 960p PAL (25Hz), 1080p NTSC (30Hz), 1080p PAL (25Hz)
- **HDV-MBN55 only:** 1 HDMI-input for HD rear-view camera or additional HDMI-sources (e.g., IOS/Android, laptop, streaming stick, DVD-Player, DVB-T2 Tuner, etc.)  
Supported HDMI resolutions 720p NTSC (60Hz), 720p PAL (50Hz), 1080p NTSC (60Hz), 1080p PAL (50Hz)
- **HDV-MBN55 only:** Analogue audio output for HDMI source
- Automatic switching to rear-view camera input while reverse gear is engaged
- Automatic front camera switching after reverse gear for 5, 10, 15 or 20 seconds
- Adjustable guide lines (fixed or movable) can be activated for rear-view camera (movable guide lines not available for all vehicles)
- Picture free during the car ride (only for inserted video-sources)

## Contents

<b>1</b>	<b>Prior to installation</b>	<b>3</b>
1.1	Delivery contents	3
1.2	Checking the compatibility of vehicle and accessories	4
1.3	Boxes and connectors - interface	5
1.4	Settings - 8dip switch bench (interface functions)	6
1.4.1	Video inputs V1-Left and V2-Right (dip 1-2)	6
1.4.2	Front camera input V3-Front (dip 3)	6
1.4.3	Rear-view camera settings (dip 4)	7
1.4.4	Rear-view cam connection type (dip 5)	7
1.4.5	HDMI-input* (dip 6)	7
1.4.6	Monitor selection (dip 7+8)	7
1.5	Settings - 6dip switch bench (monitor definition)	8
1.6	Settings - 4dip switch bench (CAN-bus)	8
<b>2</b>	<b>Installation</b>	<b>9</b>
2.1	Place of installation	9
2.2	Connection schema	10
2.3	Connection - picture signal cable	11
2.3.1	Standard connection - picture signal cable (oher coloured double Fakra)	11
2.3.2	Special case: Connection - picture signal cable (blue double Fakra)	12
2.4	Connection – harnesses, power supply and CAN-bus or analogue without CAN-bus	13
2.4.1	Connection with CAN-bus	14
2.4.2	<i>Analogue connection without CAN-bus</i>	15
2.5	Power supply outputs	16
2.5.1	Connection and power-supply - video-sources rear-view camera, front camera and 2 side-cameras	17
2.5.2	Connection and power-supply - video-sources rear-view camera, front camera and 2 video-sources	18
2.6	After-market rear-view camera	19
2.6.1	Case 1: Reverse signal by CAN-bus	19
2.6.2	Case 2: Reverse signal from analogue signal	20
2.7	After-market front camera	21
2.8	After-market side-cameras	22
2.8.1	Case 1: Turn signal from CAN-bus	22
2.8.2	Case 2: Turn signal from analogue signal	23
2.9	HDMI rear-view camera or other HDMI-source (only HDV-MBN55)	24
2.10	Audio-insertion	25
2.11	Connection - Interface and external keypad	25
2.12	OSD-menu settings	26
<b>3</b>	<b>Interface operation</b>	<b>30</b>
3.1	Optional: Operating the video interface via the 'HDA-RC' remote control	30
<b>4</b>	<b>Specifications</b>	<b>31</b>
<b>5</b>	<b>FAQ - Troubleshooting interface functions - product-specific</b>	<b>31</b>
<b>6</b>	<b>FAQ - Troubleshooting Interface functions - general</b>	Fehler! Textmarke nicht definiert.
<b>7</b>	<b>Technical Support</b>	Fehler! Textmarke nicht definiert.

## Legal Information

By law, watching moving pictures while driving is prohibited, the driver must not be distracted. We do not accept any liability for material damage or personal injury resulting, directly or indirectly, from installation or operation of this product. Apart from using this product in an unmoved vehicle, it should only be used to display fixed menus (for example the MP3 menu of USB devices) or (rear-view) cameras' video when the vehicle is moving.

Changes/updates of the vehicle's software can cause malfunctions of the interface. Up to one year after purchase we offer free software-updates for our interfaces. To receive a free update, the interface has to be sent in at own cost. Wages for de- and reinstallation or other expenditures involved with the software-updates will not be refunded.

## 1 Prior to installation

Read the manual prior to installation. Technical knowledge is necessary for installation. The video interface's place of installation must be free of moisture and away from heat sources.

**Before the final installation in the vehicle, we recommend a test-run to ensure the compatibility of vehicle and interface. Due to changes in the production of the vehicle manufacturer there's always a possibility of incompatibility.**

### 1.1 Delivery contents

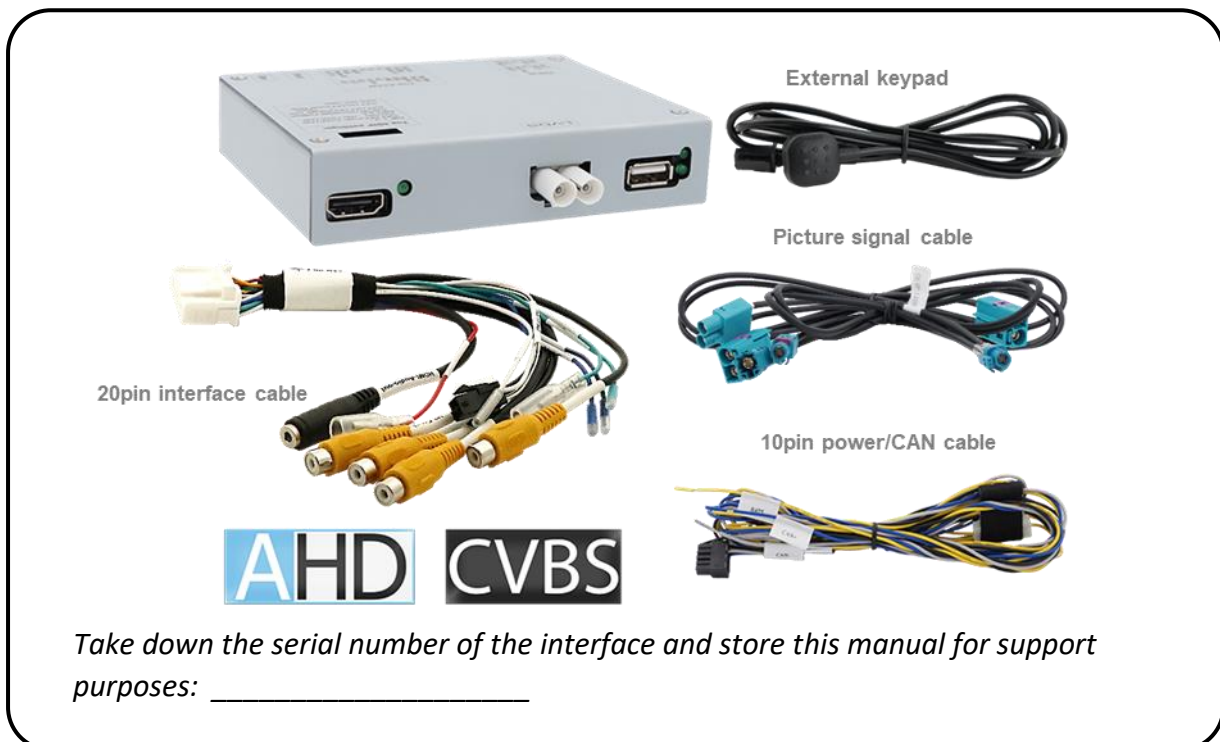

## 1.2 Checking the compatibility of vehicle and accessories

### Requirements

Brand	Compatible vehicles	Compatible systems
<b>Mercedes Benz</b>	C-Class (W205) 08/2018-11/2020, C-Class T-Model (S205) 08/2018-02/2021, C-Class Convertible (A205) 08/2018-03/2023, C-Class Coupe (C205) 08/2018-03/2023, CLS Coupe (C257) 02/2018-07/2020, E-Class (W213) 04/2016-06/2020, E-Class T-Model (S213) 04/2016-06/2020, E-Class Convertible (A238) 09/2017-06/2020, E-Class Coupe (C238) 09/2017-06/2020, G-Class (G463) 05/2018- GT AMG 4door (X290) 09/2018-06/2020, S-Class Coupe (C217) ca. 05/2017-08/2020, S-Class (V222/X222/W222) 05/2017-11/2020	<b>Comand Online NTG 5.5</b> with 10.25inch or 12inch monitor <b>Audio 20 NTG 5.5</b> with 8inch monitor  <i>For vehicles without factory TV tuner only!</i>

### Limitations

#### *CAN-bus compatibility*

CAN-bus compatibility of interface may to some vehicles have no or limited compatibility. This can show on installation as well as later. Interface and all its video-inputs can be operated with analogue trigger signals, without connection to vehicle CAN-bus. Yet, in this case, some features do not work, see chapter 2.4.2 *Analogue connection without CAN-bus*

#### *Video only*

Interface inserts **only video-signals** into the infotainment. To insert audio signals a possibly existing factory audio-AUX-input or other optional products (e.g. FM-Modulator) must be used. For HDMI source, the audio is output via an analogue audio output (3.5mm jack socket).

#### *Factory rear-view camera*

Automatic switching to factory rear-view camera input is only possible while reverse gear is engaged. For deviating switching times optional accessories are required.

#### *After market front camera*

Front camera will automatically be switched to for 5, 10, 15 or 20 seconds (depending on menu setting) after disengaging the reverse gear. Manual switching to front camera is possible by external keypad.

#### *Guide lines for rear-view camera*

If the vehicle CAN bus is not fully compatible with the interface or if the connection is analogue, the moving guide lines function cannot be used.

#### *Factory TV tuner*

Not compatible with vehicles with factory TV tuner. Tuner then no longer displays a picture.

#### *Vehicles with active Park assistant system 235*

While the factory active park assistant system 235 is in use, the displaying of a camera picture is not possible.

## 1.3 Boxes and connectors - interface

The interface converts connected after-market sources' video-signals into a video-signal compatible with the factory monitor. It can then be inserted, using separate trigger options. The interface also reads the vehicle's CAN-bus signals and uses them for own functions.

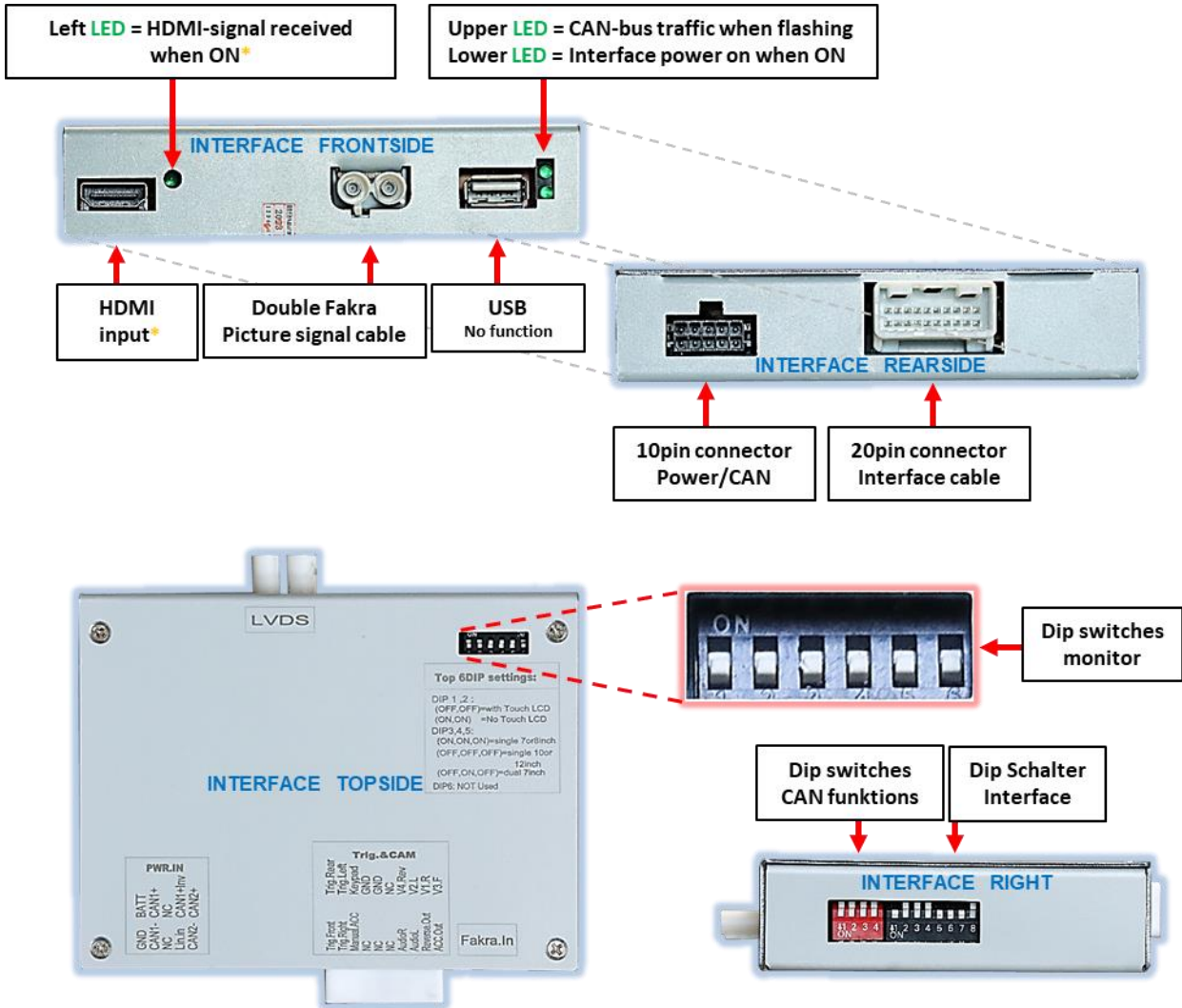

\* HDMI-input only available on HDV-MBN55

## 1.4 Settings - 8dip switch bench (interface functions)

Interface box, right side, black

Dip position **UP = OFF** and **DOWN = ON**.



Dip	Function	ON (down)	OFF (up)
1	Video 1 / V1-Left	enabled	disabled
2	Video 2 / V2-Right	enabled	disabled
3	Frontcamera / V3-Front	enabled *	disabled
4	Rear-view cam type (V4-Rear)	after-market	factory or none
5	Connection type of After-market rear-view camera *	<b>HDMI*</b>	V4-Reverse (FBAS/AHD)
6	<b>HDMI-Input*</b>	enabled	disabled
7	Monitor selection	8inch monitor	10.25 + 12inch monitor
8	Monitor selection	8inch monitor	10.25 + 12inch monitor

**Power reset interface after each dip change to activate changes!**

\* The front camera will automatically be switched for 5, 10, 15 or 20 seconds after disengaging reverse gear (depending on OSD-menu setting).

\* On **HDA-MBN55**, dip 5 and dip 6 have no function. Set both **OFF**.

See following chapters for detailed information about 8dip switch bench.

### 1.4.1 Video inputs **V1-Left** and **V2-Right** (dip 1-2)

With dip 1 (dip 2) = **ON**, the CVBS/AHD input **V1-Left** (**V2-Right**) for side-camera or other video-sources is enabled. Only enabled video inputs can be accessed – no matter whether automatically or manually switched. We recommend to enable only used inputs to avoid unwanted switching.

### 1.4.2 Front camera input **V3-Front** (dip 3)

With dip 3 = **ON** the interface switches to its CVBS/AHD front camera input **V3-Front** after disengagement of reverse gear. Additionally, manual switching to front camera input is possible by the external keypad (short press) from any video mode.

In the OSD-menu settings it is possible to set the automatic front camera display time from 5, 10; 15 or 20 seconds or shut it off. Therefore, it is also possible to connect a video-source other than from camera.

### 1.4.3 Rear-view camera settings (dip 4)

With dip 4 = **OFF**, the interface switches to factory picture while reverse gear is engaged, to display factory rear-view camera or factory optical park system picture.

With dip 4 = **ON**, while the reverse gear is engaged the interface switches to its CVBS/AHD rear-view camera input **V4-Reverse** (provided that dip 5 is set to **OFF**) or to its **HDMI-input\*** (provided dip 5 and dip 6 are set to **ON**).

**Note:** **V4-Reverse** remains without function with HDMI rear-view camera (dip 5 = ON).

### 1.4.4 Rear-view cam connection type (dip 5)

With dip 5 = **ON**, the **HDMI-input\*** will be used as rear-view camera input. Additionally, the **HDMI-input\*** must be enabled with dip 6 = ON.

With dip 5 = **OFF**, the **V4-Reverse** input is used as rear-view camera input.

**Note:** Automatic switching to front camera for the pre-set time, after disengaging reverse, is working in both cases.

### 1.4.5 HDMI-input\* (dip 6)

With dip 6 = **ON**, the **HDMI-input\*** is enabled and can be used for various HDMI-sources (e.g., rear-view camera or 360° camera-system, smartphone, laptop, streaming stick, DVB-T2 tuner, etc.). For rear-view camera or 360° camera system, additionally set dip 5 = **ON**.

With dip 6 = **OFF**, the **HDMI-input\*** is disabled.

### 1.4.6 Monitor selection (dip 7+8)

Dips 7 and 8 are used to set the size of the monitor.

Monitor size/vehicle	Dip 7	Dip 8
8inch monitor	<b>ON</b>	<b>ON</b>
10.25inch and 12inch monitors	<b>OFF</b>	<b>OFF</b>

\* **HDMI-input only available on HDV-MBN55**

**Power reset interface after each dip change to activate changes!**

## 1.5 Settings - 6dip switch bench (monitor definition)

Interface box, top side, black

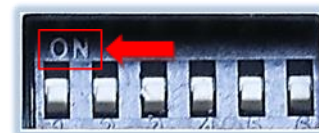

**Attention: Opposite to other dip benches (8dip and 4dip), the 6dip position here is **UP = ON** and **DOWN = OFF**!**

**Attention!**  
Flip the dip switch very carefully with a micro tool.

Monitor type and size	Dip 1	Dip 2
With Touch LCD	OFF	OFF
Without Touch LCD	ON	ON

Monitor type and size	Dip 3	Dip 4	Dip5	Dip6
8inch single monitors	ON	ON	ON	OFF
10 and 12inch single monitors	OFF	OFF	OFF	OFF
8inch dual monitors	OFF	ON	OFF	OFF

Note: Dip6 is out of function and has to be set to OFF.

If picture- or touch problems appear, try also the other dipswitch settings!

Power reset interface after each dip change to activate changes!

## 1.6 Settings - 4dip switch bench (CAN-bus)

Interface box, right side, red

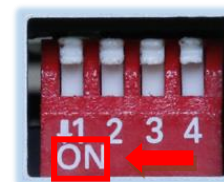

Set dips according to below table.

Dip position **UP = OFF** and **DOWN = ON**.

Vehicle/Navigation	Dip 1	Dip 2	Dip 3	Dip 4
All vehicles	OFF	OFF	OFF	OFF
Vehicles with factory active park assistant system 235	ON	OFF	OFF	OFF

**Note:** During the use of the factory active park assistant system 235, no camera image is available.

Power reset interface after each dip change to activate changes!

## 2 Installation

For installation, first switch off the ignition and disconnect the vehicle's battery following the instructions of the vehicle manufacturer regarding battery disconnection! If disconnecting battery is not suggested, enable vehicle sleep-mode (hibernation mode).

In case the sleep-mode does not succeed, the disconnection of battery can be done with a resistor lead.

Before final installation, a test-run of interface and all connected devices is recommended to ensure compatibility of the complete installation. Due to at any time possible changes in the vehicle manufacturers' productions, incompatibilities can never be ruled out.

As on any installation of retrofit equipment, a stand-by test is necessary after installation to ensure that the retrofit products switch off after the vehicle enters sleep mode.

### 2.1 Place of installation

Depending on the vehicle model, the place of connection of the MBUX head unit to which the connection is made, varies.

 Caution: On the **G-model (W463)**, **S-coupé (C217)** and **S-class (V/X/W222)** the installation location is behind the centre console. This means that the installation is considerably more time-consuming (see picture).



Connection-picture signal cable:

The interface's standard connection has to be done at the head unit's **ocher coloured** double Fakra connector. As there are several Audio 20 NTG 5.5 head units without that **ocher coloured** double Fakra connector, this connection has to be done at the **blue coloured** double Fakra connector. In that case, the cables of each according double Fakra connectors have to be exchanged. (refer to chapter „Special case: Connection to the picture signal cable (blue coloured double Fakra“).

# Manual

## 2.2 Connection schema

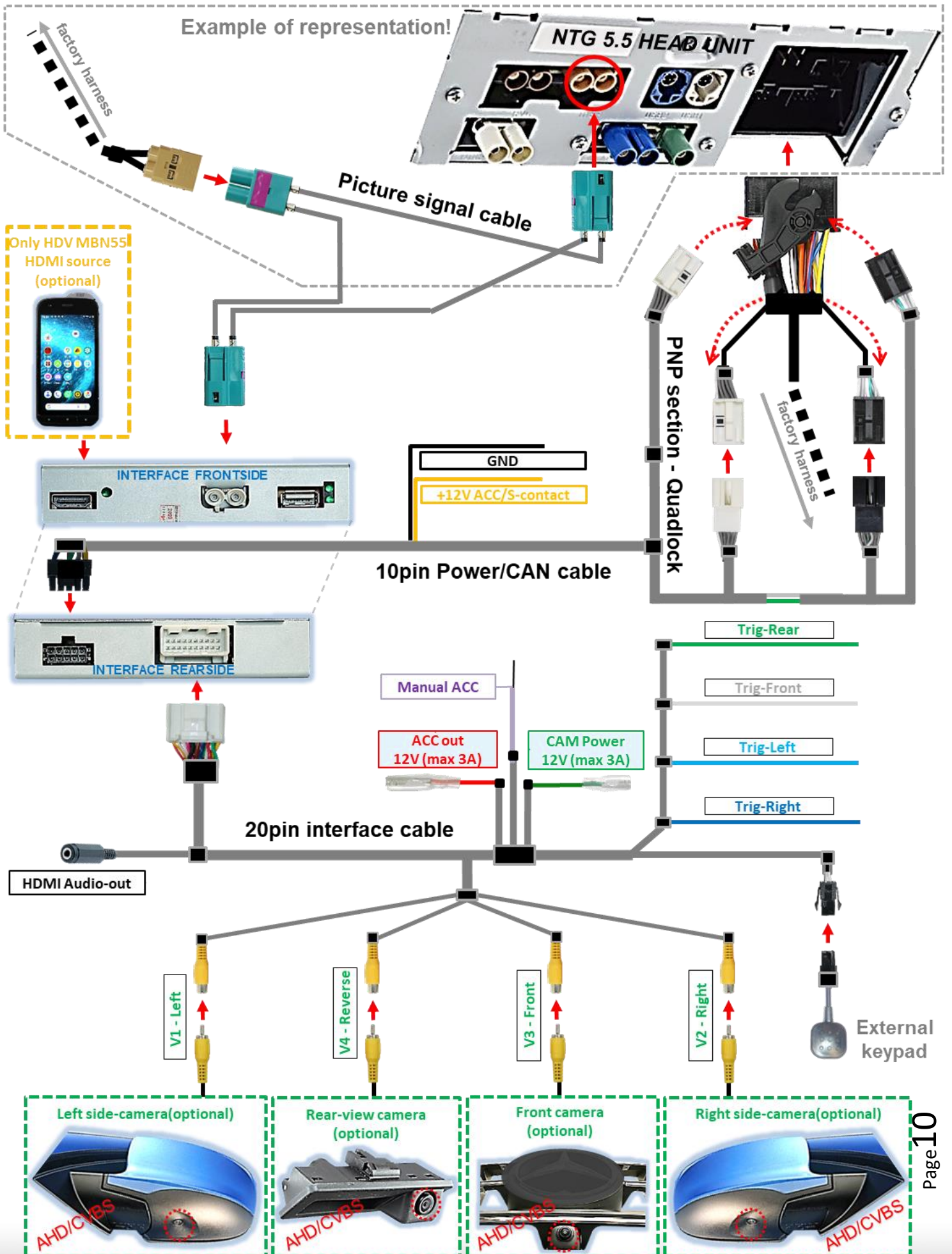

### 2.3 Connection - picture signal cable

#### 2.3.1 Standard connection - picture signal cable (ocher coloured double Fakra)

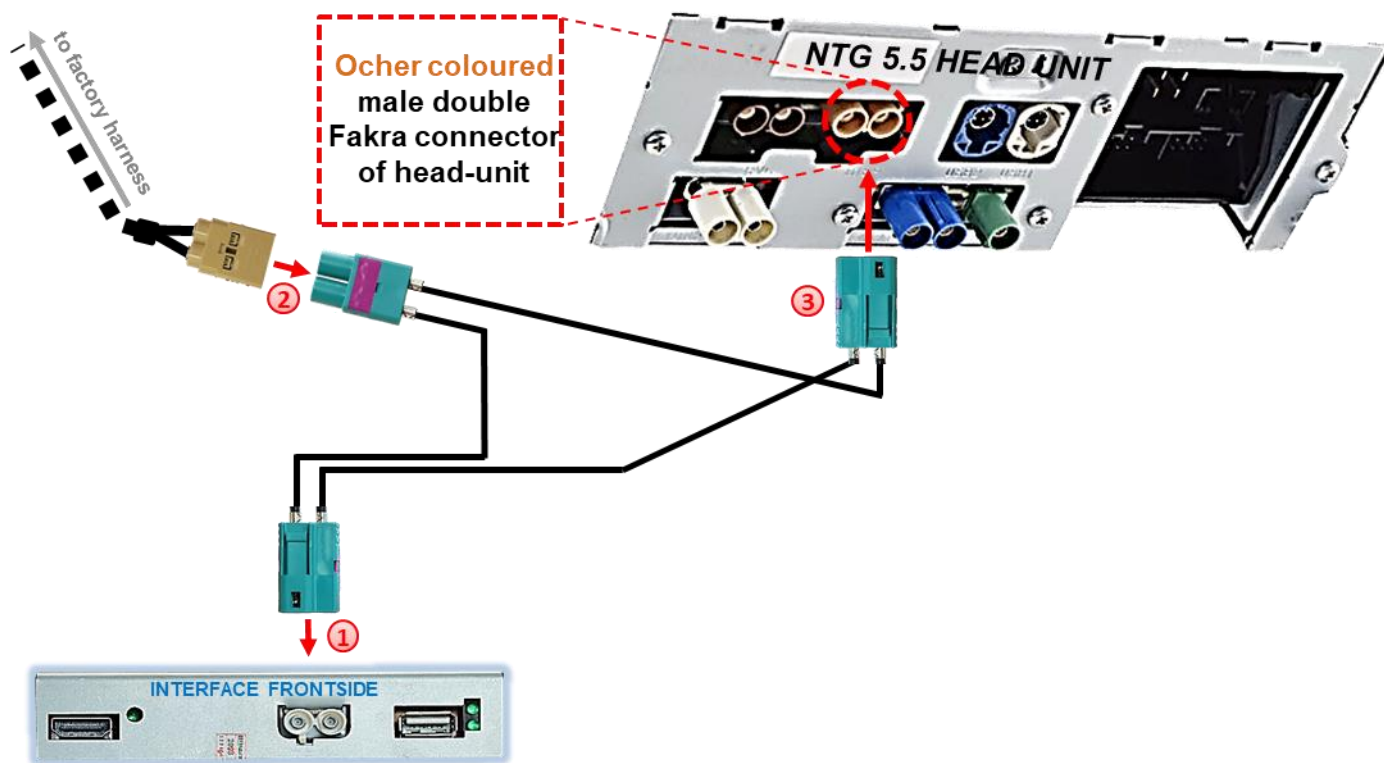

- 1 Connect the picture signal cable's **green** female double Fakra connector to the male double Fakra connector of the video interface.
- 2 Disconnect the **ocher-coloured** female double Fakra connector from the rear-side of the head unit and connect it to the picture signal cable's **green-coloured** male double Fakra connector.
- 3 Connect the picture signal cable's opposite **green-coloured** female double Fakra connector to the **ocher-coloured** male double Fakra connector at the rear-side of the head unit.



**Note:** The double Fakra connectors of the head unit may not be save for confounding. Please be sure to take attention for the right colouring (**ocher**)!

### 2.3.2 Special case: Connection - picture signal cable (blue double Fakra)

As there are several Audio 20 NTG 5.5 head units without that other-coloured double Fakra connector, this connection has to be done at the blue coloured double Fakra connector.

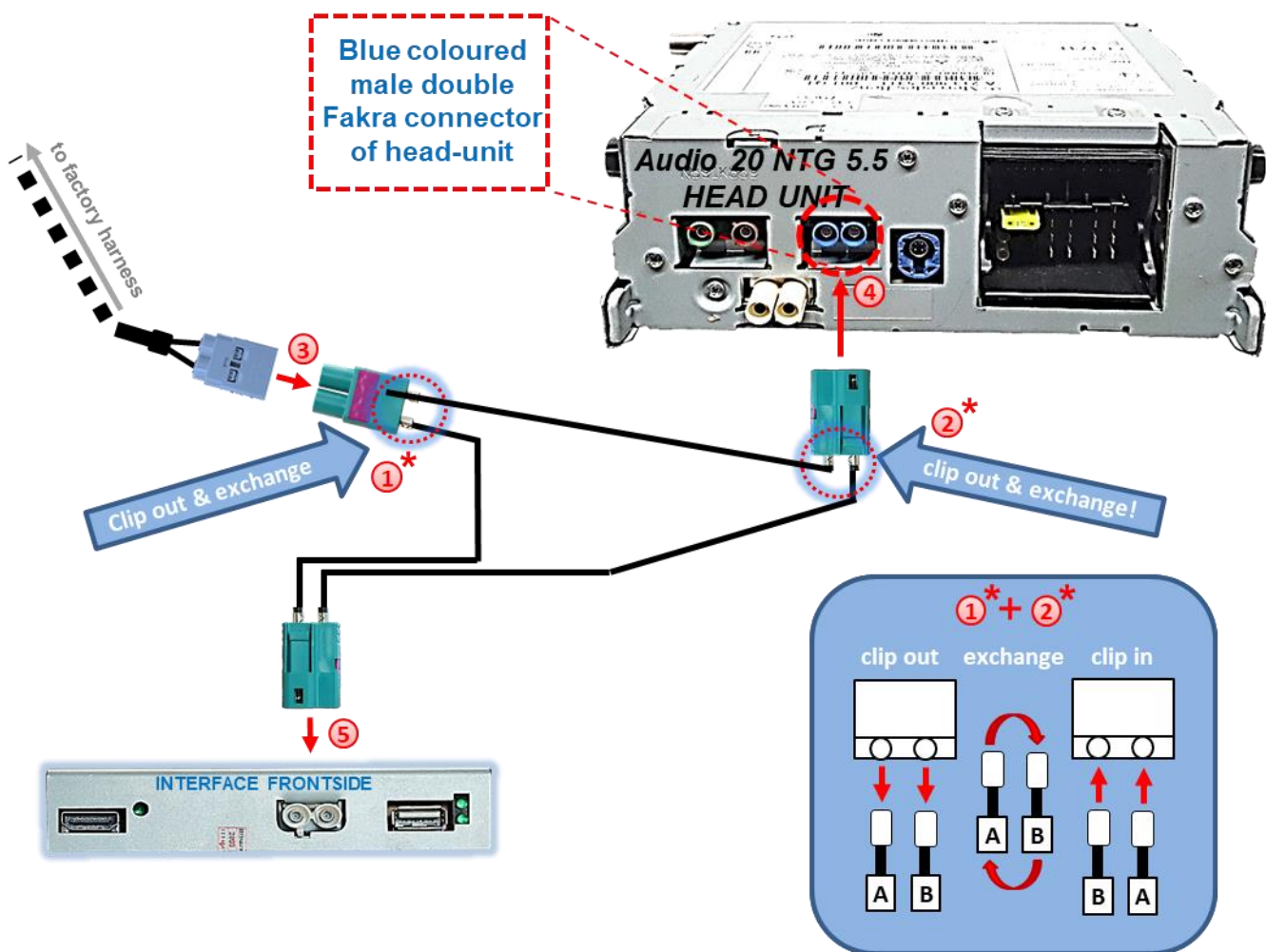

- ❶ Unlock the picture signal cable's **green** male double Fakra connector's locking mechanism, clip out both cables to exchange them (see the blue diagram), clip in the exchanged cables and again lock the connectors locking mechanism.
- ❷ Unlock the locking mechanism of the picture signal cable's **green** female double Fakra connector „**Connect behind head unit**“, clip out both cables to exchange them (see the blue diagram), clip in the exchanged cables and again lock the connectors locking mechanism (same procedure as done with the green male double Fakra connector before)
- ❸ Disconnect the **blue** female double Fakra connector of the factory harness at the rear-side of the head unit and connect it to the picture signal cable's **green** male double Fakra connector (with previously exchanged cables)
- ❹ Connect the picture signal cable's **green** female double Fakra connector „**Connect behind head unit**“ (with previously exchanged cables) to the head unit's male **blue** double Fakra connector.
- ❺ Connect the picture signal cable's female **green** double Fakra connector to the male double Fakra connector of the video interface.

### 2.4 Connection – harnesses, power supply and CAN-bus or analogue without CAN-bus

The interface can be integrated via CAN-bus as well as operated in analogue mode without CAN-bus connection.

When integrated via CAN-bus, the interface is switched on by the vehicle CAN-bus and R-gear signal and turn signals are usually recognized. In some vehicles also movable guide lines can be displayed, using CAN-bus steering signals and parking sensor data.

Exceptionally, the CAN-communication is not (fully) compatible. If after connection of **10pin power/CAN cable** with ignition on, no interface LED is on, the analogue connection described hereinafter must be made. Also, to avoid possible afterwards CAN-bus incompatibility, an analogue connection is also possible. Thereby the interface must be switched on as well as switched over to its inputs by +12V switch inputs.

**The display of movable guide lines for the rear-view camera is omitted with an analogue connection.**

No matter whether connection is done with CAN-bus or analogue without CAN-bus, **black GND wire** and **yellow +12V ACC/S-contact wire** of 10pin power/CAN cable must be connected.

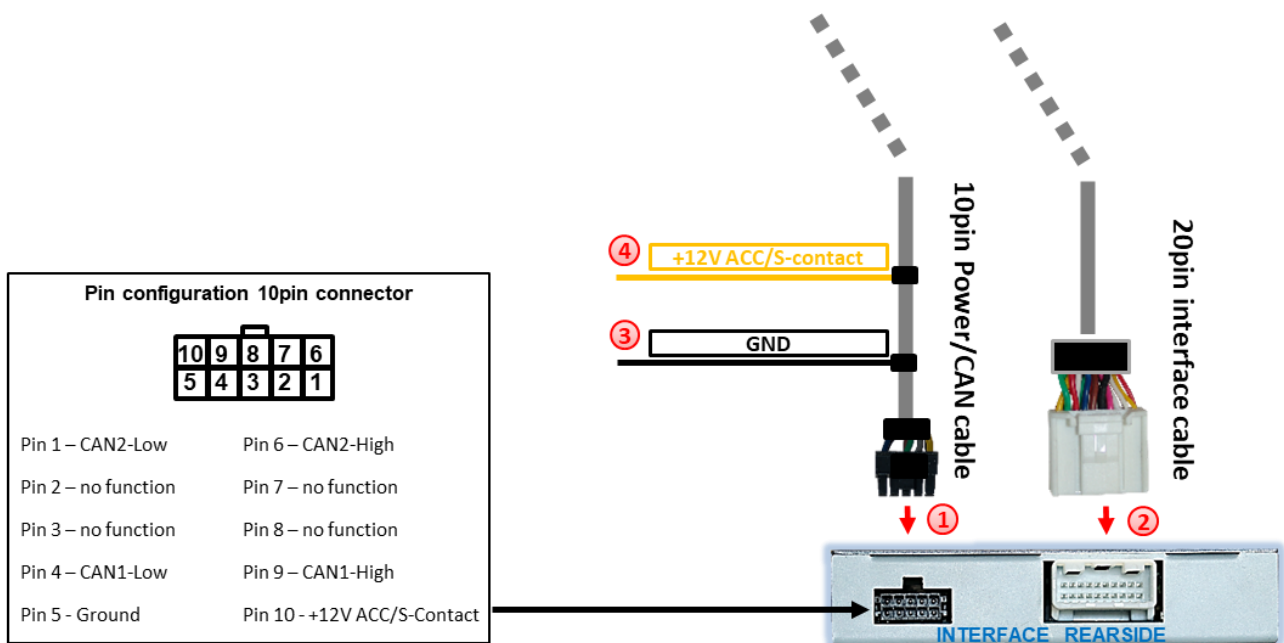

- ① Connect female 10pin connector of **10pin power/CAN cable** to male 10pin connector of interface.
- ② Connect female 20pin connector of **20pin interface cable** to male 20pin connector of interface.
- ③ Connect **black GND wire** of **10pin power/CAN cable** to stabile vehicle's negative ground.
- ④ Connect **yellow +12V ACC/S-contact wire** of **10pin power/CAN cable** to **+12V ACC (terminal 15r) or S-contact (terminal 86s)** of vehicle.



**Hinweis:** Ein Anschluss an +12V Batterie (Klemme 30) ist technisch ebenfalls möglich. Dabei kann dann aber nicht ausgeschlossen werden, dass im Fall einer (teilweisen) CAN-Bus Inkompatibilität oder eines Defekts das Interface sich im Sleep-Modus nicht abschaltet. Ein Anschluss an +12V Batterie (Klemme 30) erfolgt auf eigene Gefahr!



### 2.4.2 Analogue connection without CAN-bus

With analog connection, the four CAN wires of the 10-pin power/CAN cable must not be connected - for this, the four wires of the 10-pin power/CAN cable have to be disconnected!

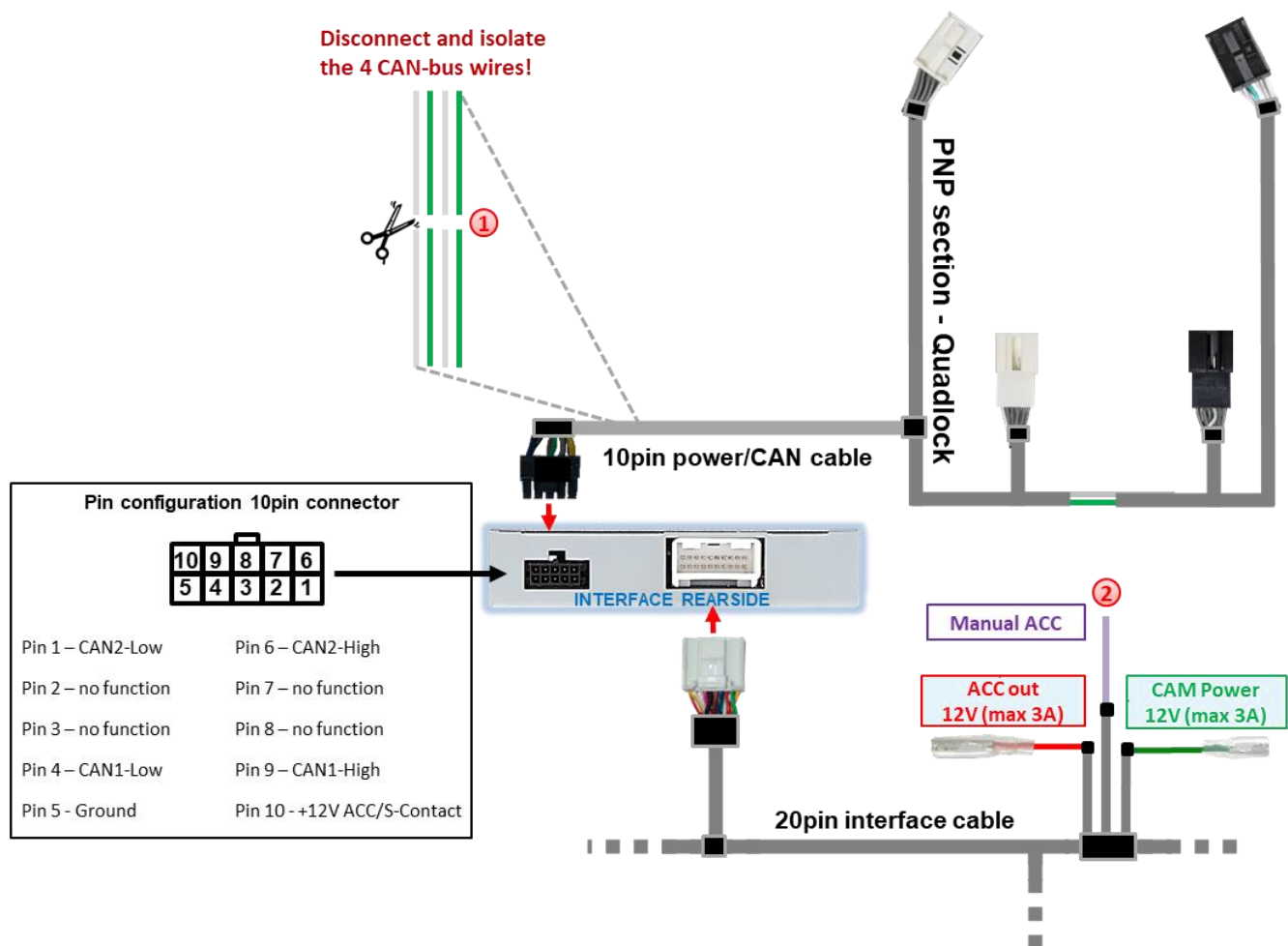

- 1 Disconnect and isolate the 4 CAN bus wires (2X white and 2X green) of the 20pin interface cable about 4-5 cm behind the black connector.
- 2 Connect purple wire Manual ACC of 20pin interface cable to +12V S-contact terminal 86s or ACC terminal 15r of vehicle (e.g., cigarette lighter, glove compartment illumination).



#### Notes

- Only as long as the interface is switched on via +12V on Manual ACC, the monitor can show picture. Otherwise, also the factory picture is black. When selecting the switch-on signal, please check whether the factory picture is available in all desired operating states.
- The display of movable guide lines for the rear-view camera is omitted with an analogue connection.
- With analogue connection of interface (without CAN-bus), the connection of rear-view camera and side-cameras must also be made analogue. See chapters:  
 2.6.2 Case 2: Reverse signal from analogue signal  
 2.8.2 Case 2: Turn signal from analogue signal

### 2.5 Power supply outputs

The two **red** and **green** power supply cables **ACC out 12V (max 3A)** and **CAM power 12V (max 3A)** of the **20-pin interface cable** can be used either as ACC power supply for **external video-sources** connected to the inputs **V1-Left, V2-Right, V3-Front** or **HDMI-input\*** (e.g., iOS/Android devices, laptop, streaming stick, DVB-T2 tuner), or as power supply for the **after-market cameras** connected to the **V1-Left, V2-Right, V3-Front, V4-Reverse** or **HDMI-input\*** (e.g., rear-view, front and side-cameras).

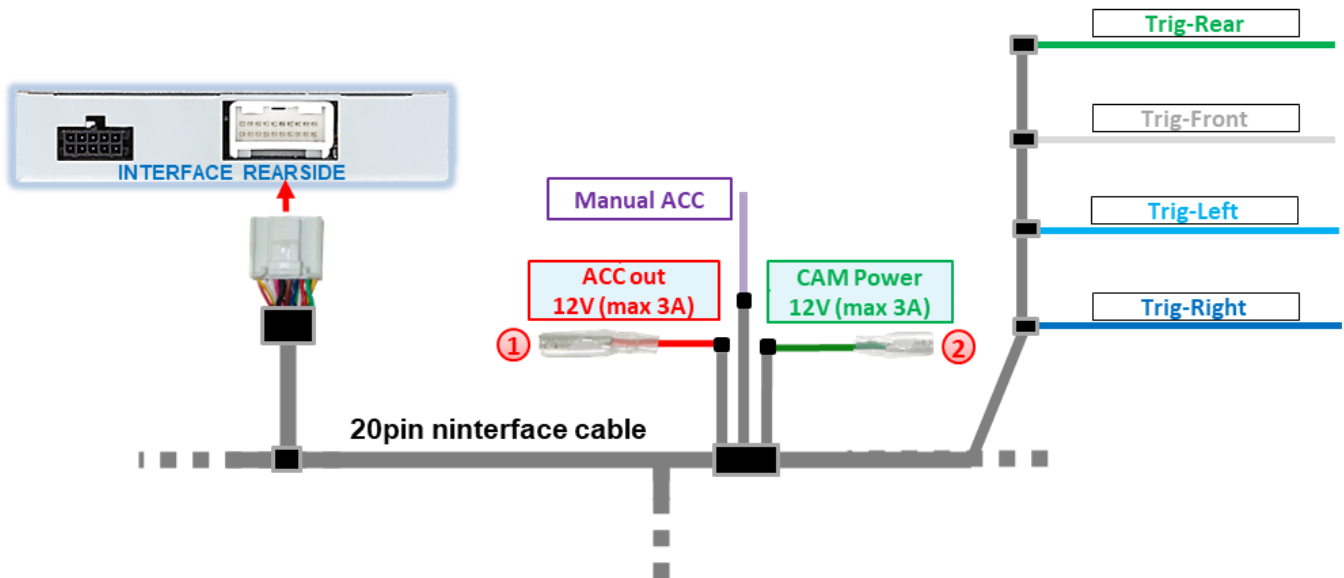

- ① **External video-sources** (no cameras) can be supplied with power via the red power supply cable **ACC out 12V (max 3A)** of the **20pin interface cable**. The cable carries +12V ACC trigger out power **permanently** while interface is powered (see following chapters for connection).
- ② The power supply for **after-market cameras** (e.g., rear-view, side and/or front camera) can be supplied by the green power supply cable **CAM power 12V (max 3A)** of the **20pin interface cable**. The cable carries **+12V trigger out power** exclusively as long as any of the camera inputs is shown, regardless of whether the switching is by vehicle CAN-bus or by trigger wires (see following chapters for connection).

\* **HDMI-input only available on HDV-MBN55**

### 2.5.1 Connection and power-supply - video-sources rear-view camera, front camera and 2 side-cameras

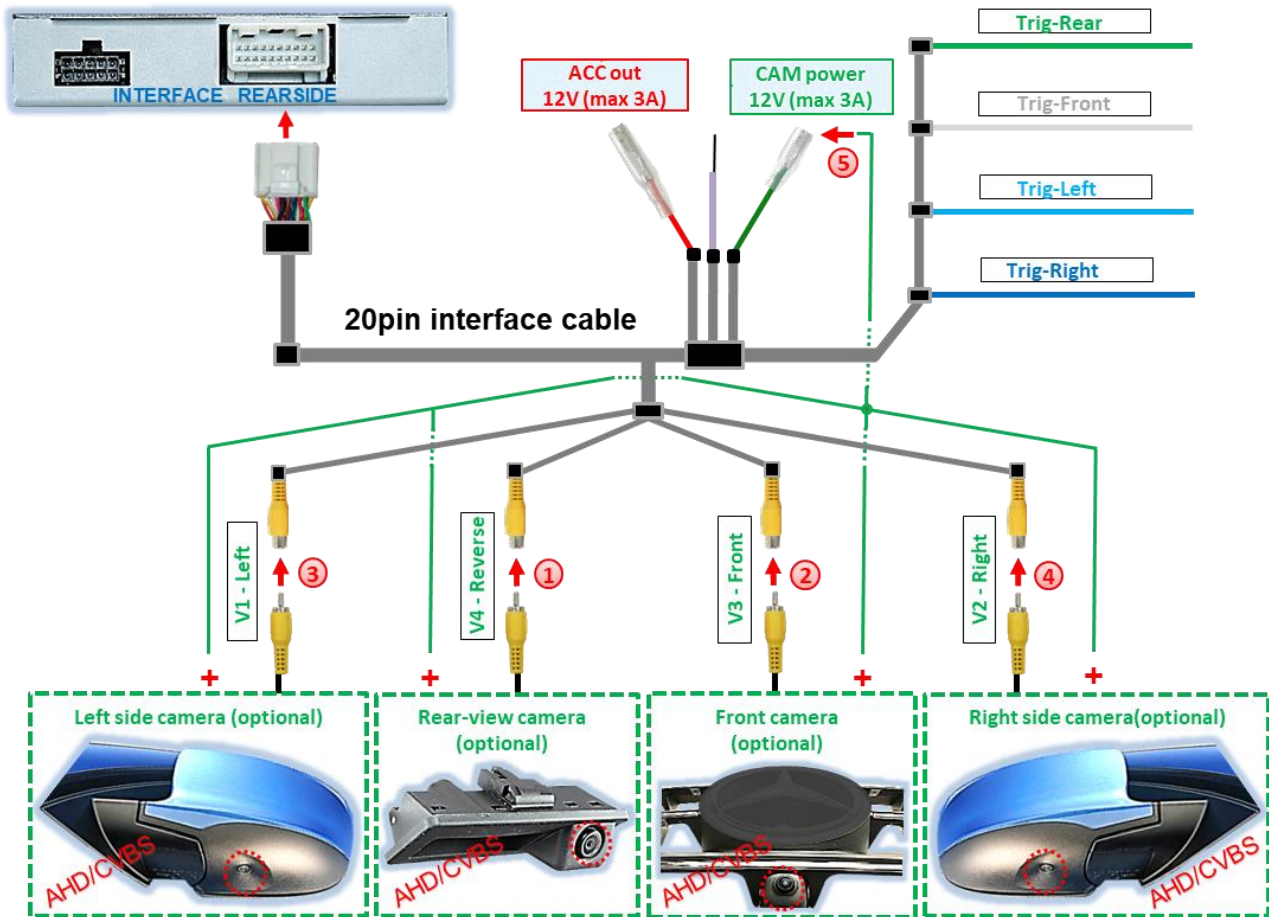

- ① Connect male RCA connector of rear-view camera to female RCA connector **V4-Reverse** of 20pin interface cable.
- ② Connect male RCA connector of front camera to female RCA connector **V3-Front** of 20pin interface cable.
- ③ Connect male RCA connector of left side-camera to female RCA connector **V1-Left** of 20pin interface cable.
- ④ Connect male RCA connector of right side-camera to female RCA connector **V2-Right** of 20pin interface cable.
- ⑤ Connect power supply for all after-market cameras to **green wire CAM power +12V (max 3A)** of 20pin interface cable.



**Note:** The type of camera switching (by CAN-bus or trigger cables) can be preset in the OSD-menu settings individually for each input.

**Attention!**  
Video signal type of each video source must be preset in OSD-menu of corresponding video-input.

### 2.5.2 Connection and power-supply - video-sources rear-view camera, front camera and 2 video-sources

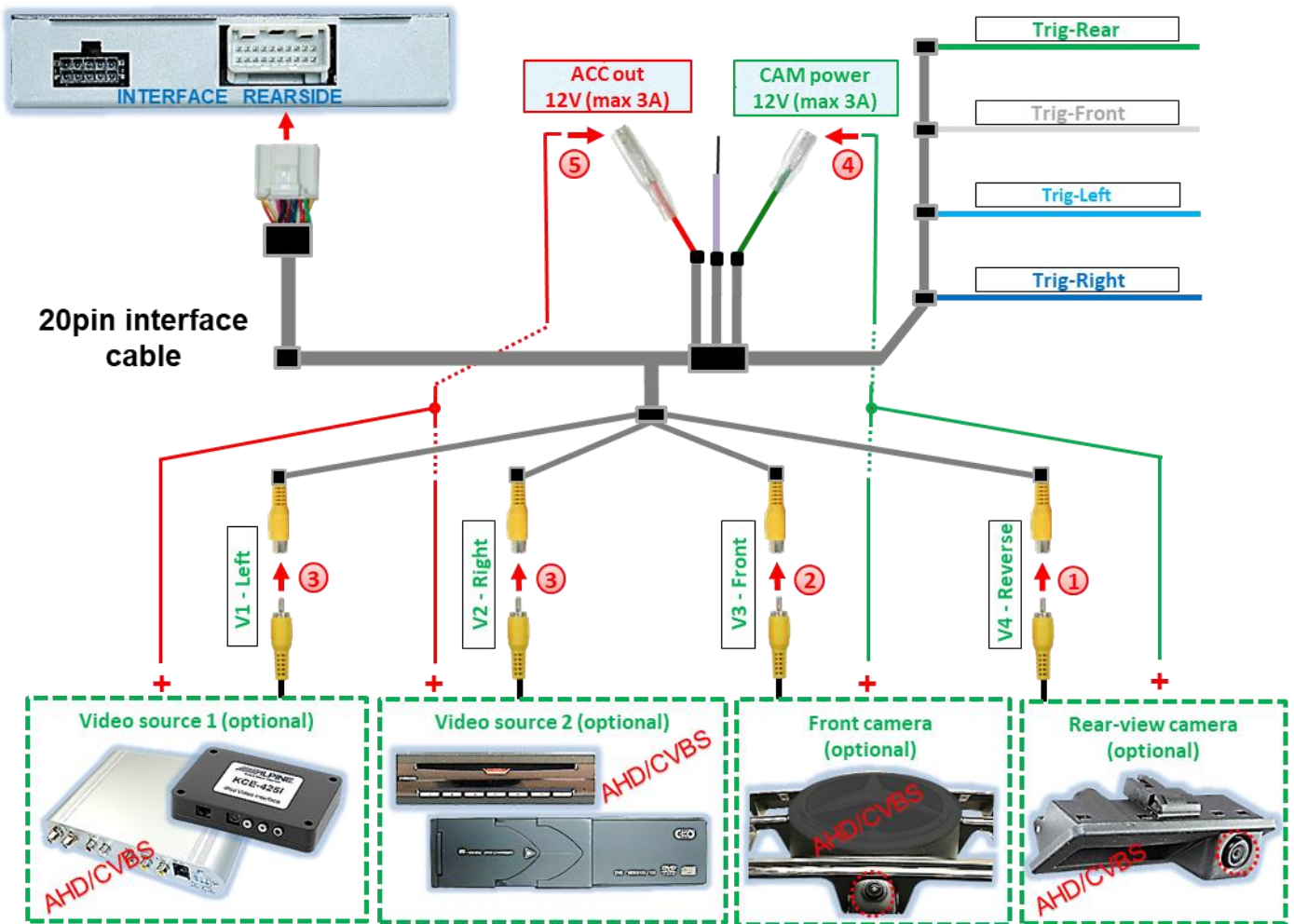

- ① Connect male RCA connector of rear-view camera to female RCA-connector **V4-Reverse** of 20pin interface cable.
- ② Connect male RCA connector of front camera to female RCA-connector **V3-Front** of 20pin interface cable.
- ③ Connect male RCA connectors of video-source 1 and 2 to female RCA connectors **V1-Left** and **V2 Right** of 20pin interface cable.
- ④ Connect power supply for after-market cameras to **green cable CAM power +12V (max 3A)** of 20pin interface cable.
- ⑤ Connect power supply for other video-sources to **red cable ACC out +12V (max 3A)** of 20pin interface cable.



**Note:** The type of camera switching (by CAN-bus or trigger cables) can be preset in the OSD-menu settings individually for each input.

**Attention!**  
Video signal type of each video source must be preset in OSD-menu of corresponding video-input.

### 2.6 After-market rear-view camera

Automatic switching to rear-view camera is possible by CAN-bus or by analogue reverse signal.

#### 2.6.1 Case 1: Reverse signal by CAN-bus

Basic requirement is that the interface is connected to CAN-bus. Furthermore, vehicle CAN-bus reverse signal and its detection by the interface must be compatible.

If so, interface supplies +12V on **green wire CAM power 12V (max 3A)** of 20pin interface cable while reverse gear is engaged and interface automatically switches to rear-view camera input **V4-Reverse** or **HDMI-input\***.

See also chapter 1.4 Settings - 8dip switch bench (interface functions).

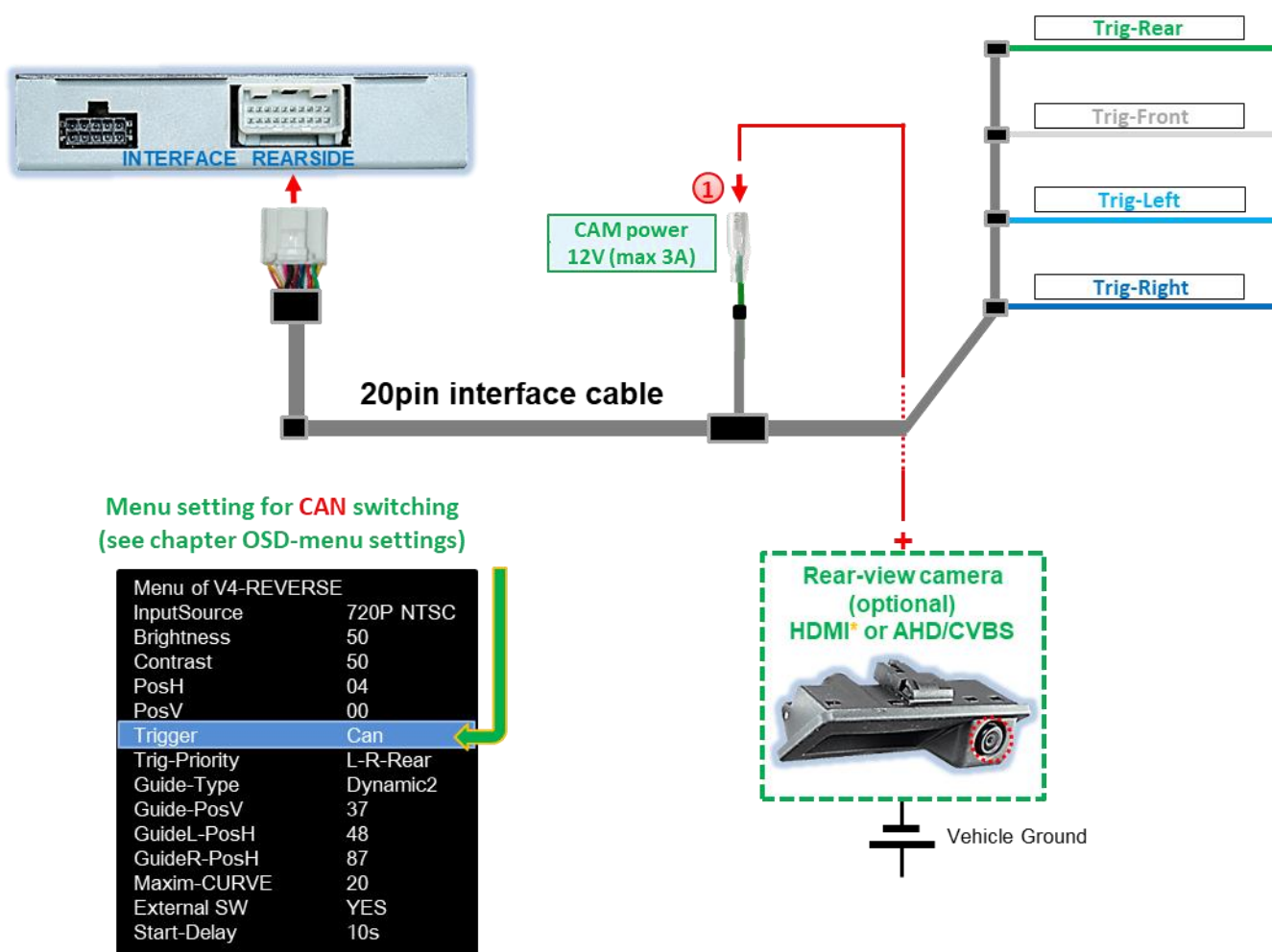

**1** The +12V (max. 3A) power supply for the rear-view camera can be taken from the **green wire CAM power 12V (max 3A)** of the 20pin interface cable, as it carries voltage only for the time of camera input activation (some cameras are not continuously current-stable).



#### Notes

If **HDMI-input\*** is defined as rear-view camera input by dip 5, **V4-Reverse** input remains without function!

If reverse gear detection of interface by CAN-bus does not work, reverse gear signal has to be connected analogue.

\* **HDMI-input only available on HDV-MBN55**

### 2.6.2 Case 2: Reverse signal from analogue signal

When connected the interface without CAN bus or when connected with CAN bus, if reverse gear is engaged and the interface does not provide +12V on the **green wire CAM Power 12V (max 3A)** of the **20pin interface cable** (not all vehicles are compatible), an external reversing light switch signal is required. As the power supply of reverse gear light is not voltage-stabile all the time, a normally open relay (e.g., AC-MR-312 or AC-MR-201) or filter (e.g., AC-PNF-RVC) is required. The diagram below shows the connection with relay.

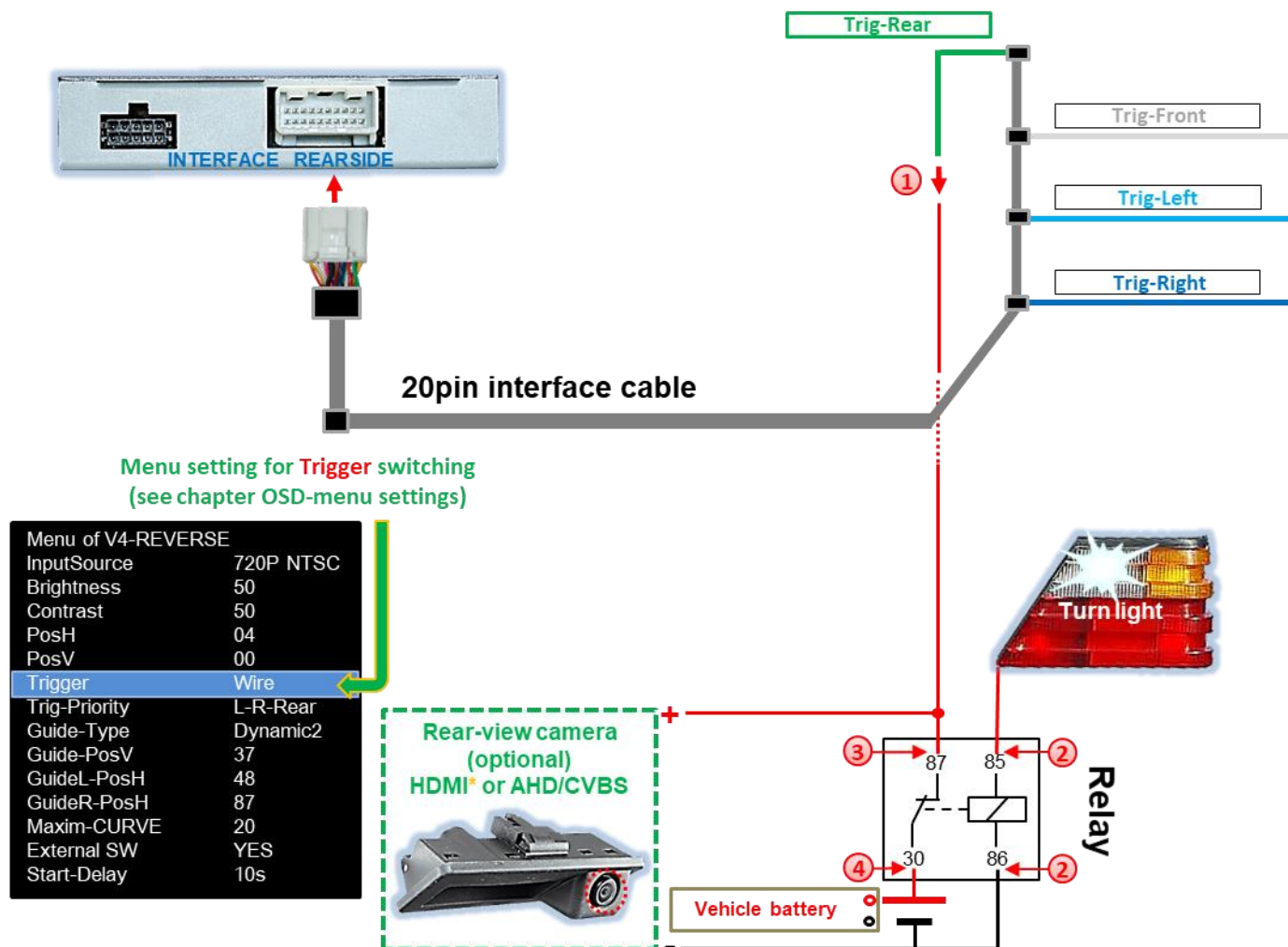

- ① Connect **green wire Trig-Rear** to output connector (87) of relay.
- ② Connect the power cable of vehicle reverse light to relay coil (85) and vehicle ground to relay coil (86).
- ③ Connect output connector (87) of relay to power cable of rear-view camera, additionally to **green wire Trig-Rear**.
- ④ Connect stabile and permanent +12V to input connector (30) of relay.

\* **HDMI-input only available on HDV-MBN55**

### 2.7 After-market front camera

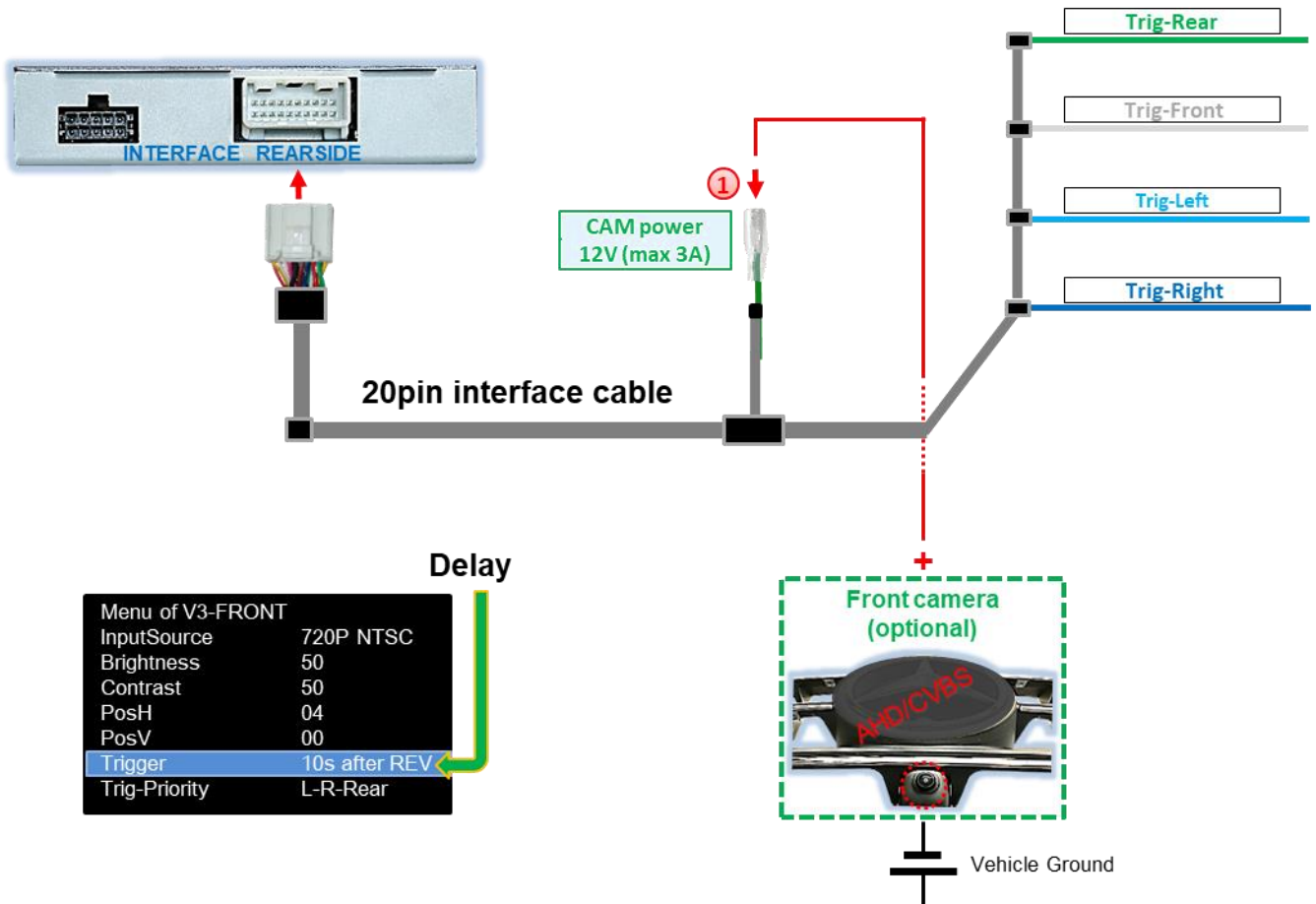

**1** The **green wire CAM power 12V (max 3A)** can be used to supply power to front camera (and all other cameras connected to the video inputs), as it only carries current for the duration of any camera activation (some cameras are not continuously current-stable). Requirement is dip 3 = **ON** (black 8dip switch bench). Then **green wire** carries +12V (max 3A) as power supply for the front camera as long as the front camera input is displayed.

The time of display delay can be selected individually for **5, 10, 15** or **20** seconds in the front camera OSD-menu settings.

Switching to front camera after disengaging reverse gear for the time set in the OSD-menu, takes place both, with connection by vehicle CAN-bus and with analogue connection of the rear camera.



**Note:** In addition, manual switching to front camera input (short press) is possible by external button from any image mode (see chapter 3 Interface operation)

### 2.8 After-market side-cameras

Side-cameras can be connected with switching by CAN-bus or analogue.

#### 2.8.1 Case 1: Turn signal from CAN-bus

Basic requirement is that the connection of the interface is made with CAN-bus. Furthermore, vehicle CAN-bus reverse signal and its detection must be compatible with the interface.

If so, interface supplies +12V on **green wire CAM power 12V (max 3A)** of 20pin interface cable for the duration of turn signal operations.

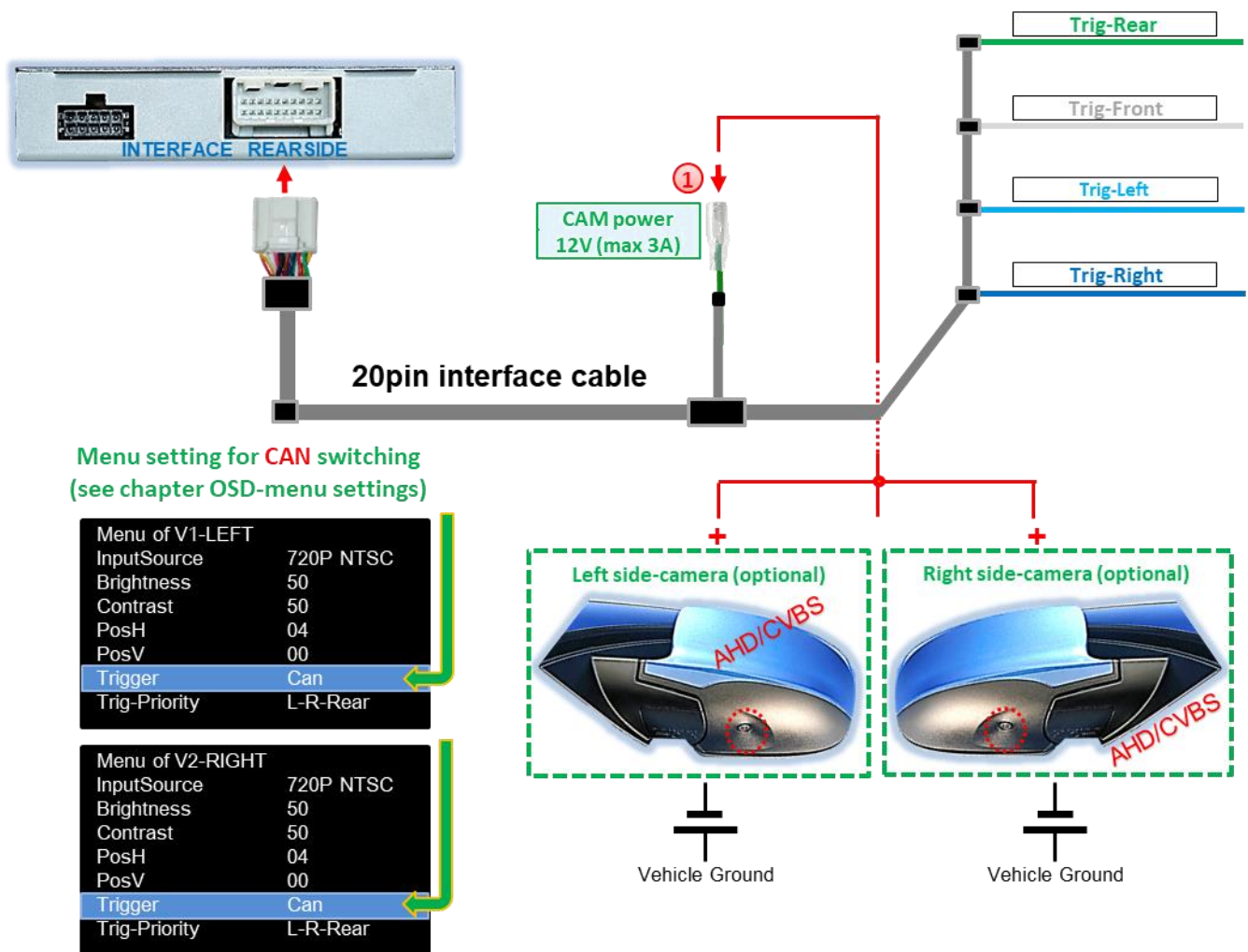

**1** Power supply for side-cameras should be connected to **green wire CAM power 12V (max 3A)** of **20pin interface cable**, as this cable is only powered during camera activation (some cameras are not continuously current stable).



**Note:** If turn signal detection of interface is not compatible with the vehicle CAN-bus, the turn signals must be connected analogue.

### 2.8.2 Case 2: Turn signal from analogue signal

When the interface is connected without CAN bus or when the interface is connected with CAN bus and the turn signals from the vehicle CAN bus are not recognised, an analogue activation of the side camera inputs is possible via the +12V switching input wires **Trig-Left** and **Trig-Right**. For switching to the side-camera inputs, an external switching signal from the turn signal bulb is required. Since the turn signal may contain electronic interference, for each input, a normally open relay (e.g., AC-RW-1230 with wiring AC-RS5) or a noise filter (e.g., AC-PNF-RVC) is required. The diagram below shows the connection of a normally open relay.

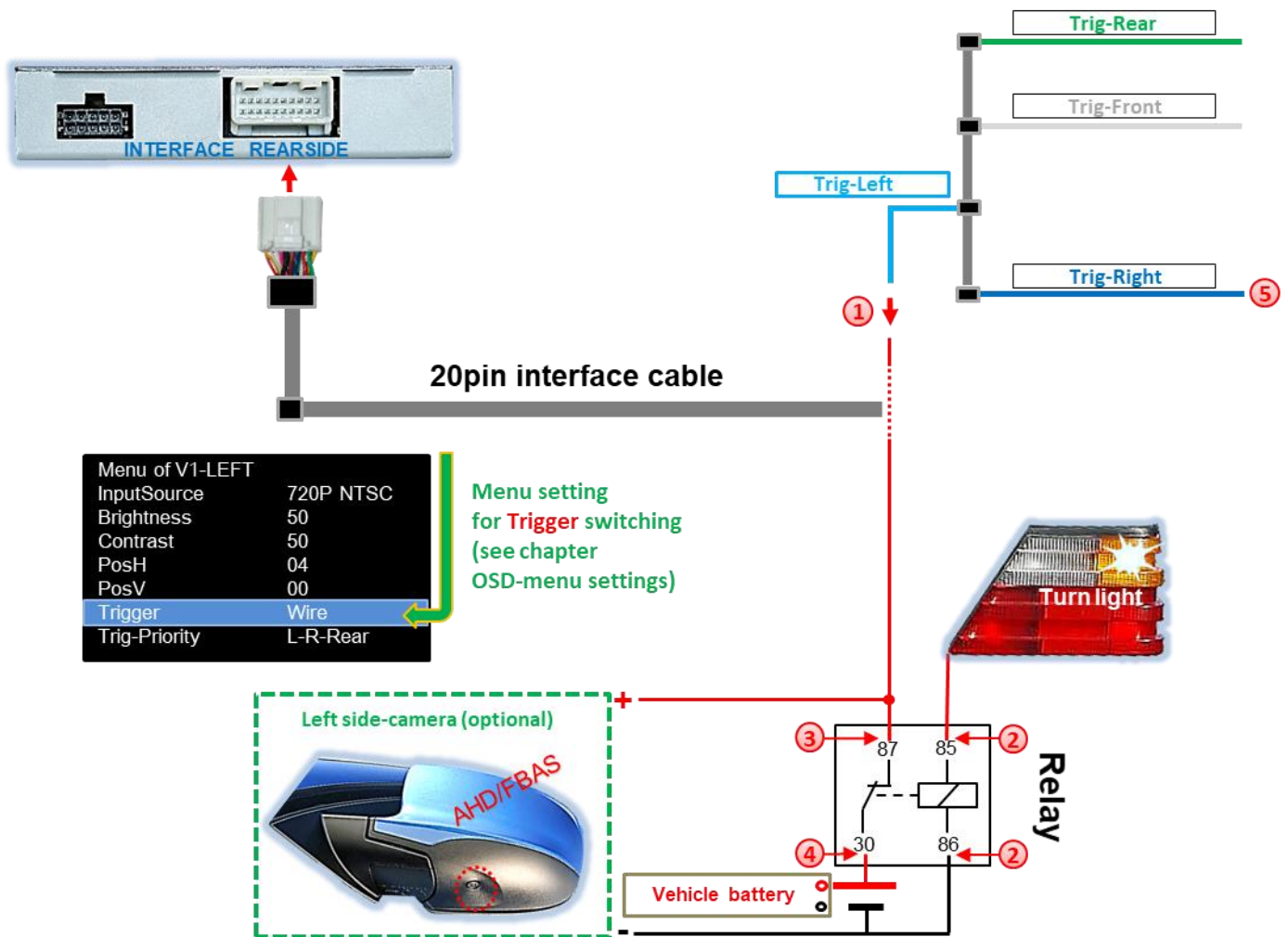

- 1 Connect **light blue wire Trig-Left** to output connector (87) of relay.
- 2 Connect power-cable of left turn signal to coil (85) of relay and coil (86) of relay to vehicle ground.
- 3 Connect output connector (87) of relay to power cable of rear-view camera, additionally to **light blue wire Trig-Left**.
- 4 Connect stable and permanent +12V to input connector (30) of relay.
- 5 Same connection applies to right side-camera just the **dark blue wire Trig-Right**.

### 2.9 HDMI rear-view camera or other HDMI-source (only HDV-MBN55)

The **HDMI-input\*** of the interface can generally be used for any video-source with HDMI-output, connected to it, e.g., rear-view camera, 360° camera-system or other video-source such as smartphones, laptop, streaming stick, DVB-T2 tuner, etc.

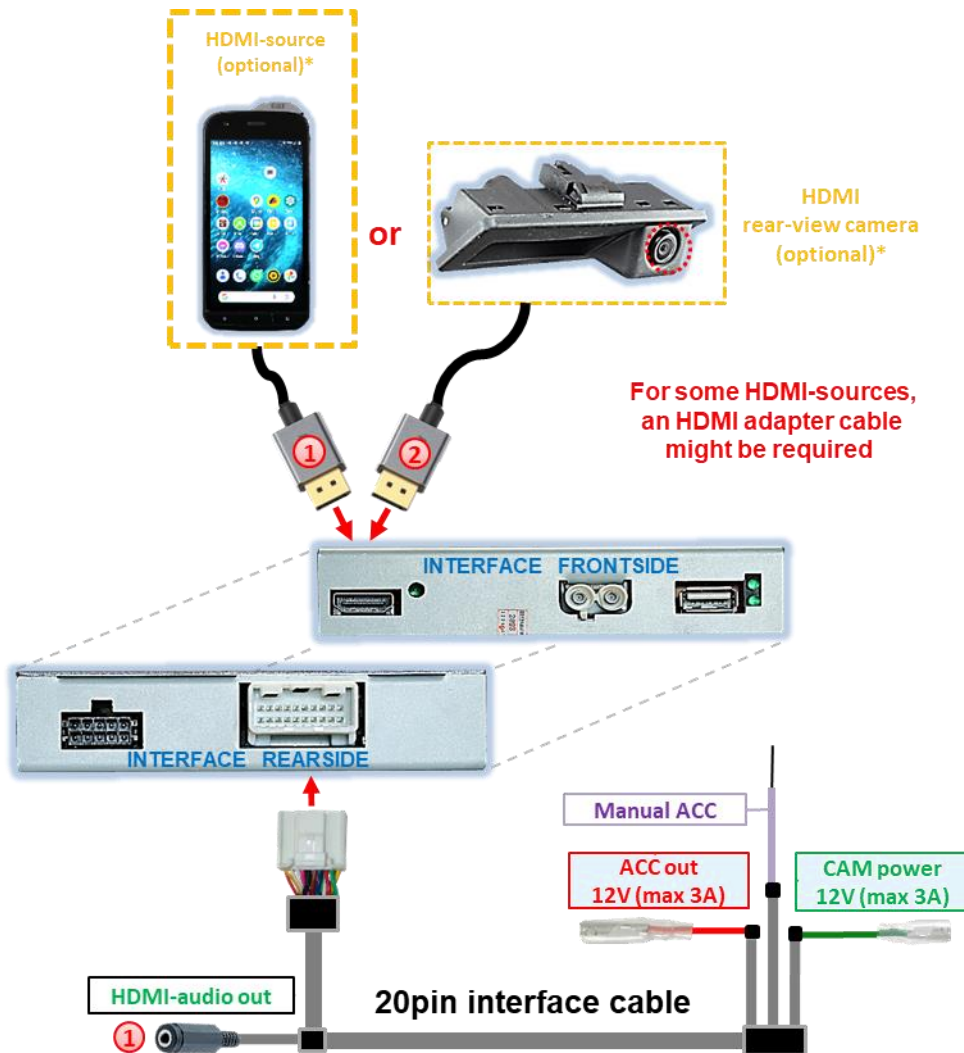

#### Picture settings in the HDMI menu

Menu of HDMI	
InputSource	AutoDetect
Brightness	50
Contrast	50
PosH	04
PosV	00

#### Picture settings in the HDMI menu for rear-view camera

Menu of HDMI-REVERSE	
InputSource	AutoDetect
Brightness	50
Contrast	50
PosH	04
PosV	00
Trigger	Can
Trig-Priority	L-R-Rear
Guide-Type	Dynamic2
Guide-PosV	37
GuideL-PosH	48
GuideR-PosH	87
Maxim-CURVE	20
External SW	YES
Start-Delay	10s

**1** If an optional HDMI video-source (e.g., smartphone, laptop, etc.) is connected to the **HDMI-input\***, the video shown on the display of the HDMI-source will be mirrored on the vehicle monitor. The video-signal from display-free sources (e.g., streaming stick, DVD-Player, DVB-T2 Tuner, etc.) will be displayed on the vehicle monitor. The power supply for the video-source can be taken from **red wire ACC out 12V (max 3A)**. Received audio signals will only be supplied by the female 3.5 mm jack connector **HDMI-Audio out\*** of the 20pin interface cable. See following chapter 2.10 Audio-insertion.

**2** If a rear-view camera or 360° camera-system is connected to the **HDMI-input\*** (switched to by CAN-bus or analogue), the image displayed while reverse gear is engaged, and the image of a front camera connected to **V3-Front** is also displayed for the preset time when reverse gear is disengaged. Power supply can be taken from **green wire CAM power 12V (max3A)**.

\* HDMI-input only available on HDV-MBN55

### 2.10 Audio-insertion

The interface can only insert video-signals into the factory infotainment. Audio signals of the **HDMI-input\*** are supplied through the 3.5 mm female jack connector **HDMI-Audio out\*** of the interface. For all AV-sources connected to the interface, their audio output must be connected factory AUX input or an optional audio-inserter (e.g., AUX-UNI0x, FM modulator). If several AV-sources are connected to the infotainment, an audio-switch might be required additionally.

Inserted video-signal can be switched simultaneously to any audio mode of the factory infotainment.

\* **HDMI-input only available on HDV-MBN55**

### 2.11 Connection - Interface and external keypad

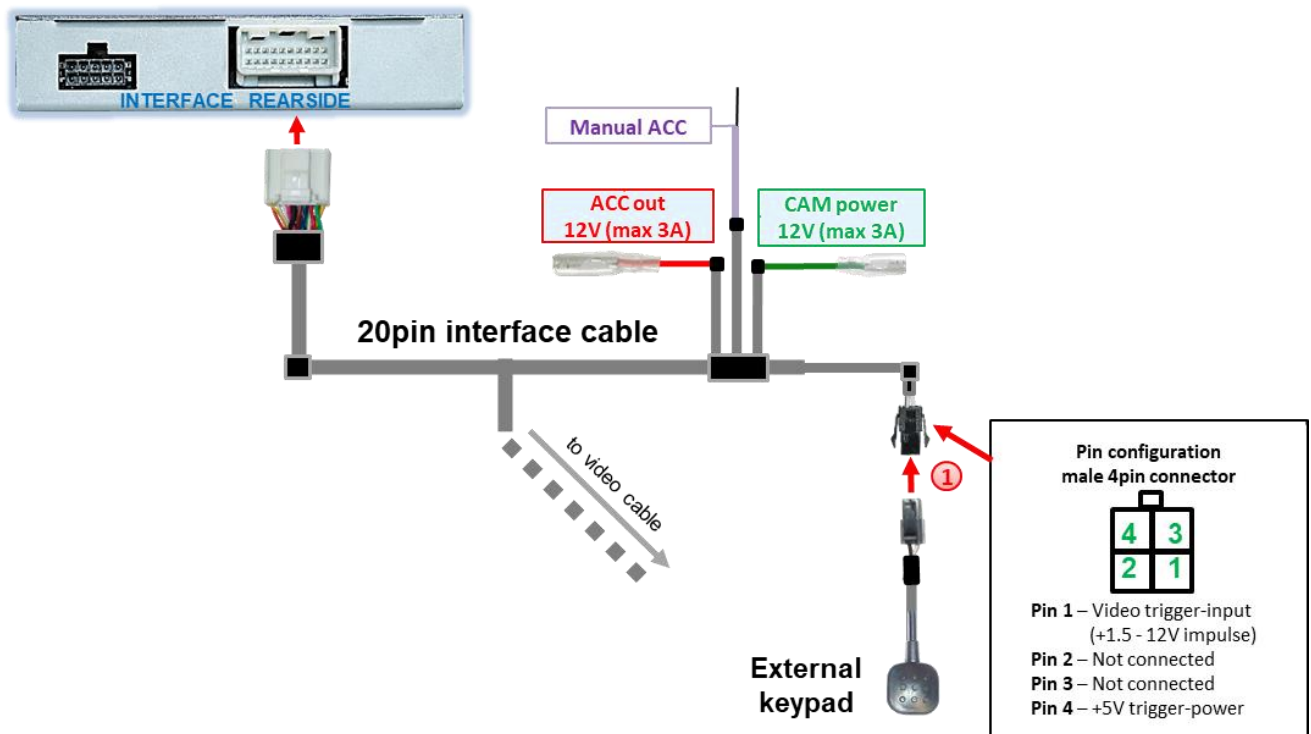

1 Connect female 4pin connector of keypad to male 4pin connector of 20pin interface cable.



**Note:** We recommend to install the external keypad for possible support reasons even if not required for customer needs. Make sure the external keypad is not installed "pressed" then.

**Optional:** Instead of the external keypad, the interface can also be operated using the optionally available remote control 'HDA-RC'. This enables direct selection of the video/camera inputs and more convenient changing of settings in the respective OSD menus.

\* The remote control is compatible with all HDA and HDV interfaces that are labelled with 'RC' at the end of the software version.



Remote control 'HDA-RC' optionally available

### 2.12 OSD-menu settings

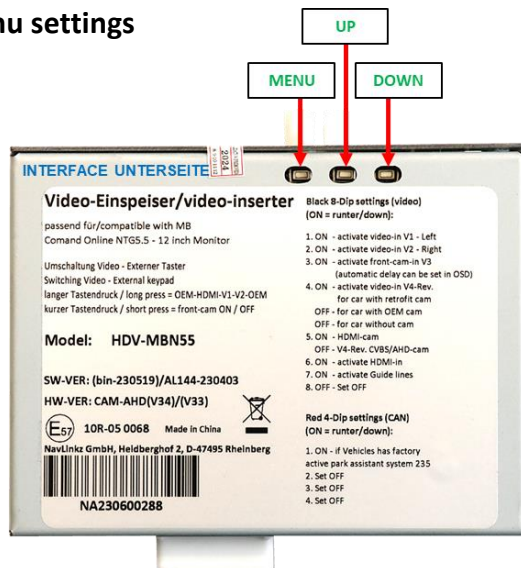

**Attention!**  
Video signal type of each video source must be preset in OSD-menu of corresponding video-input.

OSD-menu settings can be changed by using the 3 keys on rear-side of interface. Pressing MENU key opens the OSD-menu or moves cursor to next menu item. UP (UP) and DOWN (DOWN) change values of current menu item.



**The individual OSD-menu of every video input is only accessible when this input is displayed, regardless of whether a video-source is connected.**

The following setting options are available in the individual OSD-menus of the 5 video inputs:

#### Menu V1-Left (V2-Right)

8dip switch bench dip 1 (dip 2) = ON

**Input Source** Video-signal type for video-source(s) connected to **V1-Left (V2-Right)**. This setting **must** be preset for correct video playback. The following video-source signal types can be selected:  
CVBS video-sources: **NTSC, PAL**  
AHD video-sources: **720p NTSC, 960p NTSC, 1080p NTSC, 720p PAL, 960p PAL, 1080p PAL**

**Brightness** Brightness  
**Contrast** Contrast  
**Pos H** Horizontal image position  
**Pos V** Vertical image position  
**Trigger** Type of selection of video input **V1-Left (V2-Right)**

**"CAN" function for side cameras via CAN bus.** Selection of the video input **V1-Left (V2-Right)** when activating the blink signal left (right). The prerequisite is that the blink signal is recognised by the interface on the vehicle CAN bus. Manual selection of this input using an external keypad does not work with this setting.

**"Wire" function for other video sources or side cameras without CAN bus.** The video input **V1-Left (V2-Right)** is selected exclusively via the **light blue (dark blue) Trig-Left (Trig-Right)** wire or manually via an external keypad.

**Trig-Priority** Switching priority when switching signals are present for multiple inputs simultaneously (CAN bus or analogue +12 V triggers). The signal with the highest priority is displayed:

**L-R-Rear: V1-Left → V2-Right → V4-Reverse**  
**Rear-R-L: V4-Reverse → V2-Right → V1-Left**

Menu of V1-LEFT	
InputSource	720P NTSC
Brightness	50
Contrast	50
PosH	04
PosV	00
Trigger	Can
Trig-Priority	L-R-Rear

Menu of V2-RIGHT	
InputSource	720P NTSC
Brightness	50
Contrast	50
PosH	04
PosV	00
Trigger	Can
Trig-Priority	L-R-Rear

### Menu **V3 front**      Switch bench of 8 dip switches Dip 3 = ON

**Input Source**      Video-signal type for video-source(s) connected to **V3-Front**.  
 This setting **must** be preset for correct video playback.  
 The following video-source signal types can be selected:

CVBS video-sources:      **NTSC, PAL**  
 AHD video-sources:      **720p NTSC, 960p NTSC, 1080p NTSC, 720p PAL, 960p PAL, 1080p PAL**

**Brightness**      Brightness  
**Contrast**      Contrast  
**Pos H**      Horizontal image position  
**Pos V**      Vertical image position  
**Trigger**      Type of selection of video input **V3 front**.

**"Delay" function for front camera.** The **"Delay"** setting is used to determine the automatic switching of a front camera connected to the V3 **front input** after reverse gear is engaged and its display duration on the display. Available are 5s after REV, 10s after REV, 15s after REV, 20s after REV.

**"Wire" function for other video sources.** If another video source is to be connected to **V3-Front** instead of a front camera, select the **"Wire"** setting. This switches off the **"Delay"** function and the input can only be selected via the **white Trig-Front** wire or manually via an external keypad.

**Trig-Priority**      Switching priority when switching signals are present for multiple inputs simultaneously (CAN bus or analogue +12 V triggers). The signal with the highest priority is displayed:  
**L-R-Rear: V1-Left → V2-Right → V4-Reverse**  
**Rear-R-L: V4-Reverse → V2-Right → V1-Left**

Menu of V3-FRONT	
InputSource	720P NTSC
Brightness	50
Contrast	50
PosH	04
PosV	00
Trigger	10s after REV
Trig-Priority	L-R-Rear

### Menu **V4 reverse** Switch bench of 8 dip switches Dip 4 = ON, Dip 5 = OFF, Dip 6 = OFF

**V4-Reverse** input has no function if **HDMI input\*** is defined as rear-view camera input (Dip 5 = ON).

Menu of V4-REVERSE	
InputSource	720P NTSC
Brightness	50
Contrast	50
PosH	04
PosV	00
Trigger	Can
Trig-Priority	L-R-Rear
Guide-Type	Dynamic2
Guide-PosV	37
GuideL-PosH	48
GuideR-PosH	87
Maxim-CURVE	20
External SW	YES
Start-Delay	10s

**Input Source** Video-signal type for video-source(s) connected to **V4-Reverse**. This setting **must** be preset for correct video playback.

The following video-source signal types can be selected:

CVBS video-sources: **NTSC, PAL**

AHD video-sources: **720p NTSC, 960p NTSC, 1080p NTSC, 720p PAL, 960p PAL, 1080p PAL**

**Brightness** Brightness

**Contrast** Contrast

**Item H** Horizontal image position

**Item V** Vertical image position

**Trigger** Type of selection of rear-view camera input **V4 reverse**.

**"CAN" function with CAN bus connection.** With the "CAN" setting, the system automatically switches to **V4 reverse** for CVBS/AHD rear-view camera when reverse gear is engaged. The interface must recognise the reverse gear in the CAN bus.

**"Wire" function with analogue connection.** The selection of a rear-view camera connected to the **V4 reverse** via the **green Trig-Rear wire** is possible with both the "Wire" and "CAN" settings. **Switch bench of 8 dip switches Dip 4 = ON, Dip 5 = OFF, Dip 6 = OFF** connection.

**Trig-Priority** Switching priority when switching signals are present for multiple inputs simultaneously (CAN bus or analogue +12 V triggers). The signal with the highest priority is displayed:

**L-R-Rear: V1-Left → V2-Right → V4-Reverse**

**Rear-R-L: V4-Reverse → V2-Right → V1-Left**

**Guide Type** Setting 6 different angles of the guide lines for the rear-view camera

Moving guide lines **Dynamic 1-6**

Fixed guide lines **Fixed 1-6**

No guide lines **OFF**

**Guide Pos. V** Vertical position of the auxiliary wires **00-69**

**Guide L Pos.H** Horizontal position of the left auxiliary wire **00-90**

**Guide R Pos.H** Horizontal position of the right-hand auxiliary wire **00-121**

**Maxim. Curve** Radius of the auxiliary wires **01-20**

**External SW** Selectable via external keypad **V4 Reverse**

**YES: Factory video → HDMI\* → V1-Left → V2-Right → V4-Reverse → Factory video**

**NO: Factory video → HDMI\* → V1-Left → V2-Right → Factory video**

**Start-Delay** Switch delay of the interface at start-up. This function is technically necessary in some vehicles, as otherwise the factory system may malfunction (e.g. black screen, touch problems). The following options are available (in seconds):

**5s/6s/7s/8s/9s/10s/12s/15s/20s**

Changing the default settings may cause malfunctions!

\* **HDMI input only available with HDV-MBN55**

**Menu HDMI\*** Switch bench of 8 dip switches (dip 4 = ON, dip 5 = **ON/OFF**, dip 6 = ON)

### HDMI AV input (Dip 5 – OFF)

<b>InputSource</b>	The picture resolution of connected HDMI sources is detected automatically.
<b>Brightness</b>	Brightness
<b>Contrast</b>	Contrast
<b>Item H</b>	Horizontal image position
<b>Item V</b>	Vertical image position

Menu of HDMI	
InputSource	AutoDetect
Brightness	50
Contrast	50
PosH	04
PosV	00

### HDMI rear-view camera input (Dip 5 = ON)



<b>InputSource</b>	The picture resolution of connected HDMI sources is detected automatically.
<b>Brightness</b>	Brightness
<b>Contrast</b>	Contrast
<b>Pos. H</b>	Horizontal image position
<b>Pos. V</b>	Vertical image position
<b>Trigger</b>	Type of selection of rear-view camera input <b>HDMI-REV.</b>

Menu of HDMI-REVERSE	
InputSource	AutoDetect
Brightness	50
Contrast	50
PosH	04
PosV	00
Trigger	Can
Trig-Priority	L-R-Rear
Guide-Type	Dynamic2
Guide-PosV	37
GuideL-PosH	48
GuideR-PosH	87
Maxim-CURVE	20
External SW	YES
Start-Delay	10s

**"CAN" function with CAN bus connection.** With the "CAN" setting, the system automatically switches to **HDMI\*** for HDMI rear-view camera when reverse gear is engaged. The interface must recognise the reverse gear in the CAN bus.

**"Wire" function with analogue connection.** The selection of a rear-view camera connected to the **HDMI\*** via the **green Trig-Rear wire** is possible with both the "Wire" and "CAN" settings. It is recommended to set "Wire" for analogue (reversing signal) connection.

**Trig-Priority** Switching priority when switching signals are present for multiple inputs simultaneously (CAN bus or analogue +12 V triggers). The signal with the highest priority is displayed:

**L-R-Rear: V1-Left → V2-Right → V4-Reverse**  
**Rear-R-L: V4-Reverse → V2-Right → V1-Left**

**Guide Type** Setting 6 different angles of the guide lines for the rear-view camera

Moving guide lines	<b>Dynamic 1-6</b>
Fixed guide lines	<b>Fixed 1-6</b>
No guide lines	<b>OFF</b>

**Guide Pos. V** Vertical position of the guide lines **00-69**

**Guide L Pos.H** Horizontal position of the left hand guide line **00-90**

**Guide R Pos.H** Horizontal position of the right-hand guide line **00-90**

**Maxim. Curve** Radius of the guide lines **01-20**

**External SW** Selectable via external keypad **V4 Reverse**  
**YES: Factory video → HDMI\* → V1-Left → V2-Right → V4-Reverse → Factory video**  
**NO: Factory video → HDMI\* → V1-Left → V2-Right → Factory video**

**Start-Delay** Switch delay of the interface at start-up. This function is technically necessary in some vehicles, as otherwise the factory system may malfunction (e.g. black screen, touch problems). The following options are available (in seconds):

**5s/6s/7s/8s/9s/10s/12s/15s/20s**

Changing the default settings may cause malfunctions!



**Notes: V4-Reverse** input has no function if the **HDMI input\*** is defined as a rear-view camera input (dip 5 = **ON**).

\* **HDMI input only available with HDV-MBN55**

## 3 Interface operation

The external keypad of the can be used to switch all enabled inputs.

➤ Long press of keypad (2-3 seconds)

Long press of external keypad (2-3 seconds), switches from factory video to inserted first enabled interface video-input. Any additional long press switches to the next enabled interface video-input and after last back to factory video. Disabled inputs are skipped.

If all inputs are enabled by the corresponding dip-switches, the order is as follows:

- *Factory video* → **HDMI\*** → **V1-Left** → **V2-Right** → **V4-Reverse\*\*** → *Factory video*

\* **HDMI-input only available on HDV-MBN55**

\*\***V4-Reverse** can only be selected via the external keypad if the "External SW" function is set to "Yes" in the **V4-Reverse** menu.

➤ Short press of keypad (only if dip 3 is set to ON)

Short press of external keypad, switches from any video mode to front camera input **V3-Front** and next short press switches back to the previous video mode.



**Note:** We recommend to install the external keypad for possible support reasons even if not required for customer needs. Make sure the external keypad is not installed "pressed" then.

### 3.1 Optional: Operating the video interface via the 'HDA-RC' remote control

Instead of the external keypad, the interface can also be operated using the optionally available 'HDA-RC' remote control.\* This allows direct selection of the video/camera inputs and more convenient changing of settings in the respective OSD menus.

\* The remote control is compatible with all HDA and HDV interfaces that are labelled with 'RC' at the end of the software version.



Remote control 'HDA-RC'  
optionally available

## 4 Specifications

BATT/ACC range	9V - 16V
Stand-by power drain	about 4.5mA
Power consumption	355mA @12V
Video input	0.7V - 1V
Video input signal types	CVBS/AHD/ <b>HDMI (HDV-version only)</b>
Signal standards CVBS/AHD	NTSC/PAL
Temperature range	-40°C to +85°C
Dimensions video-box	117 x 25 x 109 mm (W x H x D)

## 5 FAQ - Troubleshooting interface functions - product-specific

Problem	Possible reasons	Solution
Vehicle battery discharges	Power connection made to battery terminal 30	See chapter 2.4 <i>Connection – harnesses, power supply and CAN-bus or analogue without CAN-bus</i> (Connection of 10pin power/CAN cable)
Distorted or no inserted video	Video-signal type of video-source not defined in OSD-menu of the corresponding video input	See chapter 2.12 <i>OSD-menu settings</i> - Menu of the respective input

## 6 FAQ - Troubleshooting Interface functions - general

For any troubles which may occur, check the following table for a solution before requesting support from your vendor.

Symptom	Possible reason	Possible solution
No picture/black picture (factory picture).	Not all connectors have been reconnected to factory head-unit or monitor after installation.	Connect missing connectors.
	CAN-bus wires connected to CAN-bus in wrong place.	Refer to the manual where to connect to the CAN-bus. If not mentioned, try another place to connect to the CAN-bus.
	No power on video-interface (all LED video-interface are off).	Check power connection of interface.
No picture/black picture/white picture (inserted picture) but factory picture is OK.	No picture from video source.	Check on other monitor whether video source is OK.
	No video-source connected to the selected interface input.	Check settings dips 1 to 5 of 8dip bench of video interface which inputs are enabled and switch to corresponding input(s).
	Setting of video signal type of active video input is not equal to video signal type of connected video-source.	Set the video signal type of the video source correctly in the OSD menu of the corresponding input.
	LVDS cables plugged in wrong place.	Double-check whether order of LVDS cables is exactly connected according to manual. Plugging into head-unit does not work when the manual says to plug into monitor and vice versa.
	Wrong settings of video-interface.	Verify the vehicle-specific dip switch position in the instructions. If necessary, test different positions of the vehicle-specific dip switches. Perform a power reset after each change (briefly remove the black 10-pin micro-fit power socket once).
Inserted picture totally wrong size or position.		Verify the vehicle-specific dip switch position in the instructions. If necessary, test different positions of the vehicle-specific dip switches. Perform a power reset after each change (briefly remove the black 10-pin micro-fit power socket once).
Inserted picture double or multiple times on monitor.		
Inserted picture distorted, flickering or running vertically.	Video sources output set to AUTO or MULTI which causes a conflict with the interfaces auto detection.	(Only concerns video-sources with selectable output – e.g., DVD-Players, TV-Tuners, etc.) Set video source output fixed to PAL or NTSC. It is best to set all video sources to the same video signal type output.
	If error occurs only after source switching: Connected sources are not set to same video signal type output.	Set all video sources to the same video signal type output.
	Setting of video signal type of active video input is not equal to video signal type of connected video-source.	Set the video signal type of the video source correctly in the OSD menu of the corresponding input.
Inserted picture b/w.	Setting of video signal type of active video input is not equal to video signal type of connected video-source.	Set the video signal type of the video source correctly in the OSD menu of the corresponding input.

Symptom	Possible reason	Possible solution
Only on first inserted video activation after IGN on, the inserted picture is distorted.	Menu item <i>Trigger</i> of the corresponding video-input is set to <i>CAN-bus</i> though analogue signal triggering is used.	Open OSD-menu of corresponding video input and set the menu item <i>Trigger</i> to <i>Wire</i> .
Inserted picture qual. bad.	Picture settings have not been adjusted.	Use the 3 switches on interface-box or optional HDA-RC cable remote control to set the desired picture settings for the respective video source in the OSD menu of the interface.
Inserted picture size slightly wrong.		
Inserted picture position wrong.		
Camera input picture flickers.	Camera is being tested under fluorescent light (neon).	Test camera under natural light outside the garage.
Camera input picture is bluish.	Protection sticker not removed from camera lens.	Remove protection sticker from lens.
Camera input picture black.	Camera power taken directly from reverse gear lamp.	Use relay or electronic filter to "clean" reverse gear lamp power. Alternatively, camera power can be taken from green wire CAM Power.
Camera input picture has distortion.		
Switching to inserted video does not work after IGN on or vehicle startup- temporary.	Interface has a start-up delay during which, after interface start-up for certain time, there is no switching to inserted video. Required to prevent the factory system from crashing.	In OSD menu of V4, default delay can be shortened time in menu item <i>StartDelay</i> , this might especially make sense on installations without connection to CAN-bus. Note: Too short <i>StartDelay</i> setting can cause (sporadically) black-screen of factory picture or loss of factory touch-screen control.
Not possible to switch video sources by OEM button.	Function not supported in this vehicle.	Use external keypad for AV-switching.
Not possible to switch video sources by external keypad.	Pressed too short.	For video source switching a longer press of about 2.5 seconds is required.
	Video-input is not enabled.	Enable corresponding inputs (dips 1 to 5 of 8dip bench).
Interface does not switch to reverse camera input when reverse gear is engaged or does not switch to side camera input(s) when turn signal in on.	CAN-bus of vehicle not fully compatible with interface. Function not supported.	Follow the manual for R-gear signal or turn signal from analogue signal.
	Menu item <i>trigger</i> in the OSD of the video-input was set to <i>Wire</i> .	Switch on corresponding input by external button or 12V to corresponding trigger input. Open OSD-menu of corresponding video input and set the menu item <i>Trigger</i> to <i>CAN bus</i> .
OSD-menu of interface cannot be accessed/opened.	No inserted video input of interface is active, factory picture is displayed.	Each video input of interface has its own OSD with its own settings. The OSD for each input can only be opened when the input is displayed.

## 7 Technical Support

Please note that direct technical support is only available for products purchased directly from NavLinkz GmbH. For products bought from other sources, contact your vendor for technical support.

**For any support requests make sure to at least prepare:**

- Product code and serial number of all involved products
- Vehicle data such brand, model, year of production, VIN, infotainment model

**NavLinkz GmbH**  
**Distribution/Tech dealer-support**  
Heidberghof 2  
D-47495 Rheinberg

Tel +49 2843 17595 00

Email [mail@navlinkz.de](mailto:mail@navlinkz.de)



10R-06 5485



Made in China

