

## Video-inserter RL1-MMI3G



examples

Compatible with  
**Audi** vehicles with  
MMI3G basic/high, MMI3G+ basic/high infotainments  
**VW** vehicles with  
RNS850 infotainment and 4pin HSD LVDS connector

Video-inserter for rear-view camera  
and two additional video sources

### Product features

- Video-inserter for factory-infotainment systems
- 2 CVBS video-inputs for after-market devices (e.g. DVD-Player, DVB-T tuner)
- CVBS Rear-view camera video-input
- Automatic switching to rear-view camera input on engagement of reverse gear
- Video-in-motion (ONLY for connected video-sources)
- Video-inputs NTSC compatible

**ATTENTION!** The interface is installed  
on the backside of the head-unit,  
not on the monitor!!!

## Contents

- 1. Prior to installation**
  - 1.1. ...Delivery contents
  - 1.2. Checking the compatibility of vehicle and accessories
  - 1.3. Connectors – video interface
  - 1.4. Dip-switch settings – video interface
    - 1.4.1. ... Enabling the interface's video inputs (dip 2-3)
    - 1.4.2. Rear-view camera setting (dip 5)
    - 1.4.3. Monitor selection (dip 7-8)
  
- 2. Installation**
  - 2.1. Place of connection
  - 2.2. Connection schema
  - 2.3. Connection – 6pin interface cable
  - 2.4. Connection – picture signal cable
  - 2.5. Connection – video sources'
    - 2.5.1. After-market rear-view camera
  - 2.6. Audio insertion
  - 2.7. Connection - external keypad
  - 2.8. Picture settings
  
- 3. Switching video sources**
  
- 4. Specifications video-interface**
  
- 5. Frequently asked questions**
  
- 6. Technical support**

## Legal Information

By law, watching moving pictures while driving is prohibited, the driver must not be distracted. We do not accept any liability for material damage or personal injury resulting, directly or indirectly, from installation or operation of this product. This product should only be used while standing or to display fixed menus or rear-view-camera video when the vehicle is moving, for example the MP3 menu for DVD upgrades.

Changes/updates of the vehicle's software can cause malfunctions of the interface. If available, we offer free software-updates for our interfaces for one year after purchase. To receive a free update, the interface must be sent in at own cost. Labor cost for and other expenses involved with the software-updates will not be refunded.

## 1. Prior to installation

Read the manual prior to installation.

Technical knowledge is necessary for installation. The place of installation must be free of moisture and away from heat sources.

### 1.1. Delivery contents

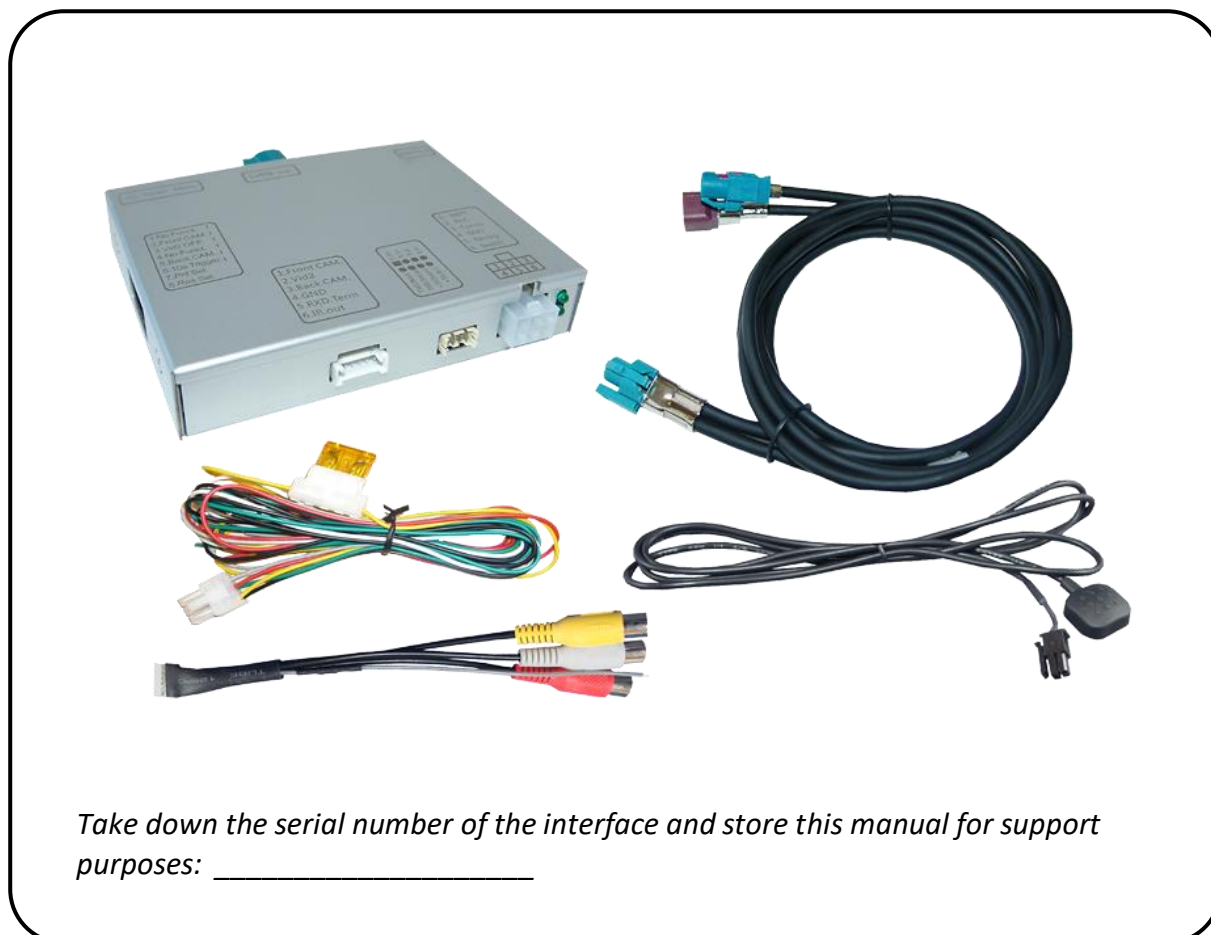

## 1.2. Checking the compatibility of vehicle and accessories

Requirements		
Brand	Vehicles	Infotainment
Audi	<b>A1 (8X)</b> since 05/2010 til 10/2018 <b>A4 (8K)</b> since 05/2009 til 08/2015 <b>A5 (8T)</b> since 11/2008 til 06/2016 <b>A6 (4F)</b> since 08/2008 til 03/2011 <b>A6 (4G)</b> since 04/2011 til 09/2014 <b>A7 (4G)</b> since 07/2010 til 05/2014 <b>A8 (4E)</b> since 09/2008 til 03/2010 <b>A8 (4H)</b> since 03/2010 til 10/2017 <b>Q3 (8U)</b> 10/2011 – 07/2018 <b>Q5 (8R)</b> since 11/2008 til 2017 <b>Q7 (4L)</b> since 05/2009 til 03/2015	<b>MMI Navigation (Plus)</b> - MMI3G+, MMI3G High, MMI3G Basic – 7inch or 8inch monitor
	<b>A1 (8X)</b> since 05/2010 <b>A6 (4F)</b> since 08/2008 til 03/2011 <b>A6 (4G)</b> since 04/2011 til 05/2018 <b>A7 (4G)</b> since 07/2010 til 01/2018 <b>Q3 (8U)</b> 10/2011 – 07/2018 <b>Q7 (4L)</b> since 05/2009 til 03/2015	<b>MMI Radio/MMI Radio Plus/MMI Navigation -</b> RMC/RMC_Cnct_Plus/ RMC_Cnct_Nav – 6.5inch monitor
VW	<b>Touareg (7P)</b> since model year 2011 til 06/2018	<b>RNS850</b>
<b>Limitations</b>		
<i>Video only</i>	The interface inserts <b>ONLY</b> video into the infotainment. For sound use the possibly existing factory-audio-AUX-input, a FM-modulator or the AUX-in interface AUX-110.	
<i>Factory OPS</i>	Display of an optical park display (OPS) isn't possible if an after-market rear-view camera is connected and reverse gear is engaged. Acoustic signals are still existing.	
<i>Factory rear-view camera</i>	Automatic switch-back from inserted video to factory rear-view camera only while reverse gear is engaged. To delay the switch-back time, additional electronics is required.	
<i>Video input signal</i>	NTSC video sources compatible only.	

## 1.3. Connectors - Video-interface

The video-interface converts the video signals of connected after-market sources in a factory monitor compatible picture signal which is inserted in the factory monitor, by using separate trigger options. Further it reads the vehicle's digital signals out of the vehicle's CAN-bus and converts them for the video interface.

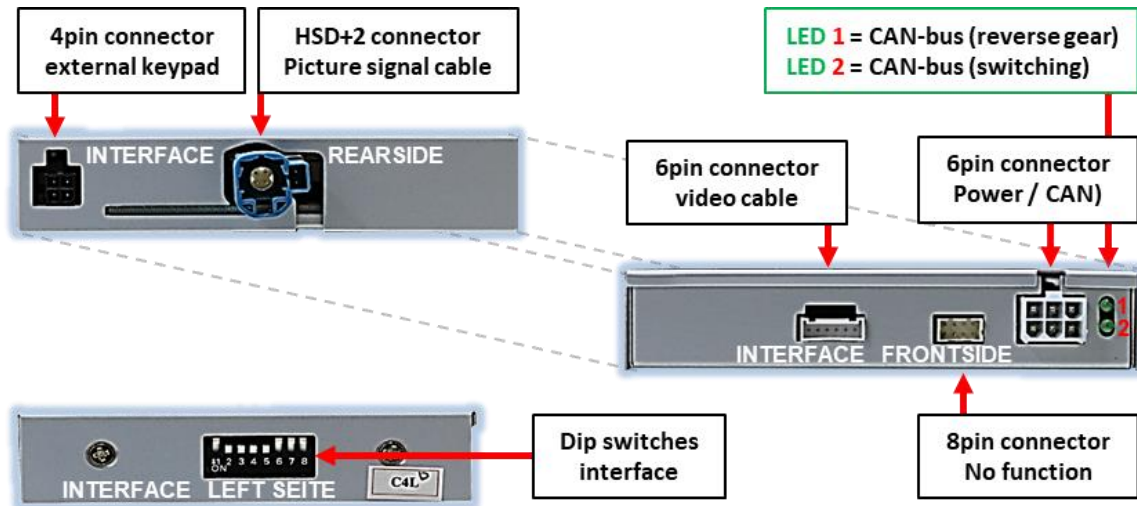

## 1.4. Dip-switch settings - video interface

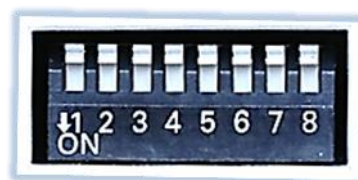

Some settings must be selected by the dip-switches on the video interface. Dip position down is ON and position up is OFF.

Dip	Function	ON (down)	OFF (up)
1	No function	-	set to OFF
2	CVBS AV1-input	enabled	disabled
3	CVBS AV2-input	enabled	disabled
4	No function	-	set to OFF
5	Rear-view cam type	after-market	factory or none
6	No function		set to OFF
7	Monitor specific adjustments	Try all possible combinations of Dips 7 and 8 to receive the best picture (quality and size)	
8			

See following chapters for detailed information.

### 1.4.1. Enabling the interface's video inputs (dip 2-3)

Only the enabled video inputs can be accessed when switching through the interface's video sources. It is recommended to enable only the required inputs for the disabled will be skipped when switching through the video interfaces inputs.

### 1.4.2. Rear-view camera setting (dip 5)

If set to OFF, the interface switches to factory LVDS picture while the reverse gear is engaged to display factory rear-view camera or factory optical park system picture.

If set to ON, the interface switches to its rear-view camera input CAM while the reverse gear is engaged.

### 1.4.3. Monitor selection (dip 7-8)

Dips 7 and 8 customize the monitor-specific video settings which sometimes even vary within head units of the same version, caused by different monitor specifications. It is necessary to try all possible combinations of both dials while a working video source is connected to the chosen input of the interface. One of the combinations will show the best picture size and quality (some may give no picture, black picture, flickering picture, wrong picture size). It is possible to first hot plug through the dip combinations. If there is no visible change of picture after trying all options, retry and disconnect the 6pin plug of the video interface between every change of the dip setting.

Dip 1, 4 and 6 are out of function and have to be set to OFF.

**After each Dip-switch-change a power-reset of the Video Interface has to be performed!**

## 2. Installation

To install the interface, first switch off the ignition and disconnect the vehicle's battery. Please read the owner's manual of the car, regarding the battery's disconnection! If required, enable the car's Sleep-mode (hibernation mode)  
In case the sleep-mode does not succeed, the disconnection of the battery can be done with a resistor lead.

As with any installation of retrofit equipment, a stand-by test is necessary after the installation of the video interface, to ensure that the unit also switches off after reaching the vehicle's sleep mode.

Before the final installation, we recommend a test-run of the interface. Due to changes in the production of the vehicle manufacturer, there's always the possibility of incompatibility.

### 2.1. Place of connection

The interface has to be connected on the rear-side of the head-unit (navigation computer/radio) which is in most vehicles located either in the glove-box or in the middle console, the *classic* radio position.

## 2.2. Connection scheme

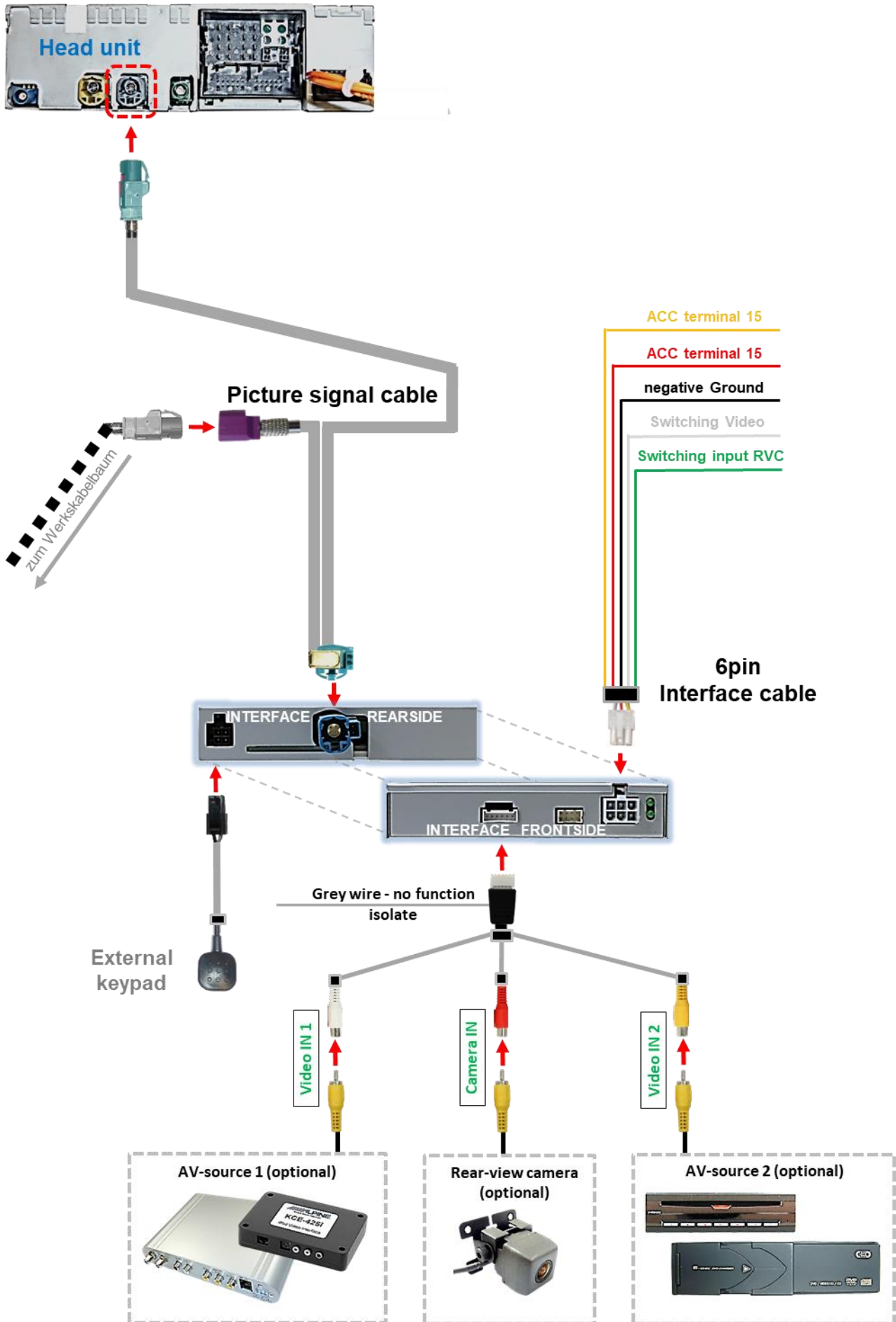

## 2.3. Connection - 6pin interface cable

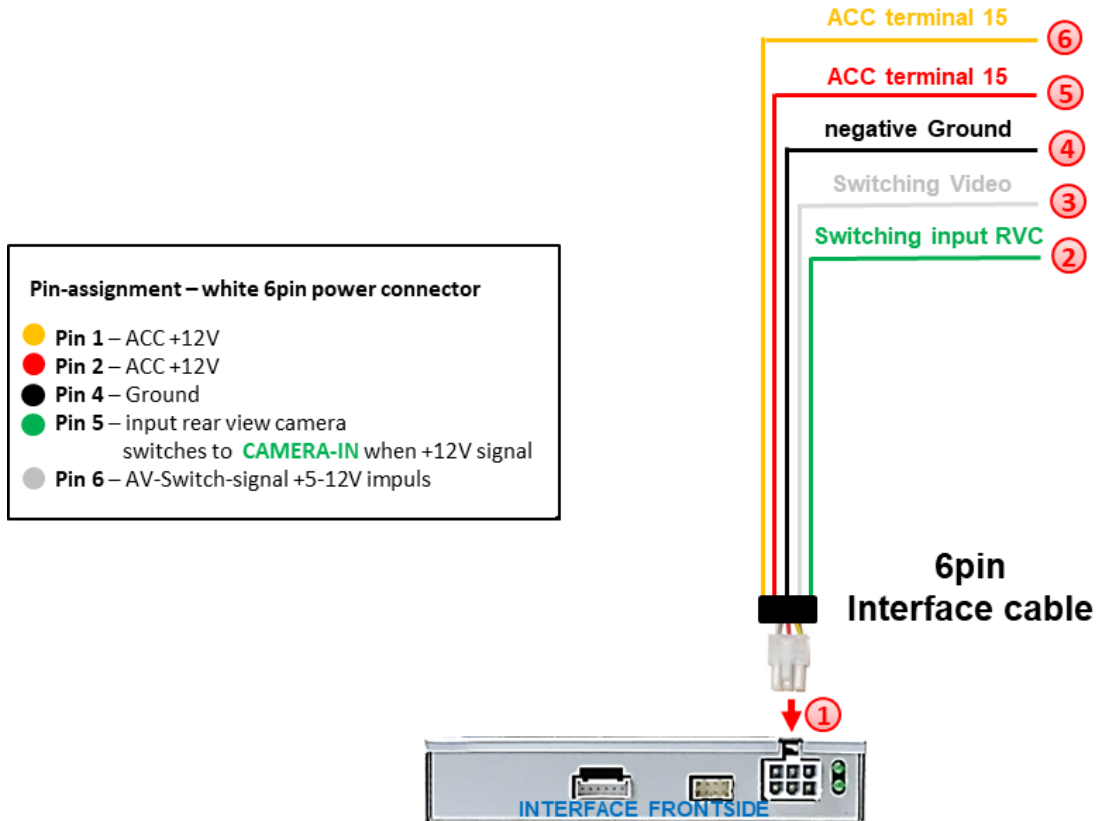

- ❶ Connect the white female 6pin connector of the 6pin interface cable to the male 6pin connector of the video interface.
- ❷ Connect the green wire of the 6pin interface cable to +12V of the reverse gear signal. (e.g. reversing light).
- ❸ If desired, the white wire of the 6pin interface cable can be used alternatively to the external button to switch the video sources (12V pulse for 2-3 seconds).
- ❹ Connect the black wire of the 6pin interface cable to vehicle ground.
- ❺ Connect the red wire of the 6pin interface cable to +12V ACC terminal 15.
- ❻ Connect the yellow wire of the 6pin interface cable to +12V ACC terminal 15.

**Note:** The connection of the green wire (Reverse signal) will be described in chapter “After-market rear-view camera”. The white wire, can be used by +12V impulse to switch the enabled video sources , same as the keypad (see chapter “video interface-operation”).



## 2.5. Connection – video sources

It is possible to connect 2 after-market Video-sources and 1 after-market rear-view camera to the video-interface.

**Before final installation of the peripheral devices, we recommend a test-run of the interface. Due to changes in the production of the vehicle manufacturer is always the possibility of incompatibility.**

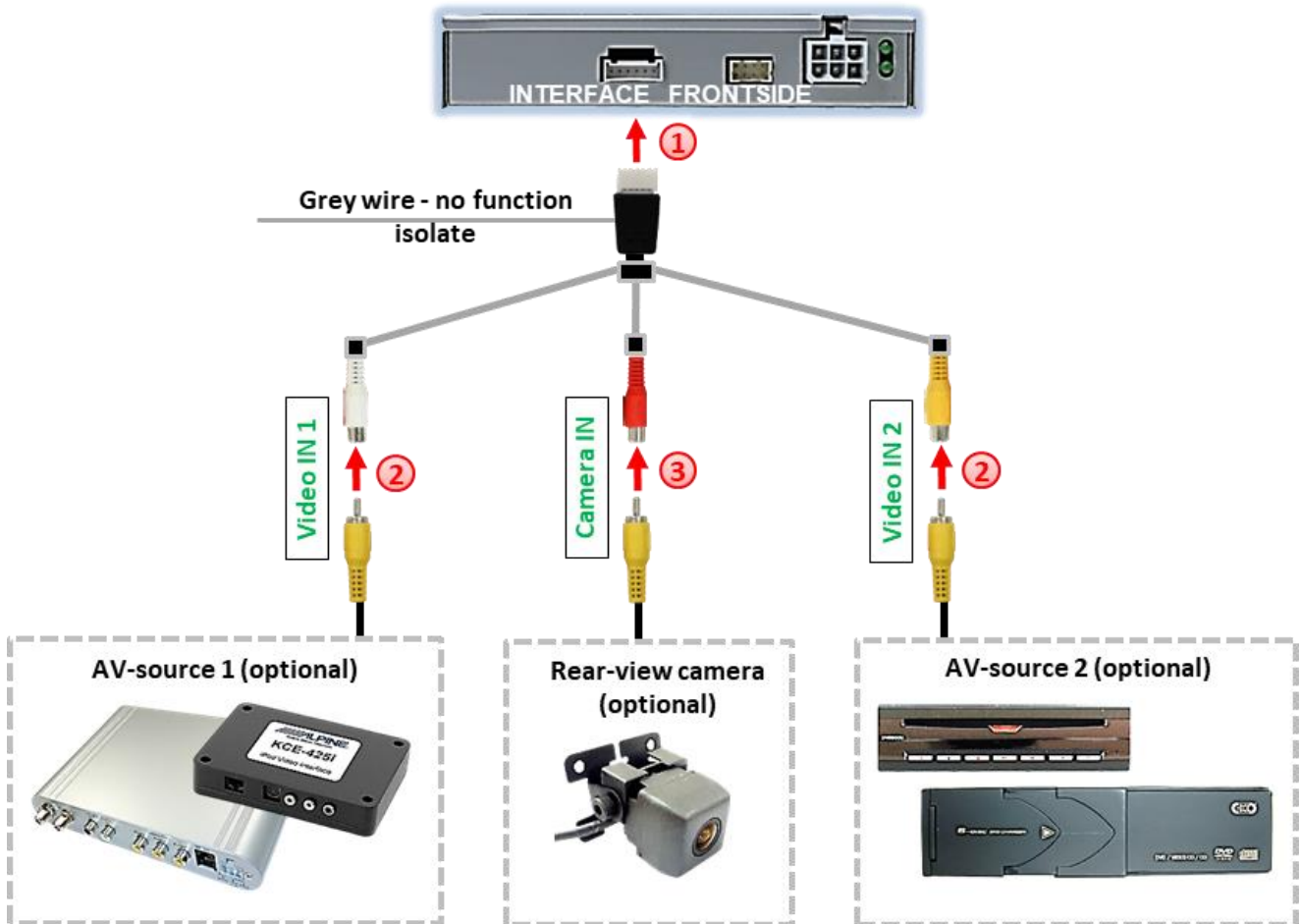

- ① Connect the female 6pin connector of the video cable to the male 6pin connector of the video-interface.
- ② Connect the video RCA of the video source 1 and 2 to the female RCA connector "Video IN1" and "Video IN 2" of the 6pin video cable.
- ③ Connect the video RCA of the rear-view camera to the female RCA connector "Camera IN" of the 6pin video cable.

## 2.5.1. After-market rear-view camera

**Note:** Do not forget to set dip5 of video-interface to **ON** before testing.

To switch to the rear-view camera when reverse gear is engaged, an external switching signal from the reverse gear light is required. As the reverse gear light signal contains electronic interference, a traditional open relay (e.g AC-RW-1230 with wiring AC-RS5) or filter (e.g. AC-PNF-RVC) is required. Below schema shows the use of a relay (normally open).

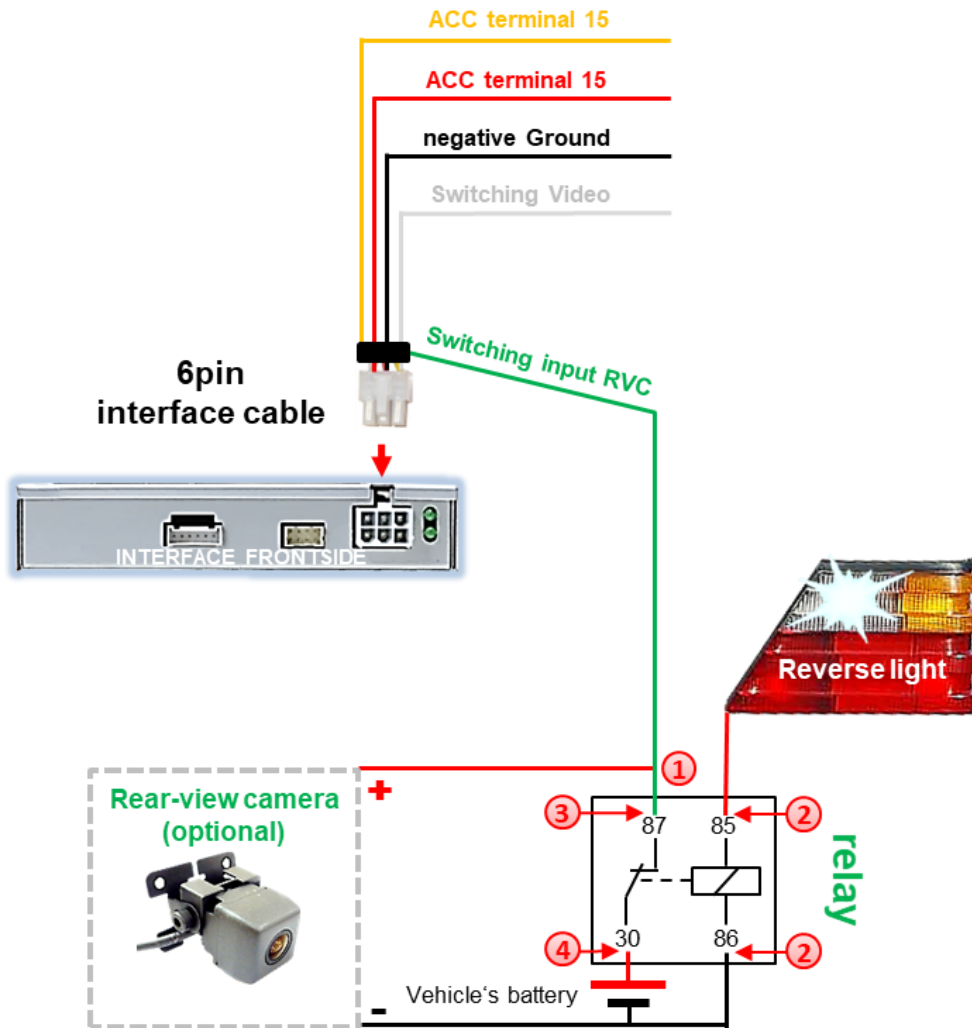

- ① Connect the green **switching input cable** to the output connector (87) of the relay.
- ② Connect the Reverse light's power-cable to coil (85) and the vehicle's ground to coil (86) of the relay.
- ③ Connect the output connector (87) of the relay to the rear-view camera's power-cable, like you did it to the green **switching input cable** before.
- ④ Connect stabile and permanent +12V to the relay's input connector (30).

## 2.6. Audio insertion

This interface can only insert video signals into the factory infotainment. Audio insertion must be done by factory audio AUX input, the optionally available AUX-in interface AUX-110 (only for MMI3G, not for MMI3G+) or FM-modulator. The inserted video-signal can be activated simultaneously to each audio-mode of the factory infotainment.

If 2 AV sources shall be connected to the infotainment, additional electronic is necessary to switch the audio signals.

## 2.7. Connecting - external keypad

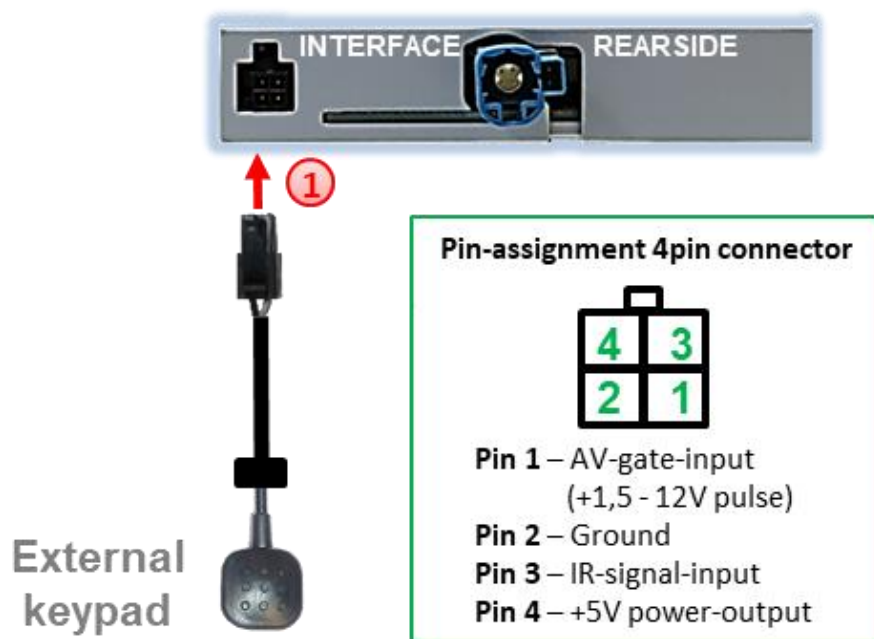

- 1 Connect the female 4pin connector of the keypad to the male 4pin connector of the video-interface.

**Note:** Regardless if it'll be used or not, the external keypad should always be connected! In case of non-using, it should be invisibly hidden together with the video interface.

## 2.8. Picture settings

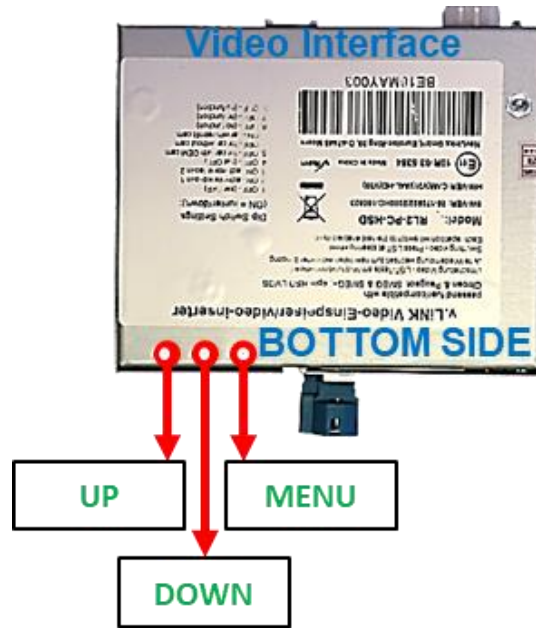

The picture settings are adjusted by the 3 buttons on the video-interface. Press the MENU button to open the OSD settings menu or to switch to the next menu item. Press UP and DOWN will change the selected value. The buttons are embedded in the housing to avoid accidental changes during or after installation. Picture settings must be done separately for AV1 and AV2 while the corresponding input is selected and visible on the monitor. The rear-view camera settings conceivably have to be done in AV 2.

**Note:** The OSD menu is only shown when a working video source is connected to the selected video-input of the interface.

The following settings are available:

- Contrast
- Brightness
- Saturation
- Position H (horizontal picture position)
- Position V (vertical picture position)

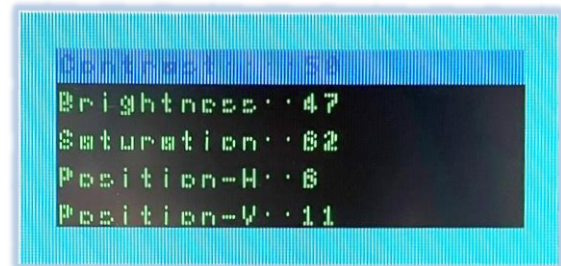

**Note:** To adjust the reverse picture, engage the reverse gear.

### 3. Switching video sources

Press the interface's external keypad to switch the video source. Each repetition will switch to the next enabled input. If all inputs are enabled the order is:

*Factory video → video IN1 → video IN2 → factory video →*

Disabled inputs will be skipped.

Alternatively the white wire of the 6pin cable can be used with a +5-12V pulse to switch the video-sources.

**Note:** Even if the switching through several video sources by the keypad mightn't be required, the keypad's invisible connection and availability is strongly recommended.

### 4. Specifications video-interface

BATT/ACC range	7V - 25V
Stand-by power drain	4mA
Power	195mA
Video input	0.7V - 1V
Video input formats	NTSC
Temperature range	-40°C to +85°C
Dimensions video-box (W x H x D)	113 x 25 x 115mm

## 4. FAQ – Trouble shooting Interface functions

For any troubles which may occur, check the following table for a solution before requesting support from your vendor.

Symptom	Reason	Possible solution
No picture/black picture (factory picture).	Not all connectors have been reconnected to factory head-unit or monitor after installation.	Connect missing connectors.
	No power on CAN-bus box (all LED CAN-bus box are off).	Check power supply of CAN-bus box. Check CAN-bus connection of CAN-bus box.
	CAN-bus box connected to CAN-bus in wrong place.	Refer to the manual where to connected to the CAN-bus. If not mentioned, try another place to connect to the CAN-bus.
	No power on video-interface (all LED video-interface are off).	Check whether CAN-bus box delivers +12V ACC on red wire output of 8pin to 6pin cable. If not cut wire and supply ACC +12V directly to video-interface.
No picture/black picture/white picture (inserted picture) but factory picture is OK.	No picture from video source.	Check on other monitor whether video source is OK.
	No video-source connected to the selected interface input.	Check settings dips 1 to 3 of video interface which inputs are activated and switch to corresponding input(s).
	LVDS cables plugged in wrong place.	Double-check whether order of LVDS cables is exactly connected according to manual. Plugging into head-unit does not work when the manual says to plug into monitor and vice versa.
Inserted picture totally wrong size or position.	Wrong monitor settings of video-interface.	Try different combinations of dips 7 and 8 of video-interface. Unplug 6pin power after each change.
Inserted picture double or 4 times on monitor.		
Inserted picture distorted, flickering or running vertically.	Video sources output set to AUTO or MULTI which causes a conflict with the interfaces auto detection.	Set video source output fixed to PAL or NTSC. It is best to set all video sources to the same standard.
	If error occurs only after source switching: Connected sources are not set to the same TV standard.	Set all video sources to the same standard.
	Some interfaces can only handle NTSC input.	Check manual whether there is a limitation to NTSC mentioned. If yes, set source fixed to NTSC output.
Inserted picture b/w.	Picture settings have not been adjusted.	Use the 3 buttons and the interface's OSD to adjust the picture settings for the corresponding video input.
Inserted picture qual. bad.		
Inserted picture size slightly wrong.		
Inserted picture position wrong.		
Camera input picture flickers.	Camera is being tested under fluorescent light which shines directly into the camera.	Test camera under natural light outside the garage.
Camera input picture is bluish.	Protection sticker not removed from camera lens.	Remove protection sticker from lens.

Symptom	Reason	Possible solution
Camera input picture black.	Camera power taken directly from reverse gear lamp.	Use relay or electronics to "clean" reverse gear lamp power. Alternatively, if CAN-bus box is compatible with the vehicle, camera power can be taken from green wire of 6pin to 8pin cable.
Camera input picture has distortion.		
Camera input picture settings cannot be adjusted.	Camera input picture settings can only be adjusted in AV2 mode.	Set dip 3 of video-interface to ON (if not input AV2 is not already activated) and connect the camera to AV2. Switch to AV2 and adjust settings. Reconnect camera to camera input and deactivate AV2 if not used for other source.
Graphics of a car in camera input picture.	Function PDC is ON in the interface OSD.	In compatible vehicles, the graphics will display the factory PDC distance. If not working or not wanted, set interface OSD menu item UI-CNTRL to ALLOFF.
Chinese signs in camera input picture	Function RET or ALL is ON (function for Asian market) in the interface OSD.	Set interface OSD menu item UI-CNTRL to ALLOFF or PDCON.
Not possible to switch video sources by OEM button.	CAN-bus interface does not support this function for vehicle.	Use external keypad or cut white wire of 6pin to 8pin cable and apply +12V impulses for AV-switching.
Not possible to switch video sources by external keypad.	Pressed too short.	For video source switching a longer press of about 2.5 seconds is required.
	SW-version of interface does not support external keypad.	Use OEM-button or cut white wire of 6pin to 8pin cable and apply +12V impulses for AV-switching.
Interface does not switch to camera input when reverse gear is engaged.	CAN-bus interface does not support this function for the vehicles.	Cut the green wire of the 6pin to 8pin cable and apply +12V constant from reverse gear-lamp signal. Use relay to "clean" R-gear lamp power.
Interface switches video-sources by itself.	CAN-bus interface compatibility to vehicle is limited.	Cut the grey wire of 6pin to 8pin and isolate both ends. If problem still occurs, additionally cut the white wire of 6pin to 8pin cable and isolate both ends.

## 5. Technical Support

Please note that direct technical support is only available for products purchased directly from NavLinkz GmbH. For products bought from other sources, contact your vendor for technical support.

**NavLinkz GmbH**  
**distribution/tech dealer-support**  
 Heidberghof 2  
 D-47495 Rheinberg

Tel +49 2843 17595 00  
 Email mail@navlinkz.de

 10R-03 5384

Made in China

