

Video-inserter RL4-NAC08

Attention!
Do not connect to vehicle monitor
damage to hardware!



**Compatible with
Opel, Citroen, Peugeot and Toyota vehicles
with NAC or RCC infotainment
and 7inch or 8inch monitor**

**Video-inserter for front- and rear-view camera
and two additional video inputs**

Product features

- Video-inserter for factory-infotainment systems
- 1 CVBS Input for rear-view camera
- 1 CVBS Input for front camera
- 2 CVBS video-inputs for after-market devices (e.g. USB-Player, DVB-T2 tuner)
- Automatic switching to rear-view camera input on engagement of the reverse gear
- Automatic front camera switching after reverse gear for 10 seconds
- Activatable parking guide lines for the rear-view camera (not available for all vehicles)
- Activatable PDC (not available for all vehicles)
- Video-in-motion (ONLY for connected video-sources)
- Video-inputs NTSC compatible

Attention!
Only for vehicles with
7inch or 8inch monitors.
For larger monitors use
HDA-NAC12 or HDV-NAC12

Contents

1. Prior to installation

- 1.1. Delivery contents
- 1.2. Checking the compatibility of vehicle and accessories
- 1.3. Warning notes
- 1.4. Connection Video-Interface
- 1.5. Settings of the 8 Dip switches (black)
 - 1.5.1. Adjustment – power supply output (dip 1)
 - 1.5.2. Enabling the interface's video inputs (dip 2-3)
 - 1.5.3. Rear-view camera setting (dip 5)
 - 1.5.4. Activating – front camera back switching (dip 6)
 - 1.5.5. Choosing the corresponding head unit version (dip 8)
- 1.6. Settings of the 4 Dip switches (CAN function – red)

2. Installation

- 2.1. Place of installation – video interface
- 2.2. Connection schema
- 2.3. Connection - head-unit
 - 2.3.1. Connection – picture signal cable
 - 2.3.1.1. Low version head unit (1 x 4 PIN HSD)
 - 2.3.1.2. High version head unit (2 x 4 PIN HSD)
 - 2.3.2. Connection– Power / CAN
 - 2.3.3. Installation with analogue connection (without CAN-Bus)
- 2.4. Power supply output
- 2.5. Connection - video sources
 - 2.5.1. Audio insertion
 - 2.5.2. After-market front camera
 - 2.5.3. After-market rear-view camera
 - 2.5.3.1. Case 1: Video-interface receives the reverse gear signal
 - 2.5.3.2. Case 2: Video interface does not receive the reverse gear signal
- 2.6. Connection - external keypad
- 2.7. Picture settings and guide lines

3. Interface operation

- 3.1. By NAVI button
- 3.2. By external keypad

4. Specifications

5. FAQ – Trouble shooting

6. Technical support

Legal Information

By law, watching moving pictures while driving is prohibited, the driver must not be distracted. We do not accept any liability for material damage or personal injury resulting, directly or indirectly, from installation or operation of this product. Apart from using this product in an unmoved vehicle, it should only be used to display fixed menus or rear-view-camera video when the vehicle is moving (for example the MP3 menu for DVD upgrades).

Changes/updates of the vehicle's software can cause malfunctions of the interface. Up to one year after purchase we offer free software-updates for our interfaces. To receive a free update, the interface has to be sent in at own cost. Wages for de-and reinstallation and other expenditures involved with the software-updates will not be refunded.

1. Prior to installation

Read the manual prior to installation. Technical knowledge is necessary for installation. The place of installation must be free of moisture and away from heat sources.

1.1. Delivery contents

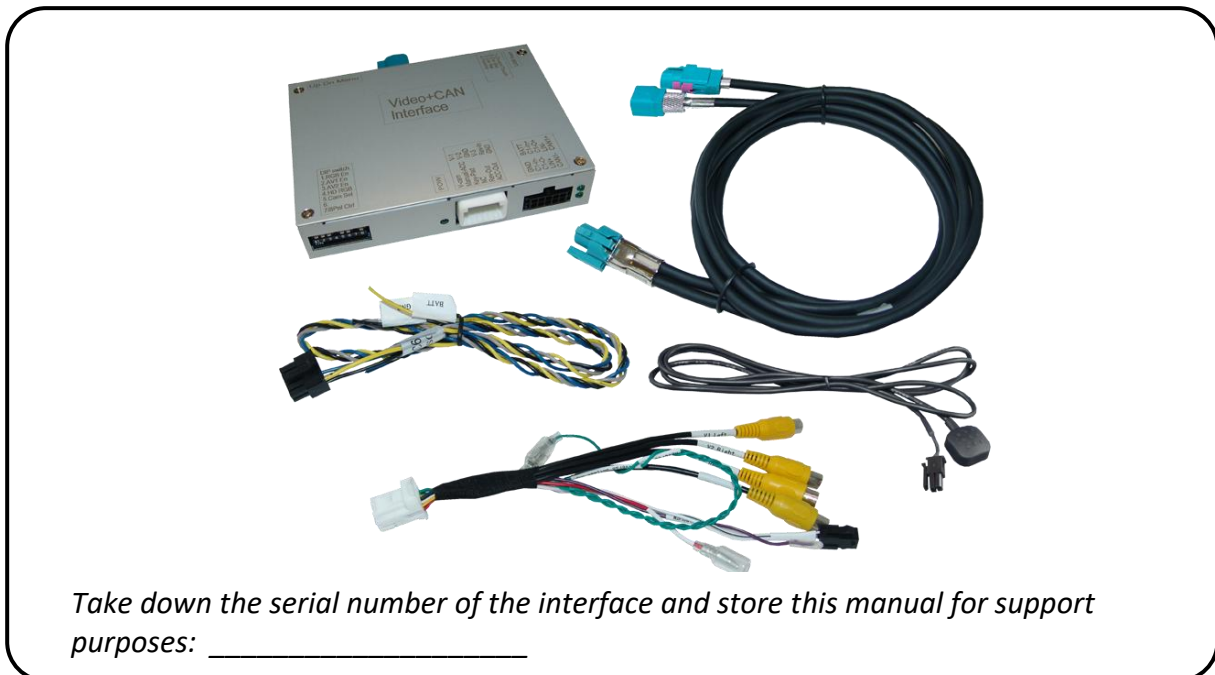

Attention!
Only for vehicles with
7inch or 8inch monitors.
For larger monitors use
HDA-NAC12 or HDV-NAC12

1.2. Checking the compatibility of vehicle and accessories

Compatibility		
Brand	Compatible vehicles	Infotainment systems
Citroen	Berlingo 3 (K9) from 09/2018 to 03/2024 C3 3rd gen. from 01/2017 to 04/2024 C3 Aircross from 11/2017 C4 Cactus II from 01/2018 to 09/2020 C4 (N) from approx. 2017 to 05/2018, Grand (C4), SpaceTourer from 06/2018 C4 Picasso from model year 2017 C4 X from 10/2022 C5 Aircross from 12/2018 Dispatch from model year 2016, Jumpy from model year 2016	NAC or RCC with 7inch or 8inch touch monitor. Continental or Bosch head-unit For Continental High version an additional cable CAB-HSD-MF026 might be required
Fiat	Doblo III (K9) as from 06/2022 Scudo III from 2021 Ulysse III from 03/2022	RCC (Bosch)
Opel	Combo E from 11/2018 to 11/2023 Corsa F from 07/2019 Crossland X from model year 2017 Grandland X from model year 2017 Mokka B from 09/2020 Vivaro C from 03/2019 Zafira Life from 03/2019	Navi 5.0 IntelliLink 8inch (NAC low Continental), Multimedia Radio 7inch (RCC Bosch), Multimedia Navi Pro 7inch, Multimedia 8inch
Peugeot	208 from 02/2017 to 03/2019 208 II from 06/2019 2008 from 02/2017 to 06/2019 2008 II from 11/2019 308 II from 07/2017 to 06/2021 3008 II from 10/2016 to 03/2024 508 from 02/2017 to 08/2018 508 II from 10/2018 5008 II from 02/2017 Expert III from 03/2016 Partner III from 06/2018 Rifter from 09/2018 to 03/2024 Traveller from 09/2016 to 04/2024	NAC or RCC with 7inch or 8inch touch monitor. Continental or Bosch head-unit For Continental High version an additional cable CAB-HSD-MF026 might be required
Toyota	ProAce from model year 2016 ProAce City from 04/2020	RCC (Bosch)

Limitations

<i>Video only</i>	The interface inserts ONLY video signals into the infotainment. For audio inserting, use the possibly existing factory audio-AUX-input or a FM-modulator. If 2 AV-sources shall be connected to the infotainment, for audio switching an additional electronic part is required.
<i>Factory rear-view camera</i>	Automatic switching-back from inserted video to factory rear-view camera is only possible while the reverse gear is engaged. To delay the switch-back, an additional electronic part is required.
<i>After market front camera</i>	The front camera will automatically be switched for 10 seconds after disengaging the reverse gear. A manually front camera switching is possible by external keypad.
<i>Video input signal</i>	NTSC video sources compatible only.
<i>NAC high-version</i>	If the two HSD connectors cannot be separated for the reconnection of the white HSD socket, the separately available cable CAB-HSD-MF026 can optionally be connected here.
<i>Guidelines and PDC</i>	Displayed guidelines and the optical PDC are not available in all vehicles.

1.3. Warning notes:

Damage to the head-unit is possible, if this RL4-NAC08 interface is installed to older Citroen / Peugeot SMEG or SMEG+ head-units (by Magneti Marelli)! Use this RL4-NAC08 interface only on Citroen/Opel/Peugeot/Toyota head-units NAC (by Continental) or RCC (Bosch). Designs and features – see the following pictures:



NAC-Systems



Furthermore, even when installed to the correct NAC systems, there is also **damage** to the head-unit possible if:

- the 4pin HSD connectors of this harness are wrong-plugged
- the 4pin HSD harness is connected to the vehicle monitor

Attention!
Do not connect to vehicle monitor
damage to hardware!

Prior to installation, the head-unit's version has to be determined (see following page).

1.4. Checking the head unit's version

Prior to installation, it has to be determined if whether the head-units version is a

low version head-unit

(single black male 4pin

HSD on backside)



Attention: Bosch Low Version requires different Dip 8 switch position (see following chapters)

OR

high version head-unit

(double black male 4pin

HSD on the backside)



Please, carefully follow the manual for high or low version connection of the head-unit. The monitor resolution (dip 8) is independent of the version of the head-unit. A low-version head-unit can also have the high resolution.

1.5. Connectors - Video-Interface

The video-interface converts the video signals of connected after-market sources in a factory monitor compatible picture signal which is inserted in the factory monitor, by using separate trigger options. Further it reads the vehicle's digital signals out of the vehicle's CAN-bus and converts them for the video interface.

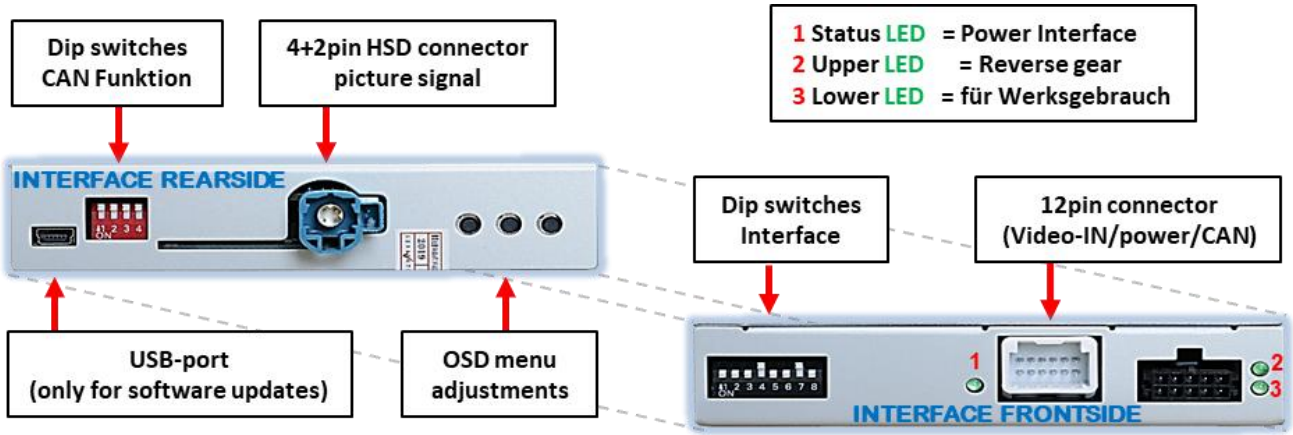

1.6. Settings of the 8 Dip switches (black)

Some settings have to be selected by the 8 dip-switches at the video-interface. Dip position down is ON and position up is OFF.

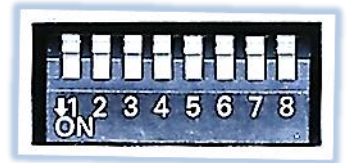

Dip	Function	ON (down)	OFF (up)
1	Front camera	enabled	disabled
	Power supply output (red wire)	+12V (max. 3A) when reverse gear is engaged incl. 10 seconds delay and +12V by manual switching to front camera by keypad	+12V (max. 3A) ACC
2	CVBS AV1-input	enabled	disabled
3	CVBS AV2-input	enabled	disabled
4	No function		Set to OFF
5	Rear-view cam type	after-market	factory or none
6	Frontcam back-switching for 10 seconds	enabled*	disabled
7	No function		Set to OFF
8	Monitor type	Low resolution monitor	High resolution monitor
		If you do not know the resolution, test both settings. Power reset after change of dip switches necessary.	

*The front camera will automatically be switched for 10 seconds after disengaging the reverse gear.
See the following chapters for detailed information.

1.6.1. Adjustment – power supply output (dip 1)

If set to **ON**, the video interfaces' red wire will supply +12V (max 3A) with engaging the reverse gear and additionally 10 more seconds delay for the time of the front camera's back-switching after the reverse gear has been disengaged. Furthermore, the red wire's power supply for the front cam becomes active with manually front camera switching (short press of the external keypad).

If set to **OFF**, the video interfaces' red wire will supply permanent +12V ACC (max 3A).

Description of the power supply output: see chapter "Power supply output".

1.6.2. Enabling the interface's video inputs (dip 2-3)

Only the enabled video inputs can be accessed by switching through the interface's video sources. It is recommended to enable only the required inputs. Then the disabled inputs will be skipped while switching through the video interfaces inputs.

1.6.3. Rear-view camera settings (dip 5)

If set to **OFF**, the interface switches to factory picture while the reverse gear is engaged to display factory rear-view camera or factory optical park system picture.

If set to **ON**, the interface switches to its rear-view camera input while the reverse gear is engaged.

1.6.4. Activating – front camera back-switching (dip 6)

If set to **ON**, the interface switches for 10 seconds from the rear-view camera to the front camera input after having disengaged the reverse gear. In addition, a manual switch-over to the front camera input is possible via keypad (short press) from any image mode.

(Attend to correct adjustment of the power supply output (dip1)!

1.6.5. Head unit selection (Dip 8)

Dipswitch 8 is used to set the corresponding resolution of the factory monitor.

Dip switch position ON supports the low resolution monitor.

Dip switch position OFF supports the high resolution monitor.

Note: If you do not know the resolution, test both settings.

Note: Dip4 and 7 are out of function and have to be set to **OFF**.

After each Dip-switch-change a power-reset of the interface box has to be performed!

1.7. Settings of the 4 Dip switches (CAN function - red)

Dip position down is **ON** and position up is **OFF**.

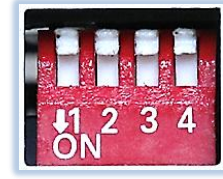

Navigation / Sy5tem	Dip 1	Dip 2	Dip 3	Dip 4
NAC infotainments	OFF	OFF	OFF	OFF

Set all 4 dips to OFF.

After each Dip-switch-change a power-reset of the Can-box has to be performed!

2. Installation

To install the interface, first switch off the ignition and disconnect the vehicle's battery. Please read the owner's manual of the car, regarding the battery's disconnection! If required, enable the car's Sleep-mode (hibernation mode) In case the sleep-mode does not succeed, the disconnection of the battery can be done with a resistor lead.

As with any installation of retrofit equipment, a stand-by test is necessary after the installation of the video interface, to ensure that the unit also switches off after reaching the vehicle's sleep mode.

Before the final installation, we recommend a test-run of the interface. Due to changes in the production of the vehicle manufacturer, there's always the possibility of incompatibility.

2.1. Place of installation – video-interface

The video-interface is performed to be installed at the head unit's rear side.

Erfahrungswerte zu Einbauorten:

Radio/Navi in **Peugeot 2008 FY 2019** vehicles: Directly behind the display.

Head Units in **Peugeot 5008** and Opel **Grandland X** vehicles: Behind the centre console (for this, remove the panel in the passenger footwell).

Attention!
Do not connect to vehicle monitor
damage to hardware!

2.2. Connection schema

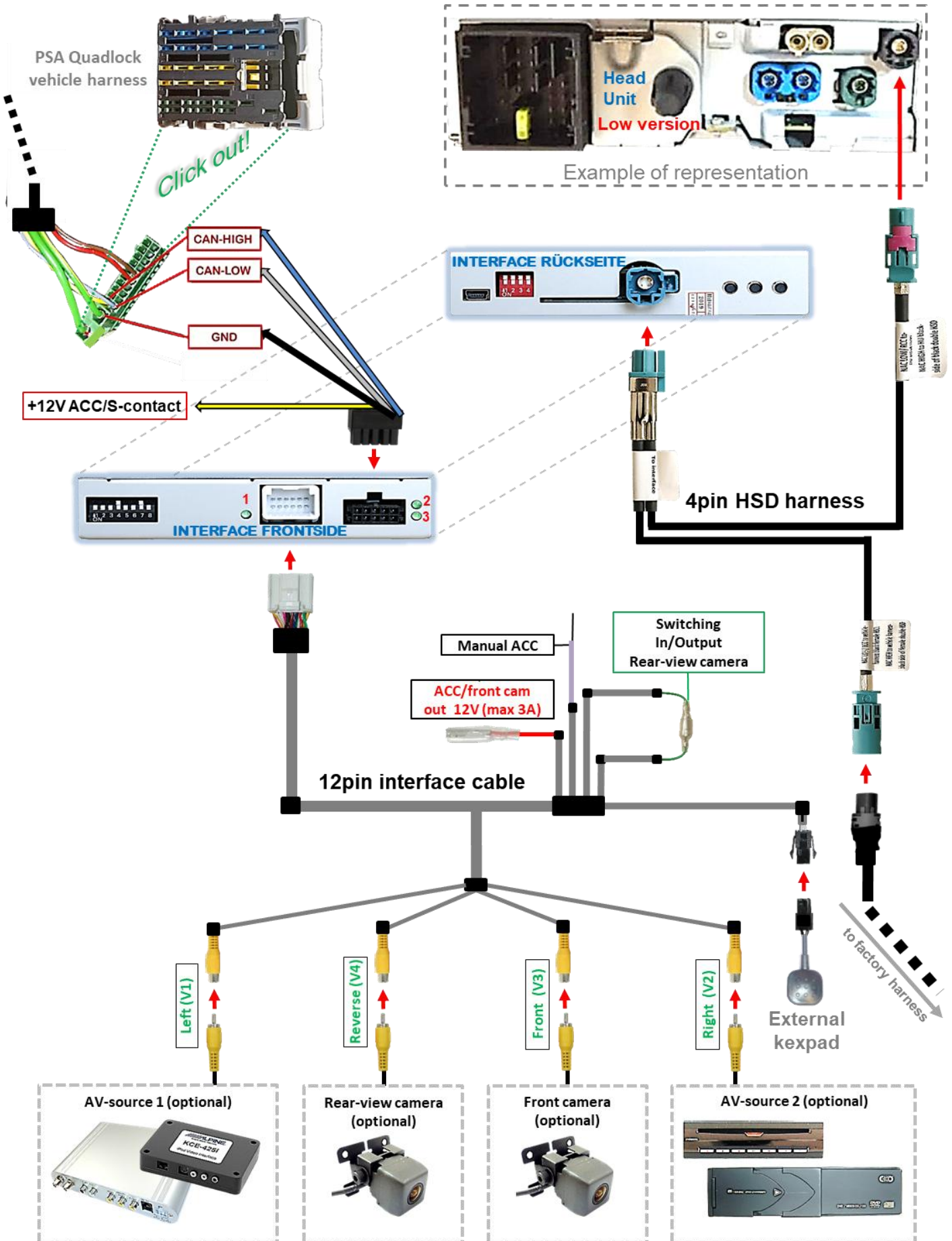

2.3.1.2. High version head unit (4 X 4pin HSD)



Attention!
Do not connect to vehicle monitor
damage to hardware!

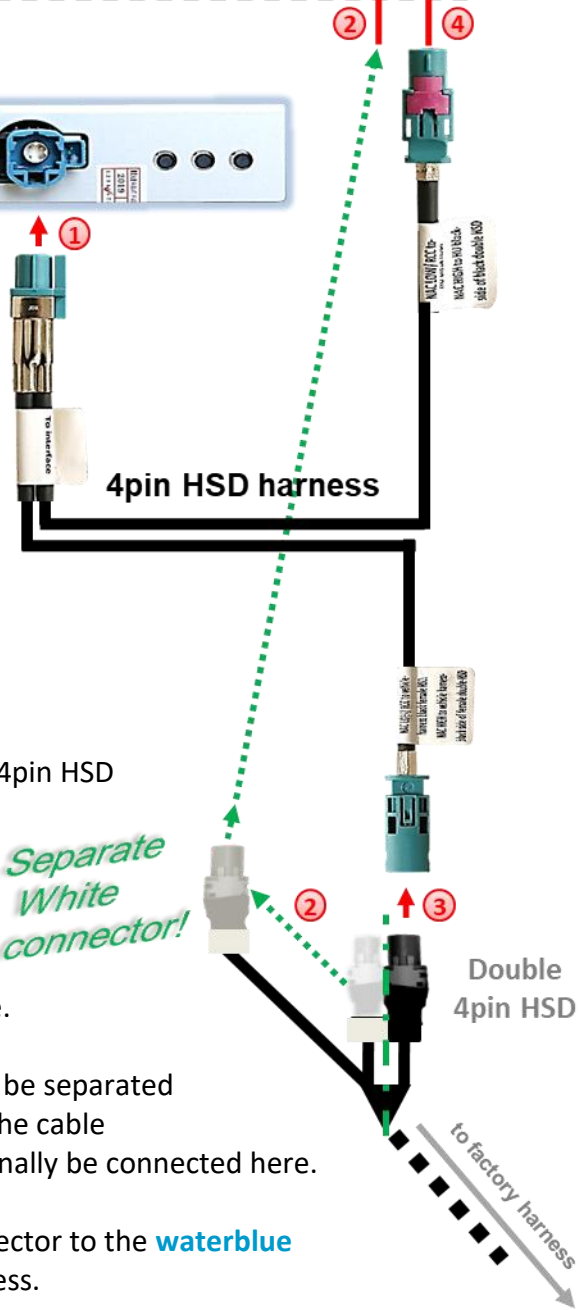

- 1 Connect the single **waterblue** female 4pin HSD connector of the 4pin HSD harness to the **waterblue** 4pin HSD connector of the video interface.
- 2 Disconnect the vehicle harness' female double 4pin HSD connector at the head unit's rearside, separate the white 4pin HSD connector from the black one and again connect the single white 4pin HSD connector to the head-unit's same male 4pin HSD connector, where it has been connected before.

Separate White HSD connector!

Special case: If the two HSD connectors cannot be separated for the reconnection of the white HSD socket, the cable **CAB-HSD-MF100** or **CAB-HSD-MF026** can optionally be connected here.

- 3 Connect the female black single 4pin HSD connector to the **waterblue** male 4pin HSD connector of the 4pin HSD harness.

Connect the opposite **waterblue** female 4pin HSD connector of the 4pin HSD harness to the previously become free male 4pin HSD connector of the head-unit.



Attention: The picture's representation of the double 4-pin HSD connector may be reversed. Make sure that the white 4pin HSD connector is reconnected to the same position of the head unit, where it has been connected before!

2.3.2. Connection – Power / CAN

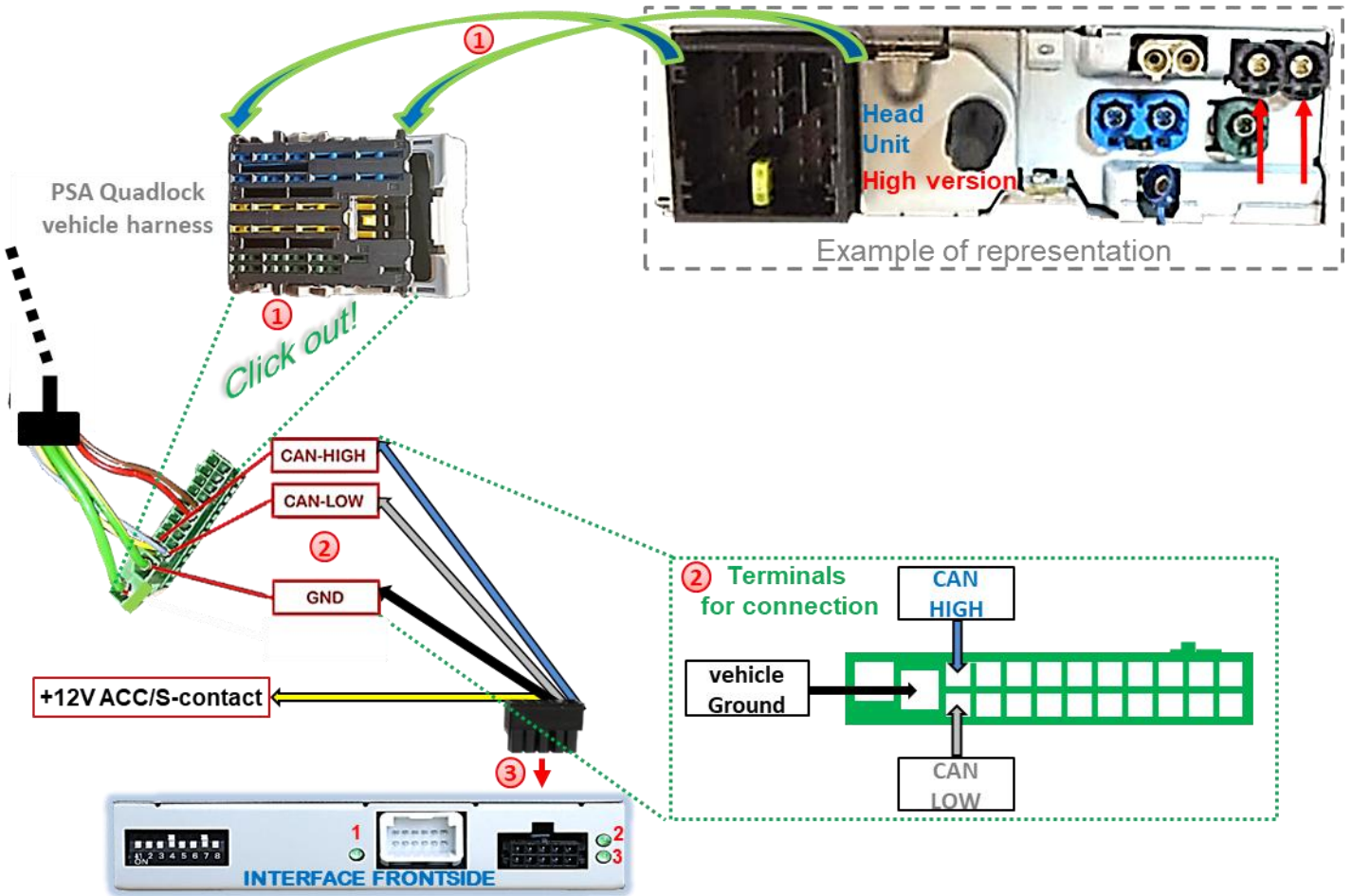

- ① Disconnect the female PSA Quadlock connector at the rearside of the head unit and click out the green female 22pin connector of the female PSA Quadlock connector.
- ② Connect the single four cables of the power/CAN cable to **+12V ACC/S-contact (terminal 15r/86s)** and exactly to the 22pin connector's shown chambers, as the vehicle's cable colours may vary!
- ③ Connect the power/CAN cable's female 10pin connector to the 10pin connector of the video interface.
- ④ Reconnect the green female 22-pin connector into the female PSA Quadlock connector and plug the female PSA Quadlock connector back into the rear side of the head unit.

Check 1
 Exceptionally, the CAN communication may not succeed in all vehicles! If, after connecting the PNP harness, no interface LED lightens up while the ignition is turned on, the analog power supply needs additionally to be done! (see chapter "Analogue power supply")



Check 2
 Exceptionally, the power supply to the video interfaces may not be interrupted after switching to the vehicle's sleep mode. If the interface LEDs continue to shine even in the vehicle's sleep mode, please contact the support!

2.3.3. Installation with analogue connection (without CAN-Bus)

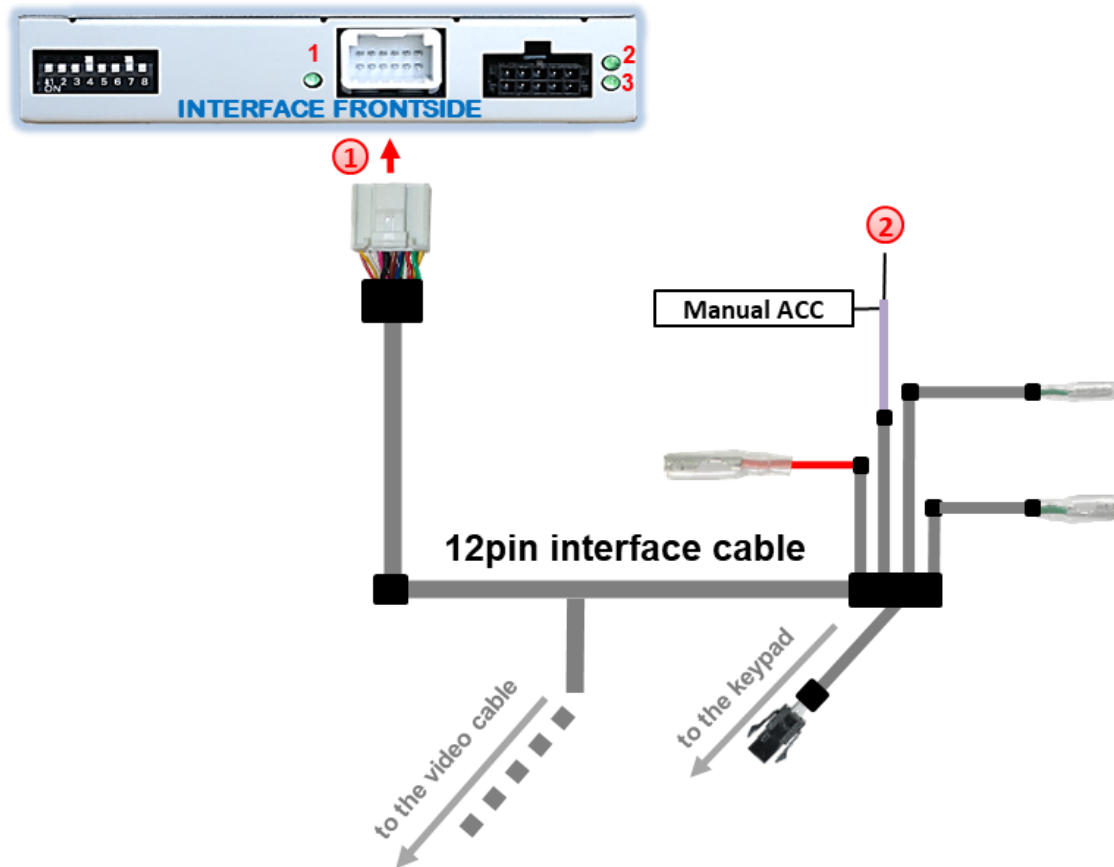

- 1 Connect the female 12pin connector of the 12pin interface cable to the male 12pin connector of the video interface.
- 2 Connect the 12pin interface cable's purple wire **Manual ACC** to **+12V ACC/S-contact (terminal 15r/86s)** (e.g., glove compartment illumination).

2.4. Power supply output

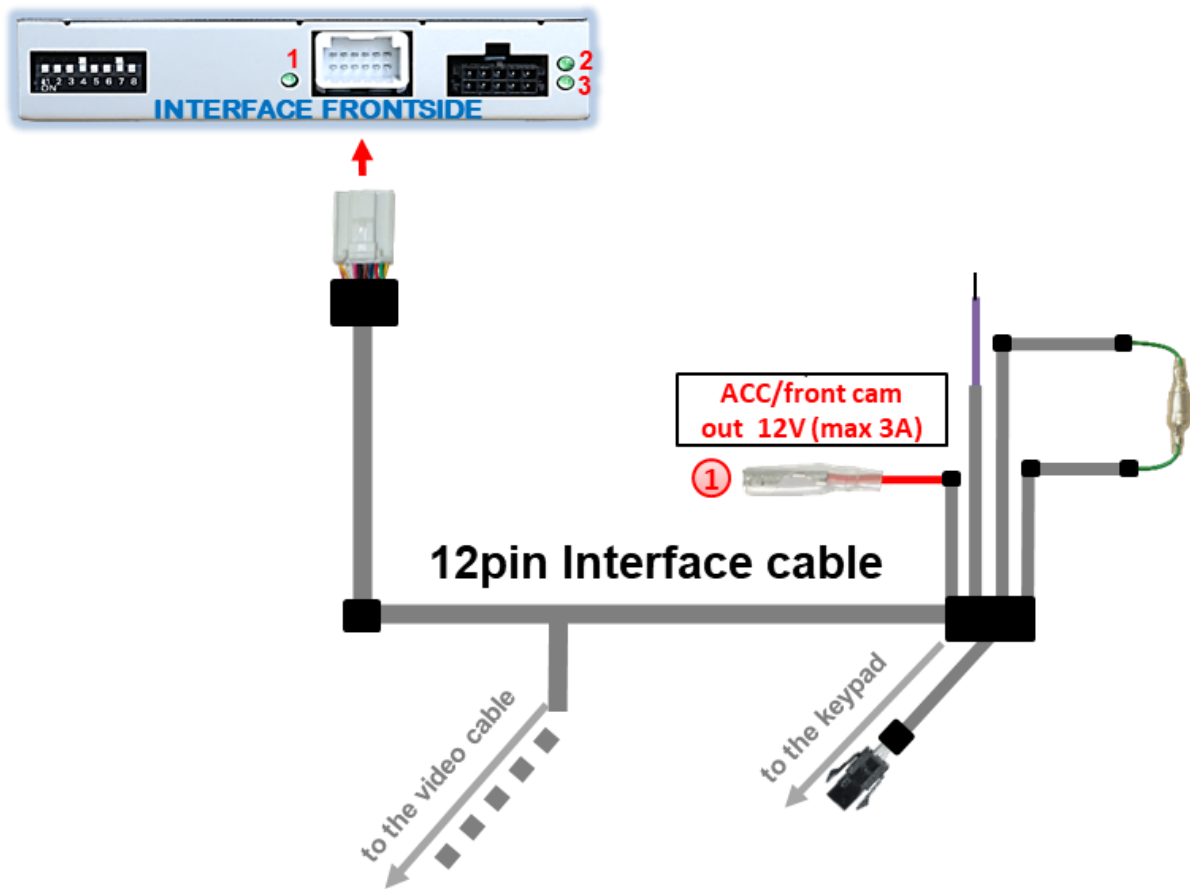

The red power supply output **ACC/front cam out 12V (max 3A)** can be used to power an external source and has a different assignment depending on the position of dip switch 1 (of the black 8 dips):

Dip	Function
Dip 1 ON	+12V (max. 3A) when reverse gear is engaged incl. 10 seconds delay after reverse gear is disengaged and +12V by manual switching to front camera by keypad (short press)
Dip 1 OFF	+12V (max. 3A) simulated ACC (while CAN has activity)

2.5. Connection - video sources

It is possible to connect two after-market video-sources, an after-market rear-view camera and an after-market front camera to the video-interface.

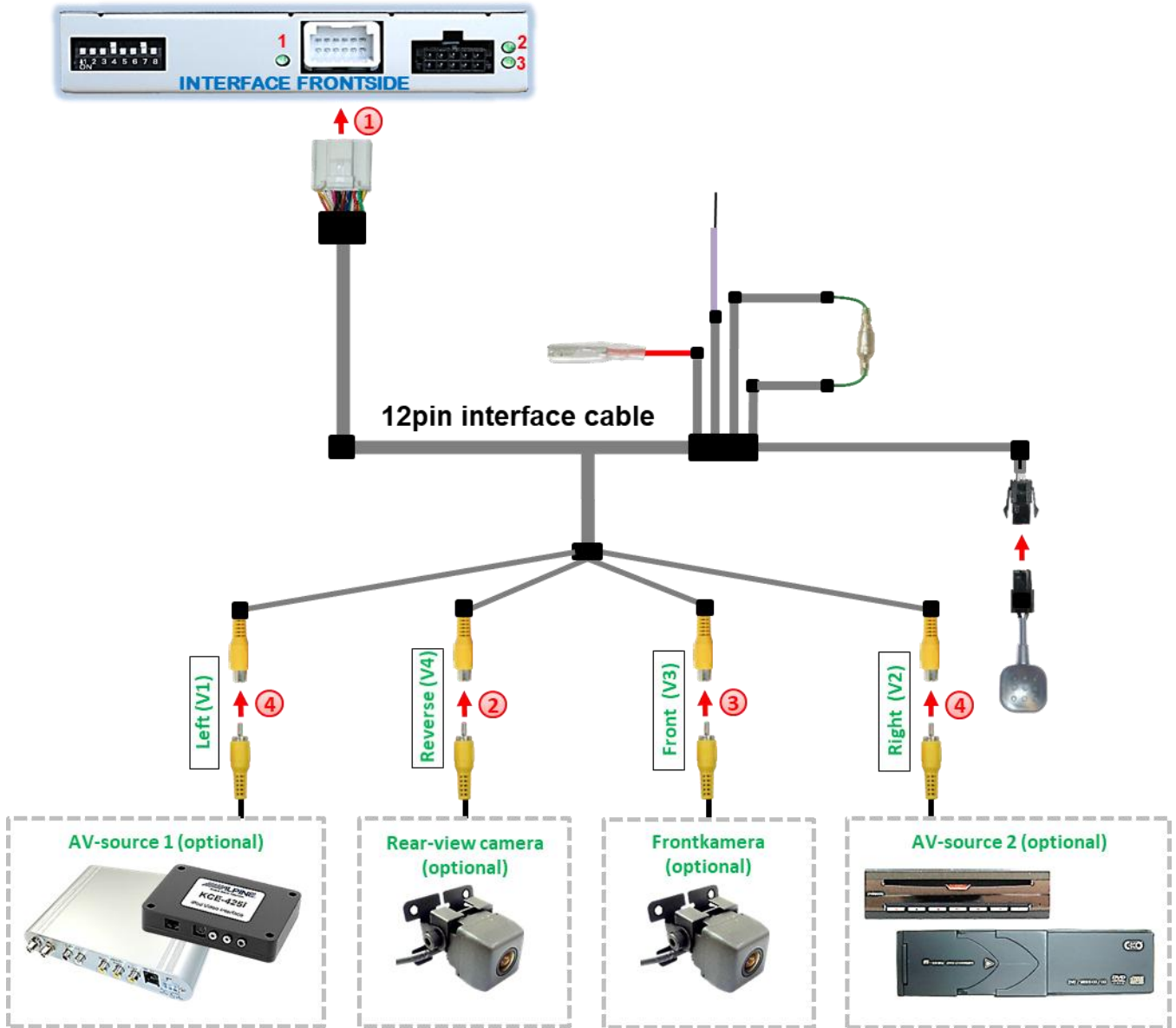

- ① Connect the 12pin interface cable's female 12pin connector to the male 12pin connector of the video-interface.
- ② Connect the video RCA of the rear-view camera to the 12pin interface cable's female RCA connector „Reverse V4“.
- ③ Connect the front camera's video RCA connector to the 12pin interface cable's female RCA connector „Front V3“.
- ④ Connect the video RCA of the AV source 1 and 2 to the 12pin interface cable's female RCA connector “Left (V1)” and “Right (V2)”.

2.5.1. Audio insertion

This interface can only insert video signals into the factory infotainment. If an AV source is connected, the audio insertion has to be performed by a factory aux input or an FM modulator. The inserted video-signal can be activated simultaneously to each audio-mode of the factory infotainment.

If 2 AV-sources shall be connected to the infotainment, for audio switching an additional electronic part is required.

2.5.2. After-market front camera

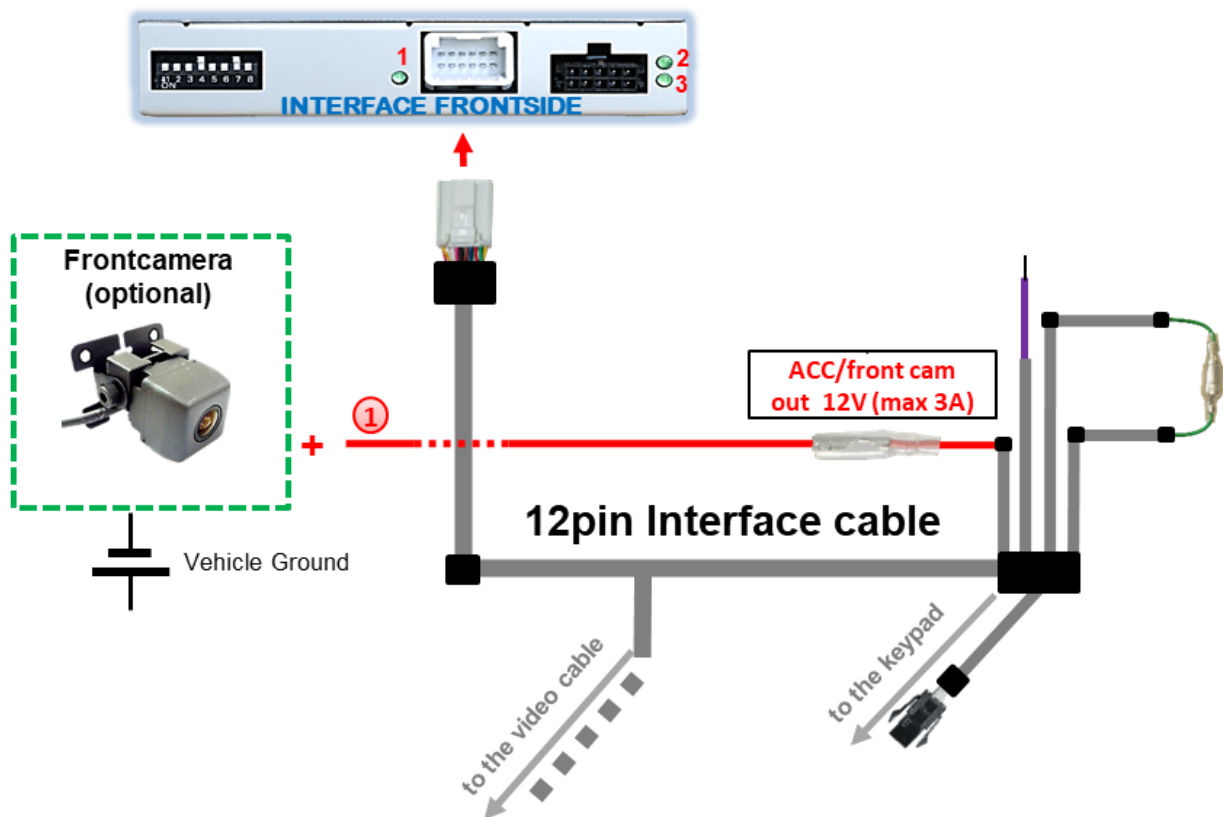

- 1 The red power supply output **ACC/front cam out 12V (max 3A)** can be used to power a front camera. If Dip 1 is set to ON (of the black 8 dips), the power supply output supplies +12V (max 3A) when the reverse gear is engaged and additionally 10 seconds delay after reverse gear is disengaged.

Note: In addition, a manual switch-over to the front camera input is possible via keypad (short press) from any image mode. The power supply output supplies +12V then, too (if Dip 1 is set to ON and the front camera input is selected).

2.5.3. After-market rear-view camera

Some vehicles have a different reverse gear code on the CAN-bus which the video-interface is not compatible with. Therefore, there are two different ways of installation. If the video interface receives a signal of the reverse gear, the green wire “Reverse-OUT” of the 20pin cable should carry +12V while the reverse gear is engaged.

Note: Do not forget to set dip5 of the video-interface to **ON** before testing.

2.5.3.1. Case 1: Video interface receives the reverse gear signal

If the CAN-bus interface receives +12V on the green wire of the 20pin cable when reverse gear is engaged, it will automatically be switched to the rear-view camera input “Camera IN” while reverse gear is engaged.

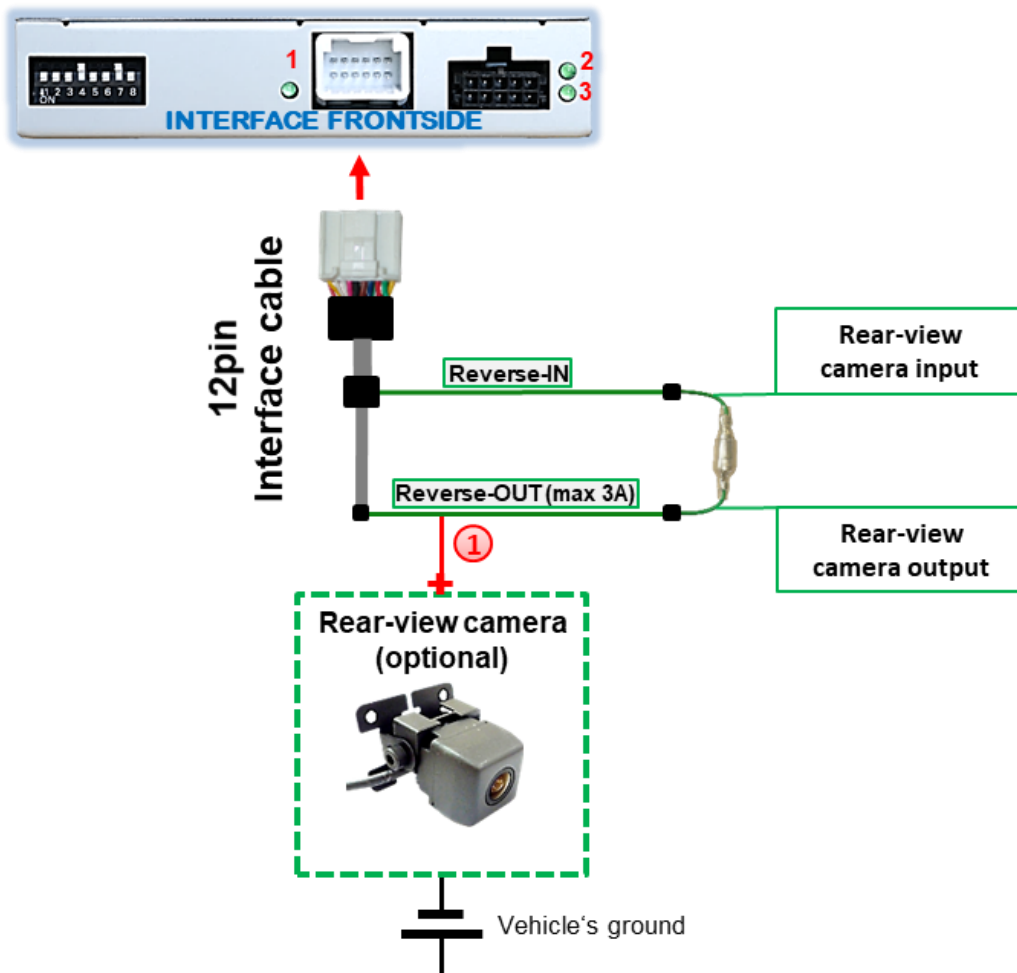

- ① The 12 V power supply for the rear-view camera (max 3A) has to be taken from the green wire of the 20pin cable to avoid an unnecessary, permanent power supply to the camera electronic.
For the operation, both green cables “Reverse IN” and “Reverse OUT” have to remain connected.

2.5.3.2. Case 2: Video interface does not receive the reverse gear signal

If the video interface does not receive +12V on the green wire of the 20pin cable when reverse gear is engaged (not all vehicles are compatible), an external switching signal from the reverse gear light is required. As the reverse gear light's power supply isn't voltage-stable all the time, an ordinary open relay (e.g., AC-RW-1230 with wiring AC-RS5) or filter (e.g., AC-PNF-RVC) is required. The diagram below shows the connection type of the relay.

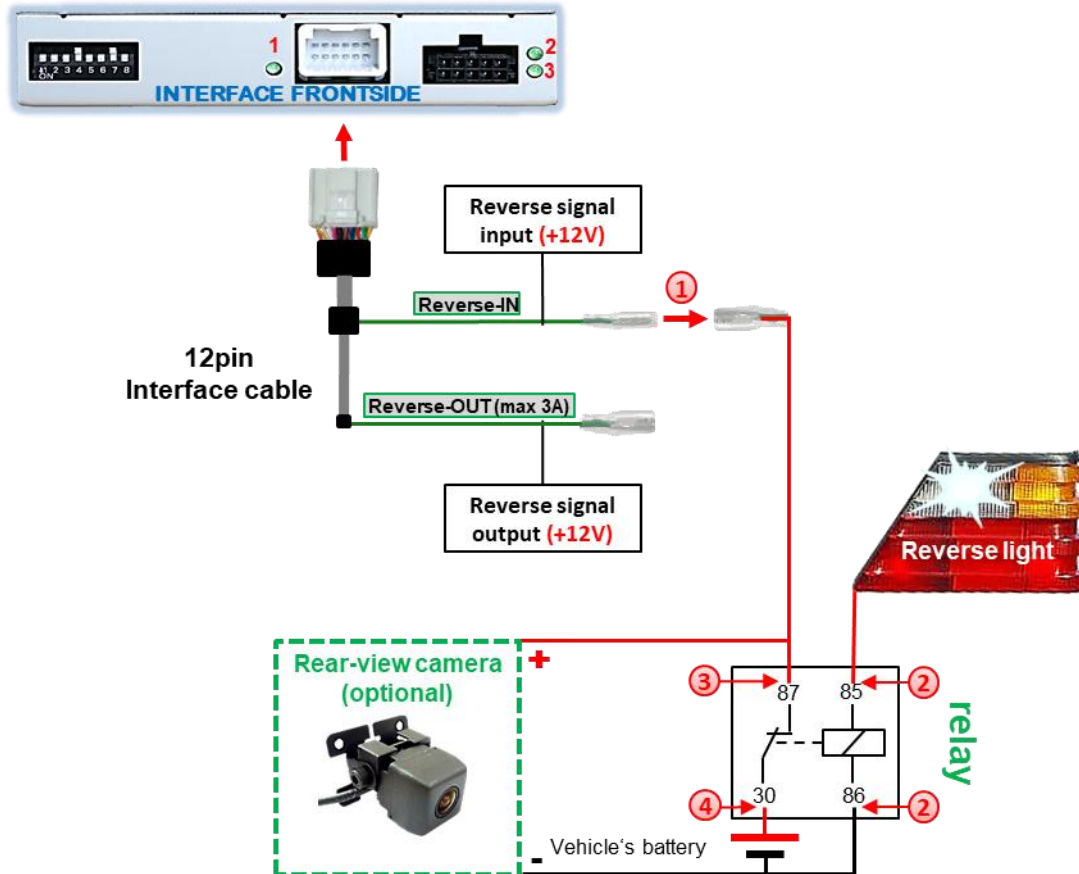

- 1 Disconnect the green cable's pre-connected male- and female connectors of the 20pin cable and connect the green input cable "Reverse-IN" to the output connector (87) of the relay.

Note: Not least to avoid short circuits, the best solution should be, to crimp a male 4mm connector to the relay's output cable and connect it to the green cable's female 4mm connector. The output-cable "Reverse-OUT" remains disconnected as it's out of function.

- 2 Connect the Reverse light's power-cable to coil (85) and the vehicle's ground to coil (86) of the relay.
- 3 Connect the output connector (87) of the relay to the rear-view camera's power-cable, like you did it to the green "Reverse-IN" cable before.
- 4 Connect permanent power / 12V to the relay's input connector (30).

2.6. Connection - external keypad

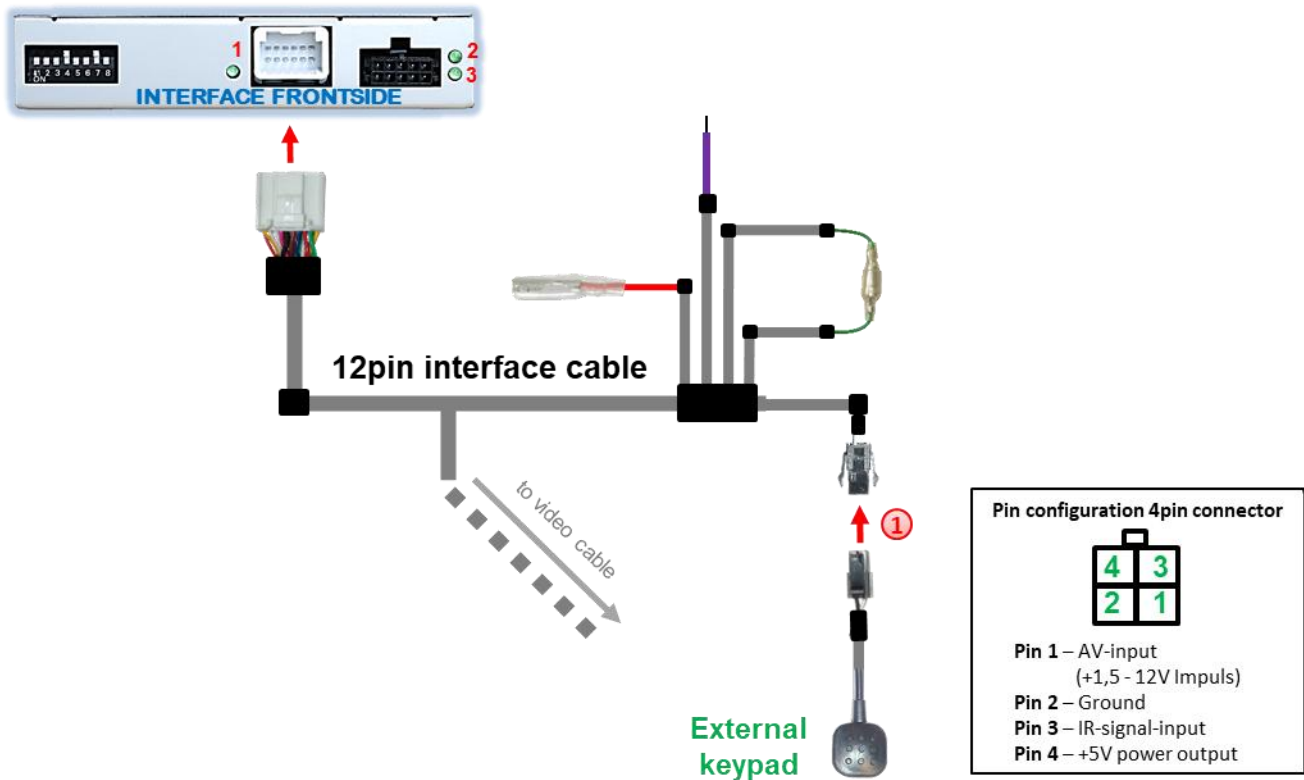

- 1 Connect the keypad's female 4pin connector to the video-interface's male 4pin connector.

Note: Even if the switching through several video sources by the keypad mightn't be required, the invisible connection and availability is strongly recommended.

2.7. Picture settings and guide lines

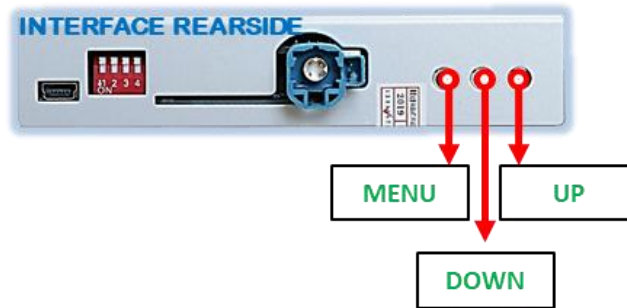

The picture settings can be adjusted by the 3 buttons on the video-interface. Press the **MENU** button to open the OSD settings menu. To switch to the next menu item, pressing **UP** and **DOWN** will change the selected value. The buttons are embedded in the housing to avoid accidental changes during or after installation. The picture settings have to be done separately for AV1 and AV2 while the corresponding input is selected and visible on the monitor.

Note: The OSD menu is only shown when a working video source is connected to the selected video-input of the interface.

The following OSD settings are available:

Contrast	
Brightness	
Saturation	
Position H	horizontal picture position
Position V	vertical picture position
Guide-Pos	Guide lines position
UI-CNTL	Options see pink box
H-SIZE (horizontal)	horizontal picture size
V-SIZE (vertical)	vertical picture size
StartDelay*	Switch delay of the interface at start-up*

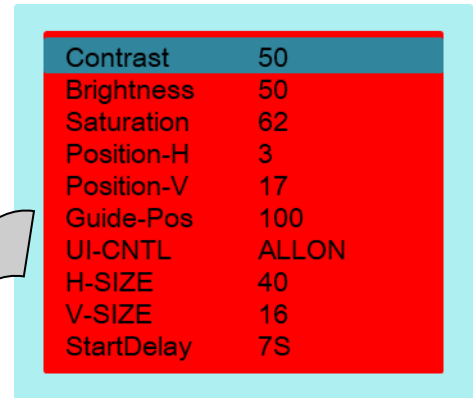

Contrast	50
Brightness	50
Saturation	62
Position-H	3
Position-V	17
Guide-Pos	100
UI-CNTL	ALLON
H-SIZE	40
V-SIZE	16
StartDelay	7S

Options UI-CNTL:

ALL ON: Guide lines and PDC will be displayed.

PDC ONLY: Only PDC displayed.

GUIDE ONLY: Only Guide lines displayed.

ALL OFF: Guide lines and PDC will not be displayed.

The menu's point „UI-CNTRL“ does support the guide lines options like shown beside:

Note: If, when adjusting the guide lines position, the lines do not move despite a change in value, the change can be seen after disengaging and re-engaging the reverse gear.

Note: If the vehicle's CAN communication does not support the video interface, the optical PDC and the guide-lines cannot be used, even if they're once shown with the first operation!

* **StartDelay** is a switch delay of the interface at start-up. This function is technically necessary in some vehicles, as otherwise the factory system may malfunction (e.g. black screen, touch problems).

The following options are available (in seconds): 0s/5s/7s/10s/15s
Changing the default settings may cause malfunctions!

3. Interface operation

3.1. By Navi button

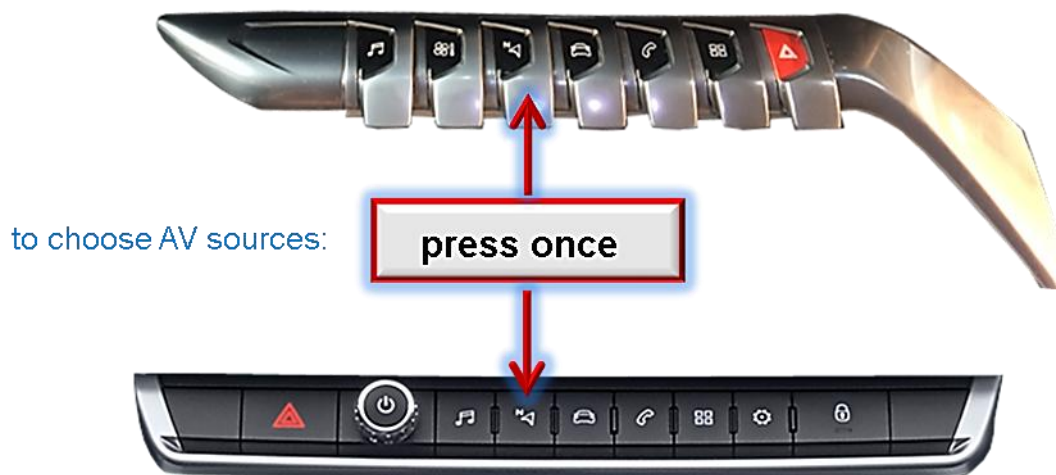

A press of the infotainment's "Navi"-button switches the input from factory mode to the inserted video sources. If, by dip switch setting, all inputs are enabled, the order is the following:

Factory video → video IN1 → video IN2 → factory video →...

By dip switch deactivated inputs will be skipped.

Switchover by vehicle buttons isn't possible in all vehicles. In some vehicles the external keypad has to be used.

3.2. By keypad

Alternatively or additionally to the infotainment's "Navi" button, the interface's enabled inputs can also be switched by the external keypad.

➤ Long press of keypad (2-3 seconds)

By long pressing the external keypad (2-3 seconds), the video interfaces switches the input from the factory video to the inserted video sources. If all inputs are activated by dip switch settings, the order is the following:

Factory video → Left (V1) → Right (V2) → factory video

Each long press will switch to the next enabled input. Inputs which are not enabled will be skipped.

Note: The interface switches after releasing the switch (after long pressure).

➤ Short press of keypad (only if DIP 1 is set to ON)

By short pressing the external keypad, the video interfaces switches from the factory video to the front camera input and back to factory video.

4. Specifications

BATT/ACC range	7V - 25V
Stand-by power drain	5mA
Power	325mA @12V
Video input	0.7V – 1V
Video input formats	NTSC
Temperature range	-40°C to +85°C
Dimensions Video-Box	118 x 23 x 105 mm (W x H x D)

5. FAQ – Trouble shooting Interface functions

For any troubles which may occur, check the following table for a solution before requesting support from your vendor.

Symptom	Reason	Possible solution
No picture/black picture (factory picture).	Not all connectors have been reconnected to factory head-unit or monitor after installation.	Connect missing connectors.
	No power on CAN-bus box (all LED CAN-bus box are off).	Check power supply of CAN-bus box. Check CAN-bus connection of CAN-bus box.
	CAN-bus box connected to CAN-bus in wrong place.	Refer to the manual where to connected to the CAN-bus. If not mentioned, try another place to connect to the CAN-bus.
	No power on video-interface (all LED video-interface are off).	Check whether CAN-bus box delivers +12V ACC on red wire output of 8pin to 6pin cable. If not cut wire and supply ACC +12V directly to video-interface.
No picture/black picture/white picture (inserted picture) but factory picture is OK.	No picture from video source.	Check on other monitor whether video source is OK.
	No video-source connected to the selected interface input.	Check settings dips 1 to 3 of video interface which inputs are activated and switch to corresponding input(s).
	LVDS cables plugged in wrong place.	Double-check whether order of LVDS cables is exactly connected according to manual. Plugging into head-unit does not work when the manual says to plug into monitor and vice versa.
	Wrong monitor settings of video-interface.	Try different combinations of dips 7 and 8 of video-interface. Unplug 6pin power after each change.
Inserted picture totally wrong size or position.	Wrong monitor settings of video-interface.	Try different combinations of dips 7 and 8 of video-interface. Unplug 6pin power after each change.
Inserted picture double or 4 times on monitor.		
Inserted picture distorted, flickering or running vertically.	Video sources output set to AUTO or MULTI which causes a conflict with the interfaces auto detection.	Set video source output fixed to PAL or NTSC. It is best to set all video sources to the same standard.
	If error occurs only after source switching: Connected sources are not set to the same TV standard.	Set all video sources to the same standard.
	Some interfaces can only handle NTSC input.	Check manual whether there is a limitation to NTSC mentioned. If yes, set source fixed to NTSC output.
Inserted picture b/w.	Picture settings have not been adjusted.	Use the 3 buttons and the interface's OSD to adjust the picture settings for the corresponding video input.
Inserted picture qual. bad.		
Inserted picture size slightly wrong.		
Inserted picture position wrong.		
Camera input picture flickers.	Camera is being tested under fluorescent light which shines directly into the camera.	Test camera under natural light outside the garage.
Camera input picture is bluish.	Protection sticker not removed from camera lens.	Remove protection sticker from lens.

Symptom	Reason	Possible solution
Camera input picture black.	Camera power taken directly from reverse gear lamp.	Use relay or electronics to "clean" reverse gear lamp power. Alternatively, if CAN-bus box is compatible with the vehicle, camera power can be taken from green wire of 6pin to 8pin cable.
Camera input picture has distortion.		
Camera input picture settings cannot be adjusted.	Camera input picture settings can only be adjusted in AV2 mode.	Set dip 3 of video-interface to ON (if not input AV2 is not already activated) and connect the camera to AV2. Switch to AV2 and adjust settings. Reconnect camera to camera input and deactivate AV2 if not used for other source.
Graphics of a car in camera input picture.	Function PDC is ON in the interface OSD.	In compatible vehicles, the graphics will display the factory PDC distance. If not working or not wanted, set interface OSD menu item UI-CNTRL to ALLOFF.
Chinese signs in camera input picture	Function RET or ALL is ON (function for Asian market) in the interface OSD.	Set interface OSD menu item UI-CNTRL to ALLOFF or PDCON.
Not possible to switch video sources by OEM button.	CAN-bus interface does not support this function for vehicle.	Use external keypad or cut white wire of 6pin to 8pin cable and apply +12V impulses for AV-switching.
Not possible to switch video sources by external keypad.	Pressed too short.	For video source switching a longer press of about 2.5 seconds is required.
	SW-version of interface does not support external keypad.	Use OEM-button or cut white wire of 6pin to 8pin cable and apply +12V impulses for AV-switching.
Interface does not switch to camera input when reverse gear is engaged.	CAN-bus interface does not support this function for the vehicles.	Cut the green wire of the 6pin to 8pin cable and apply +12V constant from reverse gear-lamp signal. Use relay to "clean" R-gear lamp power.
Interface switches video-sources by itself.	CAN-bus interface compatibility to vehicle is limited.	Cut the grey wire of 6pin to 8pin and isolate both ends. If problem still occurs, additionally cut the white wire of 6pin to 8pin cable and isolate both ends.

6. Technical Support

Please note that direct technical support is only available for products purchased directly from NavLinkz GmbH. For products bought from other sources, contact your vendor for technical support.

NavLinkz GmbH
distribution/tech dealer-support
 Heidberghof 2
 D-47495 Rheinberg

Tel +49 2843 17595 00
 Email mail@navlinkz.de



Made in China