

## Video inserter RL4-NBT2

Compatible with

**BMW** vehicles F-and G-series  
with CHAMP2, NBT or NBT2 and 6.5, 7, 8.8 or 10.25inch monitor and HSD+2  
video connector

**Mini** vehicles  
with CHAMP2, NBT or NBT2 and 6.5 or 8.8inch monitor and HSD+2 video  
connector



example

**Video-inserter with rear-view camera input,  
front camera input and two additional video inputs**

### Product features

- Video-inserter for factory-infotainment systems
- CVBS video-input for one rear-view camera
- CVBS video-input for one front camera
- 2 CVBS video-inputs for after-market Video sources (e.g. DVD-Player, DVB-T Tuner)
- Automatic switching to rear-view camera input on engagement of the reverse gear
- Automatic front camera switching after disengaging reverse gear for 10 seconds
- Activatable parking guide-lines for rear-view camera (not available for all vehicles)
- Video-in-motion (ONLY for connected video-sources)
- Video-inputs NTSC compatible

## Contents

### 1. Prior to installation

- 1.1. Delivery contents
- 1.2. Checking the compatibility of vehicle and accessories
- 1.3. Boxes and connectors – video interface
- 1.4. Settings - 8 Dip switches (black)
  - 1.4.1. Activating the front camera input (dip 1)
  - 1.4.2. Enabling the interface's video inputs (dip 2-3)
  - 1.4.3. Activating the PDC function (dip 4)
  - 1.4.4. Rear-view camera setting (dip 5)
  - 1.4.5. Activating the guide-lines (dip 6)
  - 1.4.6. Monitor selection (Dip 7 and 8)
- 1.5. Settings - 4 Dip switches (CAN function – red)

### 2. Installation

- 2.1. Place of installation
- 2.2. Connection schema
- 2.3. Connection to factory head unit and monitor
  - 2.3.1. Connection - picture signal cable
  - 2.3.2. Special case BMW i3: Connection - picture signal cable
  - 2.3.3. Connection - Quadlock/CAN
  - 2.3.4. Analog power supply
- 2.4. Power supply output
- 2.5. Connection - video-sources
  - 2.5.1. Audio insertion
  - 2.5.2. After-market rear-view camera
    - 2.5.2.1. Case 1: Interface receives the reverse gear signal
    - 2.5.2.2. Case 2: Interface does not receive the reverse gear signal
- 2.6. Connection - video-interface and external keypad
- 2.7. Picture settings and guide-lines

### 3. Interface operation

- 3.1. By keypad
- 3.2. By factory infotainment buttons

### 4. Specifications

### 5. FAQ – Trouble Shooting-Interface functions

### 6. Technical support

## Legal Information

By law, watching moving pictures while driving is prohibited, the driver must not be distracted. We do not accept any liability for material damage or personal injury resulting, directly or indirectly, from installation or operation of this product. Apart from using this product in an unmoved vehicle, it should only be used to display fixed menus or rear-view-camera video when the vehicle is moving (for example the MP3 menu for DVD upgrades).

Changes/updates of the vehicle's software can cause malfunctions of the interface. Up to one year after purchase we offer free software-updates for our interfaces. To receive a free update, the interface has to be sent in at own cost. Wages for de-and reinstallation and other expenditures involved with the software-updates will not be refunded.

## 1. Prior to installation

Read the manual prior to installation. Technical knowledge is necessary for installation. The video interface's place of installation must be free of moisture and away from heat sources.

**Before the final installation in the vehicle of the video sources, we recommend a test-run to ensure the compatibility of vehicle and interface. Due to changes in the production of the vehicle manufacturer there's always a possibility of incompatibility.**

### 1.1. Delivery contents

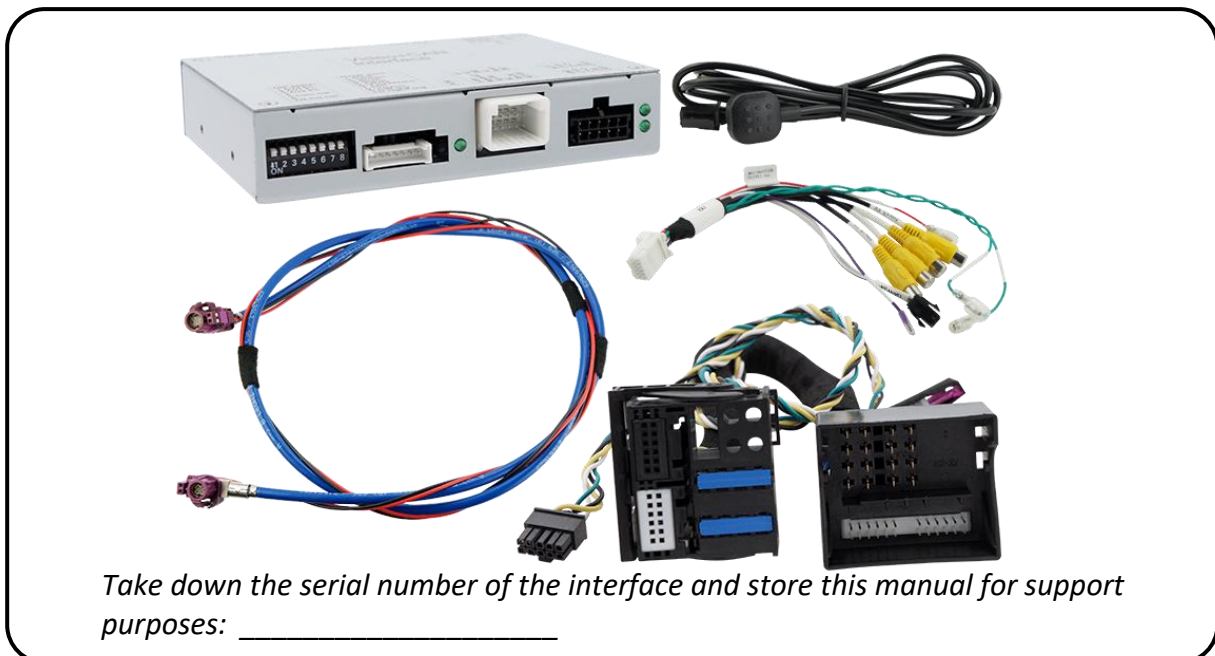

## 1.2. Checking the compatibility of vehicle and accessories

### Requirements

| Brand       | Compatible vehicles                               | Compatible systems  |
|-------------|---|---|
| <b>BMW</b>  | F-Series and G-Series vehicles from about 10/2011 | Radios<br>S6UNA Navigation<br>S606A Business Navigation<br>S609A Professional Navigatio<br>S6UPA Navigation Plus.<br><b>E.g., head-units CHAMP2, NBT or NBT2 (EVO) with 6.5inch, 7inch, 8.8inch or 10.25inch monitor - touch and non-touch.</b> |
| <b>Mini</b> | Vehicles from about 2012/2013                     | 6FPA Visual Boost<br>609 Professional Navigation<br><b>E.g., head-units NBT or NBT2 (EVO) with 6.5 or 8.8inch monitor - touch and non-touch.</b>  |

### Limitations

|                                  |  |
|----------------------------------|--|
| <i>Video only</i>                | Interface inserts ONLY video signals into infotainment. For inserting Audio signals either possibly existing factory audio-AUX-input or an FM-modulator can be used. |
| <i>Factory rear-view camera</i>  | Automatically switching-back from inserted video to factory rear-view camera is only possible while reverse gear is engaged.   |
| <i>After market front camera</i> | Front camera will automatically be switched for 10 seconds after disengaging the reverse gear. Manual switching to Front cameras is also possible.                   |
| <i>Driving path lines</i>        | Displayed dynamic guide-lines on after-market rear-view camera picture are not available in all vehicles.  |
| <i>PDC display</i>               | Optical display of PDC in combination with after-market rear-view camera does not work in all vehicles.  |
| <i>Video-input signal</i>        | NTSC video sources compatible only.  |

## 1.3. Boxes and connectors – video interface

The video-interface converts the video signals of connected after-market sources in a factory monitor compatible picture signal which is inserted in the factory monitor, by using separate trigger options. Further it reads the vehicle's digital signals out of the vehicle's CAN-bus and converts them for the video interface.

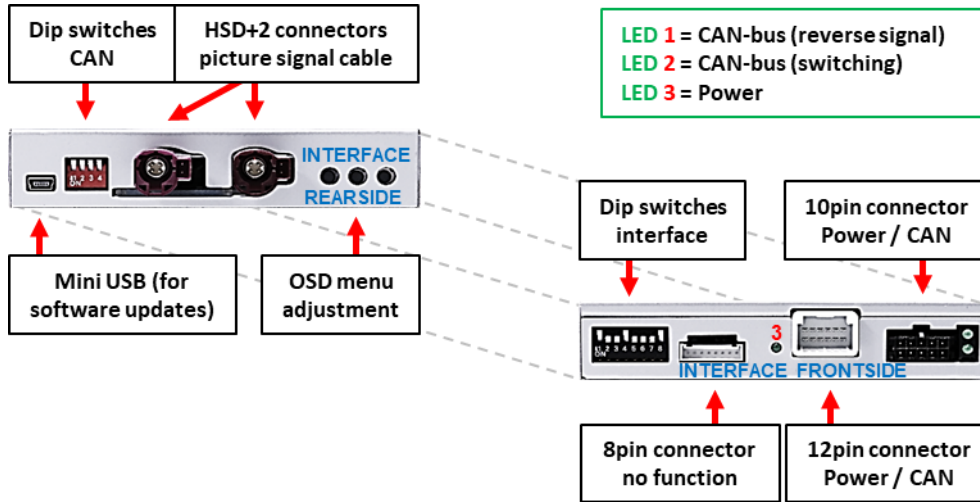

## 1.4. Settings - 8 Dip switches (black)

Some settings have to be selected by the dip-switches of the video interface.

Dip position down is ON and position up is OFF.



| Dip | Function                       | ON (down)   | OFF (up)           |
|-----|--------------------------------|---|--------------------|
| 1   | Front camera                   | enabled*  | disabled           |
|     | Power supply output (red wire) | +12V (max. 3A) when reverse gear is engaged incl. 10 seconds delay and +12V by manual switching to front camera by keypad | +12V (max. 3A) ACC |
| 2   | CVBS AV1-input                 | enabled   | disabled           |
| 3   | CVBS AV2-input                 | enabled   | disabled           |
| 4   | PDC                            | enabled   | disabled           |
| 5   | Rear-view cam type             | after-market  | factory or none    |
| 6   | Guide lines                    | enabled   | disabled           |
| 7   | Monitor adjustments            | Try all possible combinations of Dips 7 and 8 to receive the best picture (quality and size)                              |                    |
| 8   |                                |   |                    |

See the following chapters for detailed information.

**After each Dip-switch-change a power-reset of the Can-box has to be performed!**

## 1.4.1. Activating the front camera input (dip 1)

If set to ON, the interface switches for 10, 15 or 20 seconds (adjustable via the OSD menu of the RL4-NBT2) from the rear-view camera to the front camera input after having disengaged the reverse gear. In addition, a manual switch-over to the front camera input is possible via keypad (short press) from any image mode.

Description of the front camera power supply: see chapter "Power supply output".

## 1.4.2. Enabling the interface's video inputs (dip 2-3)

Only by dip switches enabled video inputs can be accessed by switching through the interface's video sources. It is recommended to enable only the required inputs. Disabled inputs will be skipped while switching through the video interfaces inputs.

## 1.4.3. Activating the PDC function (dip 4)

When set to ON, the PDC car is displayed on the monitor and the distances are displayed, based on the CAN data received.

**Note:** If the interface does not receive data from the vehicle CAN bus (some vehicles are not compatible), the parking distance cannot be displayed. In this case, set dip4 to Off.

## 1.4.4. Rear-view camera setting (dip 5)

If set to OFF, the interface switches to factory picture while the reverse gear is engaged to display factory rear-view camera or factory optical park system picture.

If set to ON, the interface switches to its rear-view camera input while the reverse gear is engaged.

## 1.4.5. Activating the guidelines (dip 6)

If set to ON, the interface is activated to show the guide lines for the rear-view camera while the vehicle is in reverse mode (not available for all vehicles).



**Note:** Some vehicles have a different code on the CAN-bus which the video-interface is not compatible with. If the interface does not completely communicate with the vehicle CAN bus, the reverse gear guide-lines can't be shown during the vehicle's operation, even if they in some vehicles once appear after having switched the system to powerless!

## 1.4.6. Monitor selection (dip 7 and 8)

Dip7 and 8 change the monitor-specific video settings.

Try all possible combinations of Dips 7 and 8 to receive the best picture (quality and size)

**After each Dip-switch-change a power-reset of the Can-box has to be performed!**

## 1.5. Settings of the 4 Dip switches (CAN functions – red)

Dip position down is ON and position up is OFF.

| Fahrzeug/Navigation          | Dip 1 | Dip 2 | Dip 3 | Dip 4 |
|------------------------------|-------|-------|-------|-------|
| BMW/Mini NBT system (Apix)   | ON    | ON    | ON    | OFF   |
| BMW/Mini NBT2 system (Apix2) | ON    | OFF   | OFF   | OFF   |
| BMW i3 NBT2 system (Apix2)   | ON    | ON    | OFF   | OFF   |



**Note:** In case of absent or defective picture representation or faulty CAN communication, also try dips 1, 2 and 3 in alternative positions! But always keep dip 4 OFF.

**After each Dip-switch-change a power-reset of the Can-box has to be performed!**

## 2. Installation

**To install the interface, first switch off the ignition and disconnect the vehicle's battery. Please read the owner's manual of the car, regarding the battery's disconnection! If required, enable the car's Sleep-mode (hibernation mode)**

**In case the sleep-mode does not succeed, the disconnection of the battery can be done with a resistor lead.**

**If the necessary stabilized power supply for the interface is not taken directly from the battery, the chosen connection has to be checked for being constantly stabile.**

**The interface needs a permanent 12V source!**

Before a final installation, we recommend a test-run to ensure the compatibility of the vehicle and the interface. Due to changes in the production of the vehicle manufacturer there's always a possibility of incompatibility.

### 2.1. Place of installation

The interface is supposed to be installed at a suitable location behind the vehicle's head-unit.

In most vehicles, the centre console must be removed for this purpose.

The connection is made to both, the head unit and the monitor.

## 2.2. Connection schema

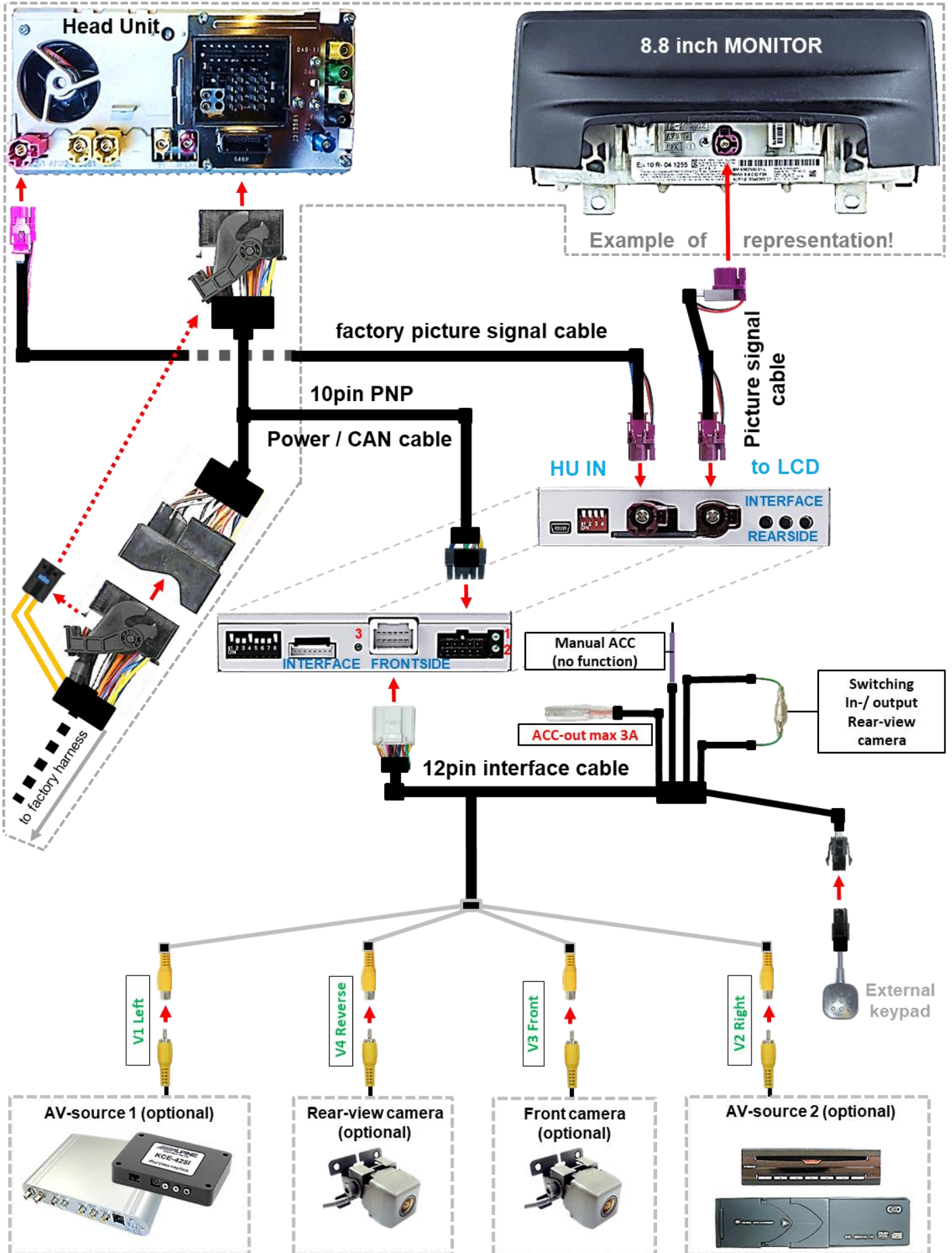

## 2.3. Connections to factory head-unit and monitor

### 2.3.1. Connection - picture signal cable

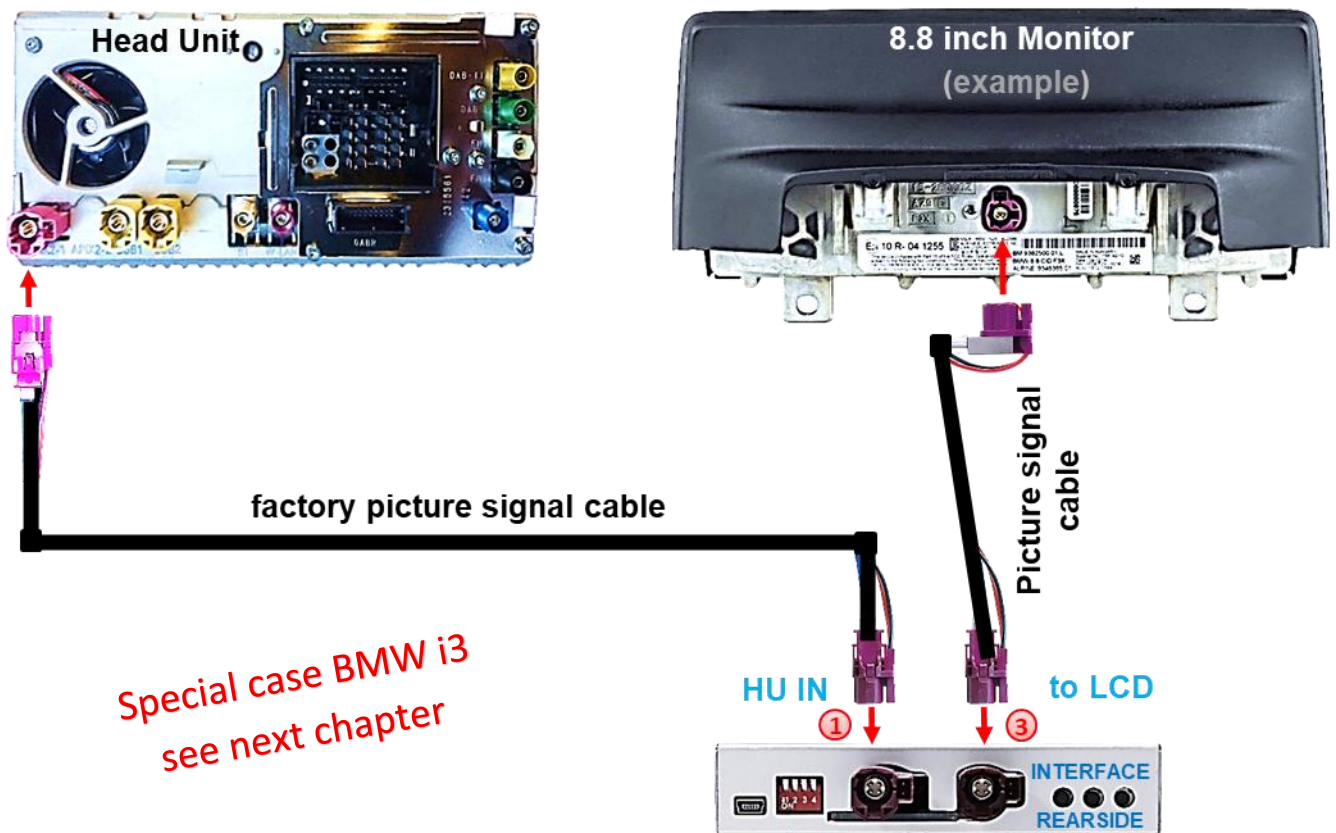

- ① Disconnect factory picture signal cable's bordeaux HSD+2 connector from rear-side of monitor and connect to bordeaux HSD+2 connector „HU IN“ of video interface .
- ② Connect angled bordeaux HSD+2 connector of enclosed picture signal cable to bordeaux HSD+2 connector at monitor's rear side.
- ③ Connect straight bordeaux HSD+2 connector of enclosed picture signal cable to bordeaux male HSD+2 connector „TO LCD“ of video interface.

**Attention:** Picture signal cable's connecting direction doesn't have an impact on system function. For that angled and straight HSD+2 connectors are allowed to be interchanged, depending on HSD+2 connectors mounting space at monitor.



**However, mixing up/interchanging the connections of „HU IN“ and „TO LCD“ will cause disfunction or even damage to the system!**

**Note:** Colours of HSD+2 connectors at monitor and head unit may vary.

## 2.3.2. Special case BMW i3: Connection - picture signal cable

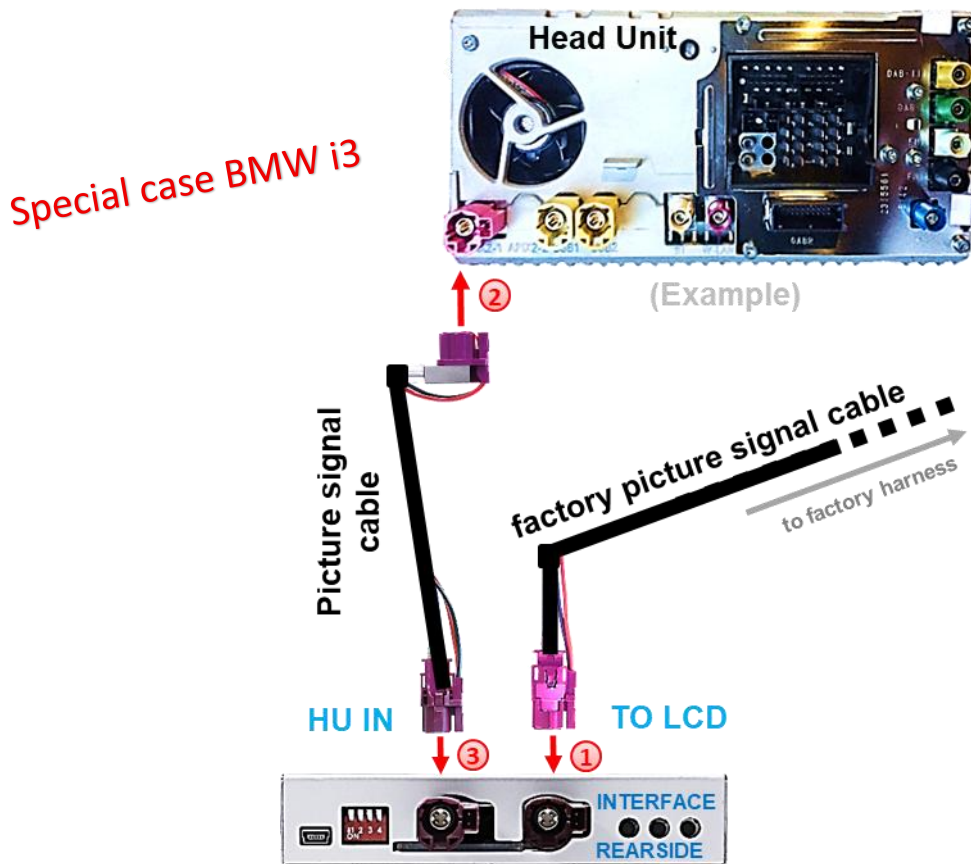

- 1 Disconnect factory picture signal cable's pink HSD+2 connector from rear-side of head unit and connect to bordeaux HSD+2 connector „TO LCD“ of video interface.
- 2 Connect angled bordeaux HSD+2 connector of enclosed picture signal cable to pink HSD+2 connector at head unit's rear side.
- 3 Connect straight bordeaux HSD+2 connector of enclosed picture signal cable to bordeaux male HSD+2 connector „HU IN“ of video interface.

**Attention:** Picture signal cable's connecting direction doesn't have an impact on system function. For that angled and straight HSD+2 connectors are allowed to be interchanged, depending on HSD+2 connectors mounting space at monitor.



**However, mixing up/interchanging the connections of „HU IN“ and „TO LCD“ will cause disfunction or even damage to the system!**

**Note:** Colours of HSD+2 connectors at monitor and head unit may vary.

## 2.3.3. Connection – Quadlock/CAN

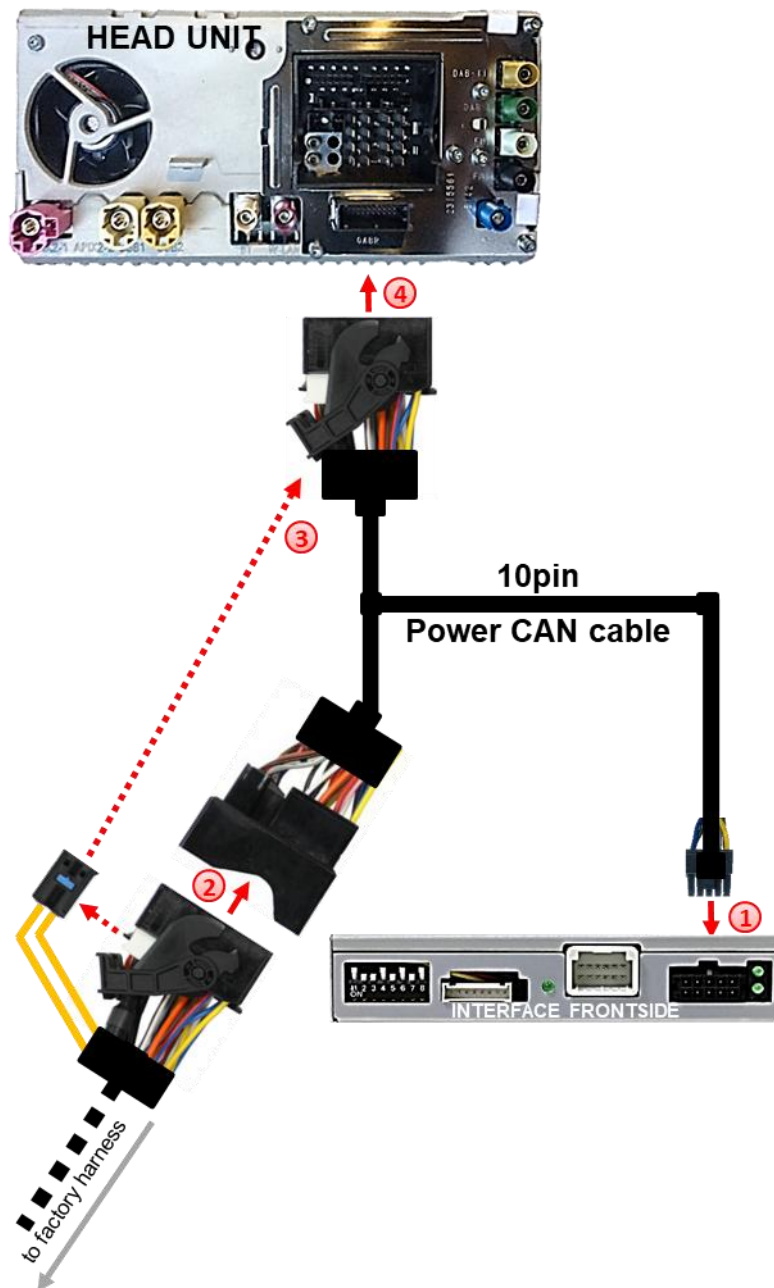

- ① Connect female 10pin connector of 10pin PNP Power / CAN cable to 10pin connector of video interface.
- ② Remove female 40pin Quadlock connector of vehicle harness from rear-side of head-unit and connect to male 40pin Quadlock connector of 10pin PNP Power / CAN cable.
- ③ Remove optical leads –if existing- from the female Quadlock connector of the vehicle harness and insert them into the female Quadlock connector of Quadlock harness at the same position.
- ④ Connect female Quadlock connector of 10pin PNP Power / CAN cable to male Quadlock connector at rear-side of head unit.

## 2.3.4. Analog power supply

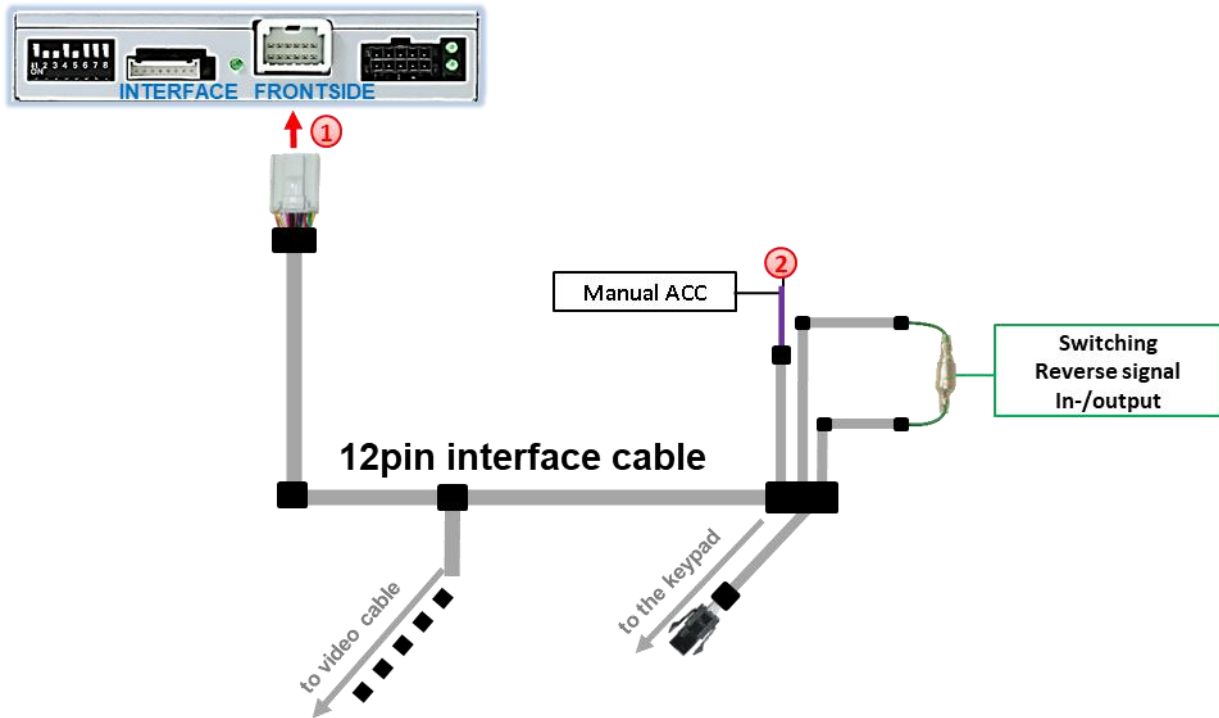

- 1 If, after connecting the PNP harness, no interface LED lightens up while the ignition is turned on, the purple-coloured wire **Manual ACC** of the 12pin interface cable has to be connected additionally to **ACC** or **S-contact terminal 86s +12V** (e.g. glove compartment illumination).

**Note:** With analogue connection of the video interface (without CAN bus), the connection of the rear-view camera must also be made manually.  
(see point **2.5.2.2.**: Case 2: Interface does not receive a reverse gear signal).

## 2.4. Power supply output

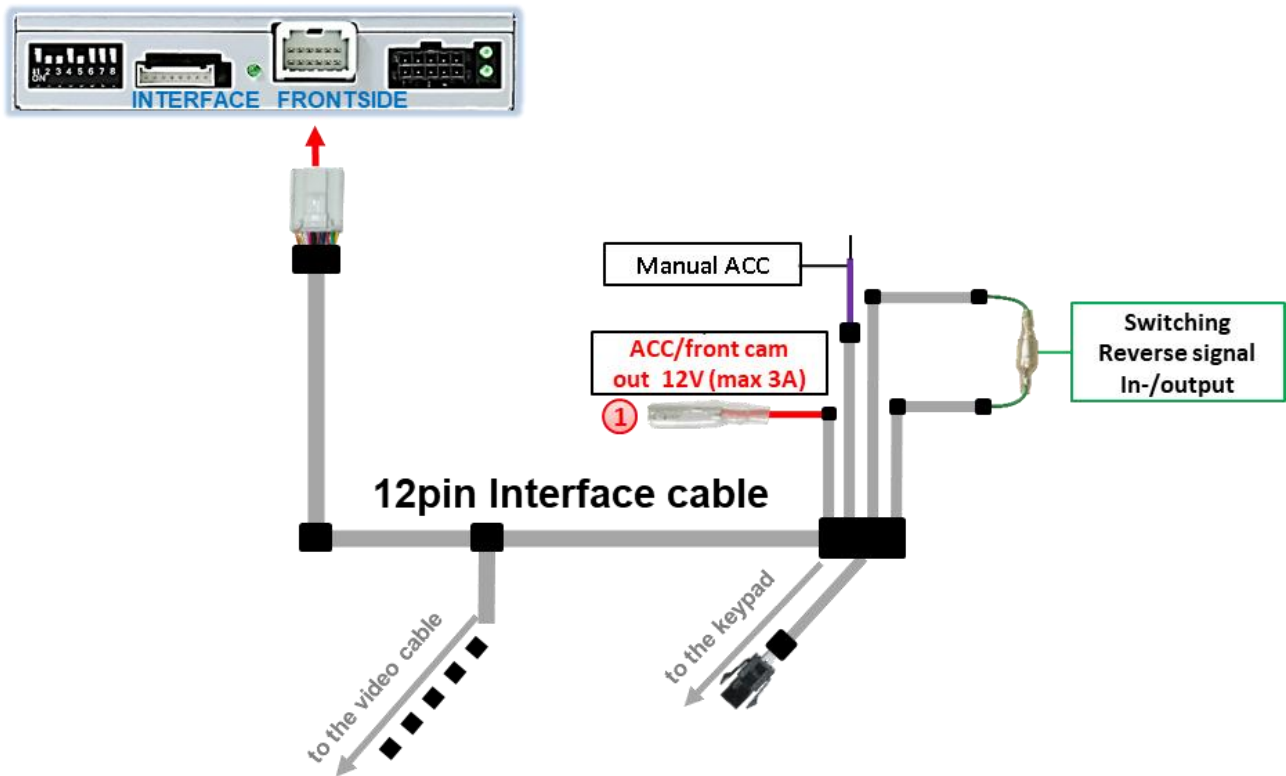

① The red power supply output **ACC/front cam out 12V (max 3A)** can be used to power an external source and has a different assignment depending on the position of dip switch 1 (of the black 8 dips):

| Dip              | Function  |
|------------------|---|
| Dip 1 <b>ON</b>  | +12V (max. 3A) when reverse gear is engaged incl. 10 seconds delay* after reverse gear is disengaged and +12V by manual switching to front camera by keypad (short press) |
| Dip 1 <b>OFF</b> | +12V (max. 3A) ACC  |

## 2.5. Connection - video sources

It is possible to connect an after-market rear-view camera, an after-market front camera and two more Video sources to the video-interface.

Before a final installation of the video sources, we recommend a test-run to ensure the compatibility of vehicle and interface. Due to changes in the production of the vehicle manufacturer there's always a possibility of incompatibility.

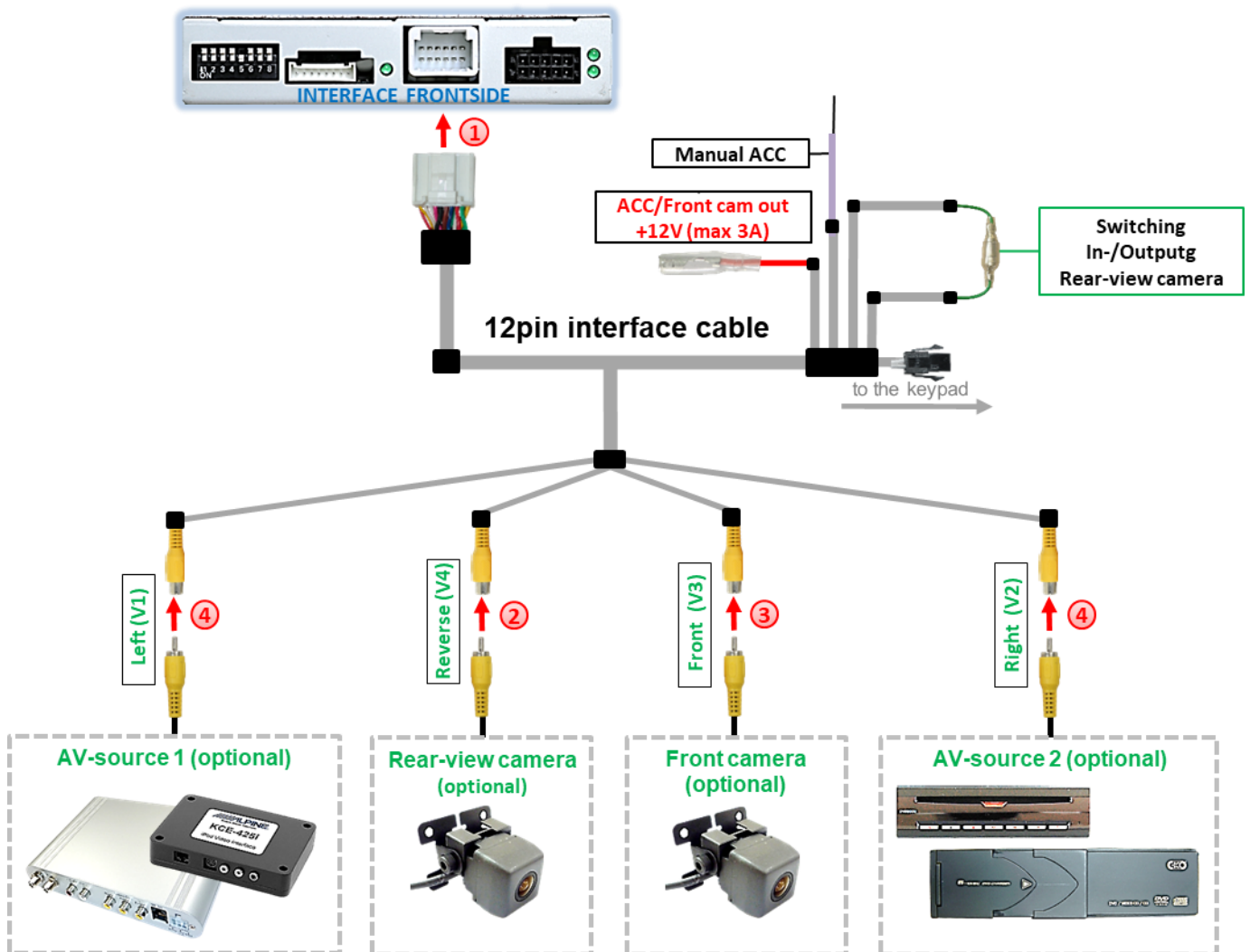

- ① Connect the 12pin interface cable's female 12pin connector to the male 12pin connector of the video-interface.
- ② Connect the video RCA of the rear-view camera to the 12pin interface cable's female RCA connector "V4 Reverse".
- ③ Connect the video RCA of the front camera to the 12pin interface cable's female RCA connector "V3 Front".
- ④ Connect the video RCA of the video source 1 and 2 to the female RCA connector "V1 Left" and "V2 Right" of the 12pin interface cable.

## 2.5.1. Audio-insertion

This interface is only able to insert video signals into the factory infotainment. If an AV-source is connected, the audio insertion has to be done by the factory audio AUX input or an FM-modulator. The inserted video-signal can be activated simultaneously to each audio-mode of the factory infotainment. If 2 AV sources shall be connected to the infotainment, additional electronic is necessary to switch the audio signals.

## 2.5.2. After-market rear-view camera

Some vehicles have a different reverse gear code on the CAN-bus which the video-interface is not compatible with. Therefore, there are two different ways of installation. If the video interface receives a signal of the reverse gear, the green wire **“Reverse-OUT”** of the 12pin cable should carry +12V while the reverse gear is engaged.

**Note:** Do not forget to set video interface’s dip5 to ON before testing.

### 2.5.2.1. Case 1: Interface receives the reverse gear signal

If the interface delivers +12V on the green output wire of the 12pin interface cable while reverse gear is engaged, the video interface will automatically switch to the rear-view camera input **“V4 Reverse”** while the reverse gear is engaged.

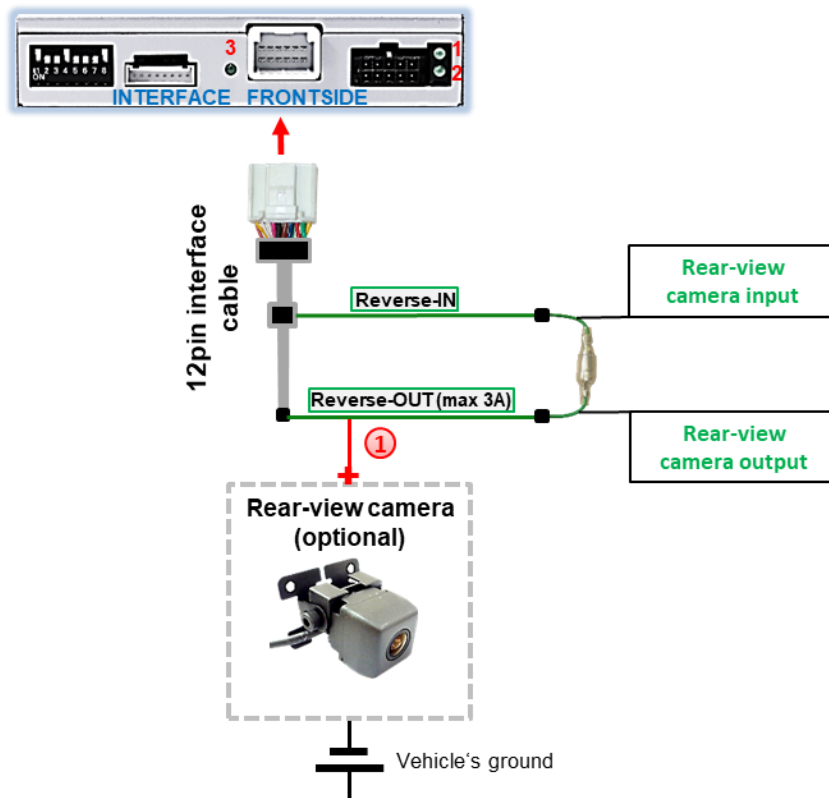

① Additionally, the +12V (max. 3A) power supply for the rear-view camera can be taken from the green wire of the 12pin interface cable.

## 2.5.2.2. Case 2: Interface does not receive the reverse gear signal

If the video interface does not deliver +12V on the green wire of the 12pin cable when reverse gear is engaged (not all vehicles are compatible), an external switching signal from the reverse gear light is required. As the reverse gear light's power supply isn't voltage-stable all the time, an ordinary open relay (e.g., AC-RW-1230 with wiring AC-RS5) or filter (e.g. AC-PNF-RVC) is required. The diagram below shows the connection type of the relay.

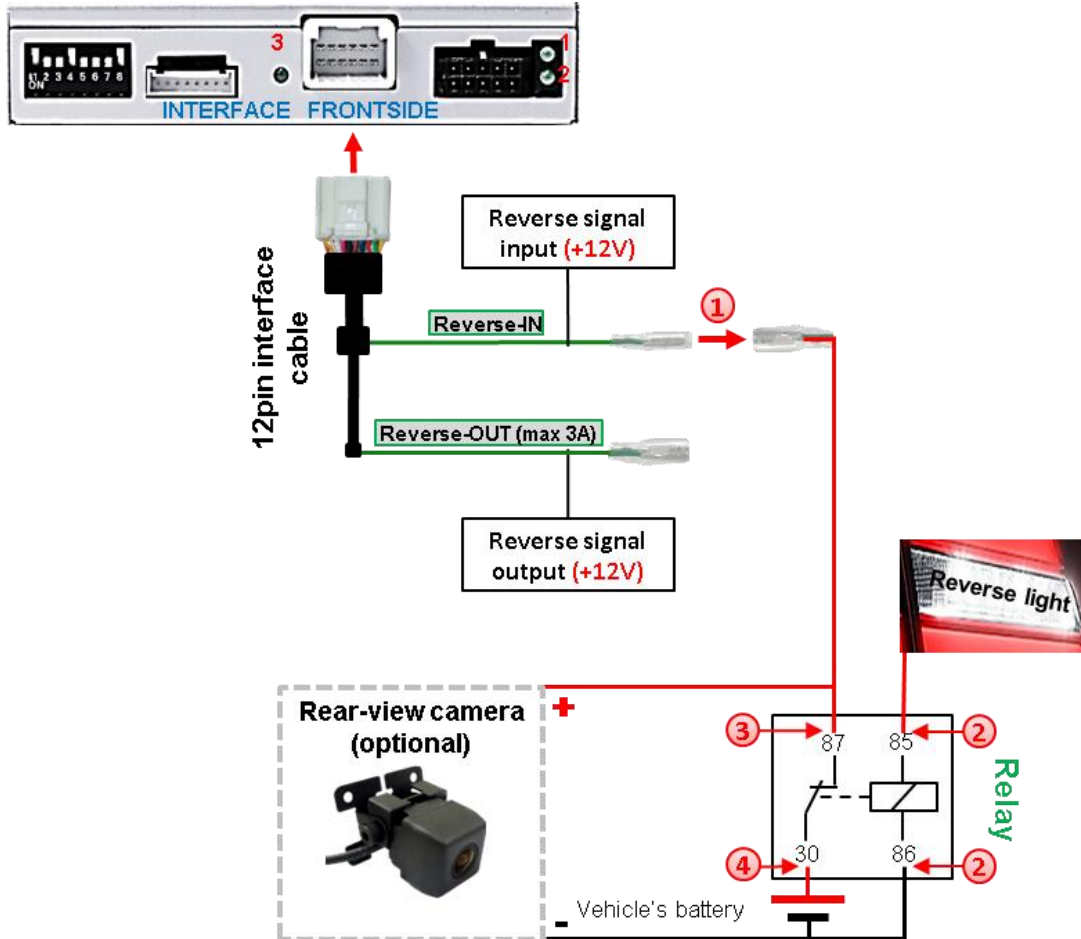

- 1 Disconnect the green cable's preconnected male- and female connectors of the 12pin interface cable and connect the green input cable "Reverse-IN" to the output connector (87) of the relay.

**Note:** Last but not lot least to avoid short circuits, the best solution should be, to crimp a male 4mm connector to the relay's output cable and connect it to the green cable's female 4mm connector. The output-cable "Reverse-OUT" remains disconnected as it's out of function.

- 2 Connect the Reverse light's power-cable to coil (85) and the vehicle's ground to coil (86) of the relay.
- 3 Connect the output connector (87) of the relay to the rear-view camera's power-cable, like you did it to the green "Reverse-IN" cable before.
- 4 Connect stabile and permanent +12V to the relay's input connector (30).

## 2.5.3. After-market front camera

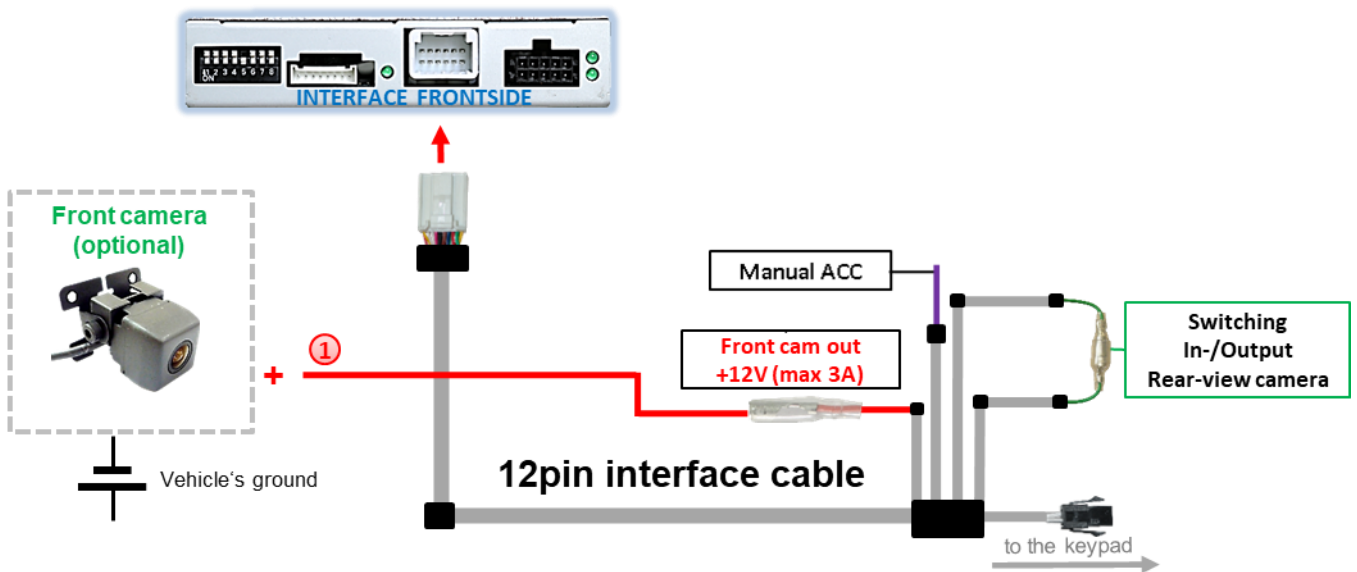

- ① The red power supply output **ACC/front cam out 12V (max 3A)** can be used to power a front camera. If Dip 1 is set to ON (black 8 dips), the power supply output gives +12V (max 3A) when reverse gear is engaged ...

**Note:** In addition, a manual switch-over to the front camera input is possible via keypad (short press) from any image mode. The power supply output gives +12V then, as well (if Dip 1 is set to ON and the front camera input is selected).

Attention: A long press of the external keypad push button will switch the interface to the next source.

## 2.6. Connection - video-interface and keypad

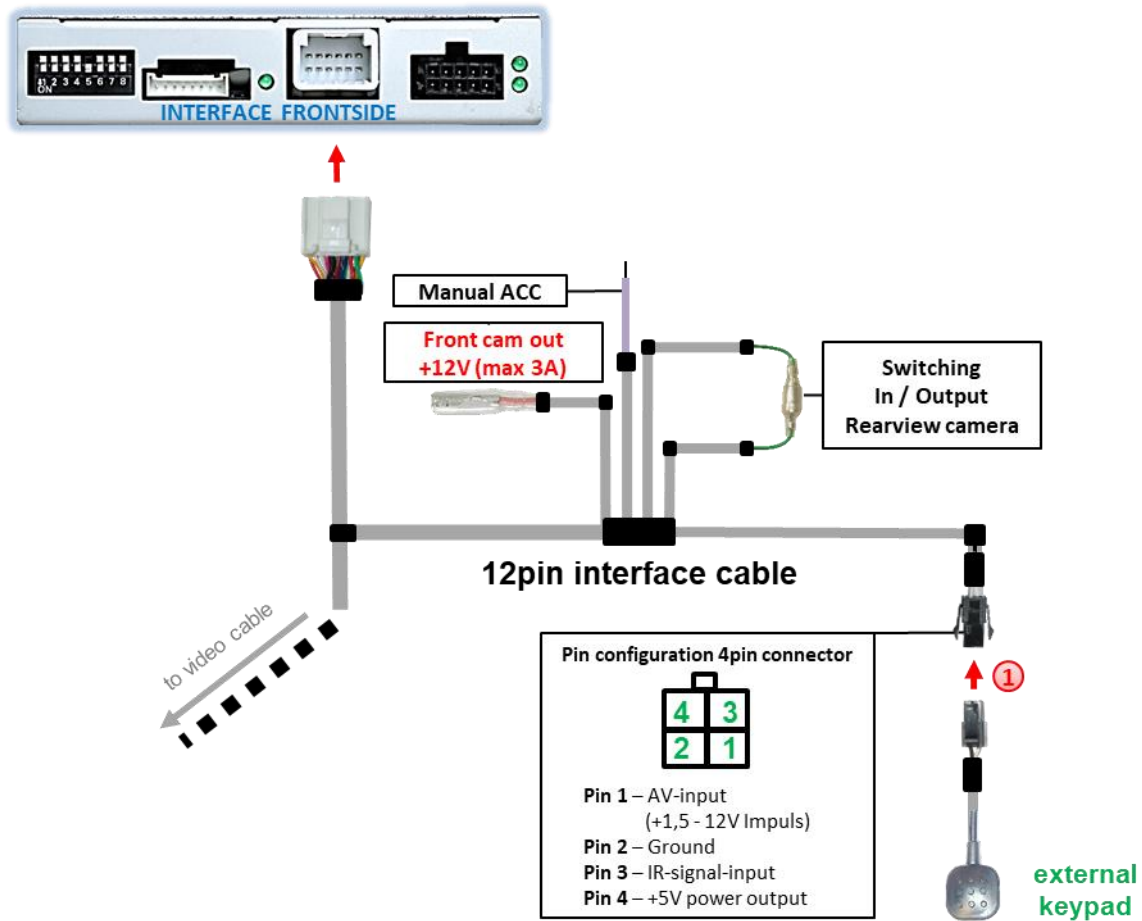

- 1 Connect the female 4pin connector of the keypad to the male 4pin connector of the 12pin interface cable.

**Note:** Even if switching through several video sources by the keypad mightn't be required, the invisible connection and availability is strongly recommended.

## 2.7. Picture settings and guide-lines

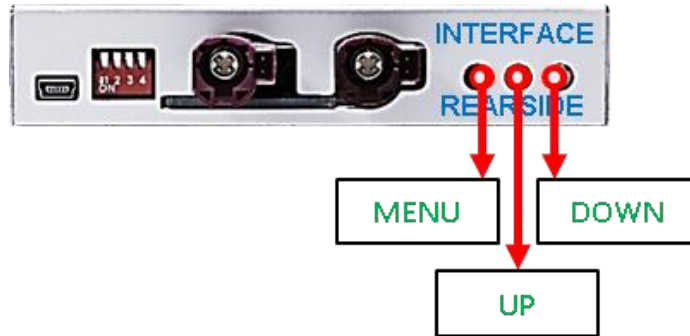

The picture settings are adjustable by the 3 push-buttons at the rear-side of the video-interface. Press the MENU button to open the OSD settings menu or to switch to the next menu item. Press UP and DOWN to change the selected value. The buttons are placed inside in the housing to avoid accidental changes during or after the installation. Picture settings must be done separately for V1, V2, V3 and V4 while the corresponding input is selected and visible on the monitor.

**Note:** The OSD menu is only shown when a working video source is connected to the selected video-input of the interface.

The following settings are available:

- Contrast
- Brightness
- Saturation
- Position H (horizontal picture position) \*
- Position V (vertical picture position) \*
- Guide-P (position-guide lines)
- H-SIZE (horizontal picture size)
- V-SIZE (vertical picture size)
- Front-CNTRL ("Delay" function front camera 10,15 or 20 seconds)

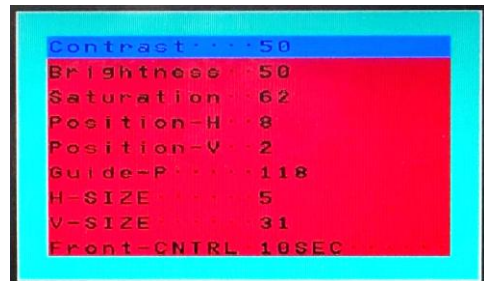

\*In case of unchangeable values, the system supports an automatic picture adjustment.

**Note:**

To adjust the reverse picture, engage the reverse gear.

To adjust the guide lines, move the steering wheel to see the changes.

If there is no communication between interface and the vehicle's CAN-bus (several vehicles aren't compatible), the reverse gear guide-lines can't be shown during the vehicle's operation, even if they once appear after having switched the system to powerless!

## 3. Interface operation

### 3.1. By keypad

The external keypad of the can be used to switch alle enabled inputs except the input defined for rear-view camera.

➤ **Long press of keypad (2-3 seconds)**

Long press of external keypad (2-3 seconds), switches from factory video to inserted first enabled interface video-input. Any additional long press switches to the next enabled interface video-input and after last back to factory video. Disabled inputs are skipped. If all inputs are enabled by the corresponding dip-switches, the order is as follows:

➤ *Factory video → V1-Left → V2-Right → factory video*



**Note:** The interface only switches after releasing the switch (after long press).

➤ **Short press of keypad (only if dip 3 is set to ON)**

Short press of external keypad, switches from any video mode to front camera input V3-Front and next short press switches back to the previous video mode.



**Note:** We recommend to install the external keypad for possible support reasons even if not required for customer needs. Make sure the external keypad is not installed “pressed” then.

## 3.2. By factory infotainment buttons

switching video sources

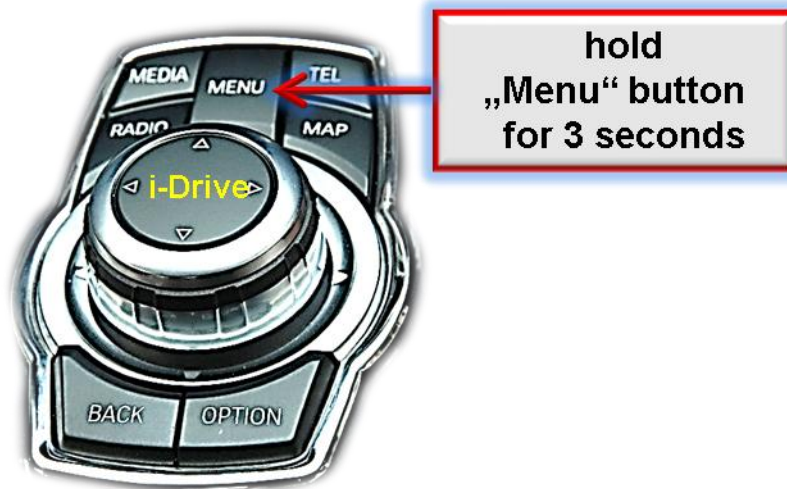

Instead of long pressing the external keypad, the MENU button of the iDrive can be long pressed to switch to V1-Left and V2-Right. Switching to V3-Front is not possible by iDrive.

By pressing the OPTION button for 10 seconds, the interface can be reset in case there is problems with the video on the factory monitor (e.g., black screen).

**Switching by vehicle buttons is not possible in all vehicles. In some vehicles the external keypad has to be used.**

## 4. Specifications

|                      |                               |
|----------------------|-------------------------------|
| BATT/ACC range       | 7V - 16V                      |
| Stand-by power drain | 2mA                           |
| Power                | 260mA @12V                    |
| Video input          | 0.7V - 1V                     |
| Video input formats  | NTSC                          |
| Temperature range    | -40°C to +85°C                |
| Dimensions video-box | 112 x 22 x 115 mm (W x H x D) |

## 5. FAQ – Trouble shooting Interface functions

For any troubles which may occur, check the following table for a solution before requesting support from your vendor.

| Symptom  | Reason  | Possible solution   |
|--|---|---|
| No picture/black picture (factory picture).  | Not all connectors have been reconnected to factory head-unit or monitor after installation.          | Connect missing connectors.   |
|  | No power on CAN-bus box (all LED CAN-bus box are off).  | Check power supply of CAN-bus box. Check CAN-bus connection of CAN-bus box.   |
|  | CAN-bus box connected to CAN-bus in wrong place.  | Refer to the manual where to connected to the CAN-bus. If not mentioned, try another place to connect to the CAN-bus.   |
|  | No power on video-interface (all LED video-interface are off).  | Check whether CAN-bus box delivers +12V ACC on red wire output of 8pin to 6pin cable. If not cut wire and supply ACC +12V directly to video-interface.                              |
| No picture/black picture/white picture (inserted picture) but factory picture is OK. | No picture from video source.   | Check on other monitor whether video source is OK.  |
|  | No video-source connected to the selected interface input.  | Check settings dips 1 to 3 of video interface which inputs are activated and switch to corresponding input(s).  |
|  | LVDS cables plugged in wrong place.   | Double-check whether order of LVDS cables is exactly connected according to manual. Plugging into head-unit does not work when the manual says to plug into monitor and vice versa. |
|  | Wrong monitor settings of video-interface.  | Try different combinations of dips 7 and 8 of video-interface. Unplug 6pin power after each change.   |
| Inserted picture totally wrong size or position.                                     | Wrong monitor settings of video-interface.  | Try different combinations of dips 7 and 8 of video-interface. Unplug 6pin power after each change.   |
| Inserted picture double or 4 times on monitor.                                       |   |   |
| Inserted picture distorted, flickering or running vertically.                        | Video sources output set to AUTO or MULTI which causes a conflict with the interfaces auto detection. | Set video source output fixed to PAL or NTSC. It is best to set all video sources to the same standard.   |
|  | If error occurs only after source switching: Connected sources are not set to the same TV standard.   | Set all video sources to the same standard.   |
|  | Some interfaces can only handle NTSC input.   | Check manual whether there is a limitation to NTSC mentioned. If yes, set source fixed to NTSC output.  |
| Inserted picture b/w.  | Picture settings have not been adjusted.  | Use the 3 buttons and the interface's OSD to adjust the picture settings for the corresponding video input.   |
| Inserted picture qual. bad.  |   |   |
| Inserted picture size slightly wrong.  |   |   |
| Inserted picture position wrong.   |   |   |
| Camera input picture flickers.   | Camera is being tested under fluorescent light which shines directly into the camera.                 | Test camera under natural light outside the garage.   |
| Camera input picture is bluish.  | Protection sticker not removed from camera lens.  | Remove protection sticker from lens.  |

| Symptom   | Reason  | Possible solution  |
|---|---|--|
| Camera input picture black.   | Camera power taken directly from reverse gear lamp.                         | Use relay or electronics to "clean" reverse gear lamp power. Alternatively, if CAN-bus box is compatible with the vehicle, camera power can be taken from green wire of 6pin to 8pin cable.  |
| Camera input picture has distortion.                                    |   |  |
| Camera input picture settings cannot be adjusted.                       | Camera input picture settings can only be adjusted in AV2 mode.             | Set dip 3 of video-interface to ON (if not input AV2 is not already activated) and connect the camera to AV2. Switch to AV2 and adjust settings. Reconnect camera to camera input and deactivate AV2 if not used for other source. |
| Graphics of a car in camera input picture.                              | Function PDC is ON in the interface OSD.                                    | In compatible vehicles, the graphics will display the factory PDC distance. If not working or not wanted, set interface OSD menu item UI-CNTRL to ALLOFF.  |
| Chinese signs in camera input picture                                   | Function RET or ALL is ON (function for Asian market) in the interface OSD. | Set interface OSD menu item UI-CNTRL to ALLOFF or PDCON.   |
| Not possible to switch video sources by OEM button.                     | CAN-bus interface does not support this function for vehicle.               | Use external keypad or cut white wire of 6pin to 8pin cable and apply +12V impulses for AV-switching.  |
| Not possible to switch video sources by external keypad.                | Pressed too short.  | For video source switching a longer press of about 2.5 seconds is required.  |
|   | SW-version of interface does not support external keypad.                   | Use OEM-button or cut white wire of 6pin to 8pin cable and apply +12V impulses for AV-switching.   |
| Interface does not switch to camera input when reverse gear is engaged. | CAN-bus interface does not support this function for the vehicles.          | Cut the green wire of the 6pin to 8pin cable and apply +12V constant from reverse gear-lamp signal. Use relay to "clean" R-gear lamp power.  |
| Interface switches video-sources by itself.                             | CAN-bus interface compatibility to vehicle is limited.                      | Cut the grey wire of 6pin to 8pin and isolate both ends. If problem still occurs, additionally cut the white wire of 6pin to 8pin cable and isolate both ends.   |

## 6. Technical Support

Please note that direct technical support is only available for products purchased directly from NavLinkz GmbH. For products bought from other sources, contact your vendor for technical support.

**NavLinkz GmbH**  
**distribution/tech dealer-support**  
 Heidberghof 2  
 D-47495 Rheinberg

Tel +49 2843 17595 00  
 Email mail@navlinkz.de



Made in China