

## Video-inserter

### RL4-SY3



examples

#### Compatible with Ford vehicles

with Sync3 full version with APIM

with 7inch or 8inch, tablet or non-tablet monitor

with Sync2.5 (Sync3 light/R5) version

with 6.5inch, 7 inch or 8inch tablet monitor

with Sync Connected Radio with 4inch monitor

with Sync4 full version with APIM with horizontal 8inch  
and vertical 10.1inch monitor

Video-inserter for front- and rear-view camera  
and two additional video sources

#### Product features

- Video-inserter for factory-infotainment systems
- 1 CVBS Input for rear-view camera
- 1 CVBS Input for front camera
- 2 CVBS video-inputs for after-market devices (e.g. USB-Player, DVB-T2 tuner)
- Automatic switching to rear-view camera input on engagement of the reverse gear
- Automatic front camera switching after reverse gear for 10 seconds
- Activatable driving-path lines for rear-view camera (not available for all vehicles)
- Activatable PDC (not available for all vehicles)
- Video-in-motion (ONLY for connected video-sources)
- Video-inputs NTSC compatible

## Contents

### 1. Prior to installation

- 1.1. Delivery contents
- 1.2. Checking the compatibility of vehicle and accessories
- 1.3. Connectors – video interface
- 1.4. Dip switch settings
  - 1.4.1. 8 dip – black
    - 1.4.1.1. Activating the front camera input (dip 1)
    - 1.4.1.2. Enabling the interface's video inputs (dip 2-3)
    - 1.4.1.3. Activation of the Interface PDC Graphic (Dip 4)
    - 1.4.1.4. Rear-view camera setting (dip 5)
    - 1.4.1.5. Activating the driving-path lines (dip6)
    - 1.4.1.6. Monitor selection (Dip 7)
    - 1.4.1.7. Head-unit version (dip8)
  - 1.4.2. 4 dip - red

### 2. Installation

- 2.1. Place of installation
- 2.2. Connection schema
- 2.3. Connection - Sync3 and Sync4 full version as ALL-IN-ONE head-unit
  - 2.3.1. Connection picture signal cable
  - 2.3.2. Connection PNP Power / CAN cable
- 2.4. Connection – Sync3 and Sync4 full version with tablet monitor and separate APIM module
  - 2.4.1. Connection picture signal cable
  - 2.4.2. Connection PNP Power / CAN cable
- 2.5. Special case: Sync2.5 (Sync3 light/R5) version with 6.5inch or 8inch tablet monitor and radio module with HSD + Sync Connected Radio version with 4inch monitor
- 2.6. Installation with analogue connection (without CAN bus)
- 2.7. Power supply output

### 3. Connection – video sources

- 3.1. Audio insertion
- 3.2. After market front camera
- 3.3. After-market rear-view camera
  - 3.3.1. Case 1: Interface receives the reverse gear signal
  - 3.3.2. Case 2: Interface does not receive the reverse gear signal
- 3.4. Connecting video-interface and keypad
- 3.5. Picture settings

### 4. Interface operation

- 4.1. By infotainment button
- 4.2. By keypad

### 5. Specifications

### 6. FAQ – Trouble Shooting-Interface functions

### 7. Technical support

## Legal Information

By law, watching moving pictures while driving is prohibited, the driver must not be distracted. We do not accept any liability for material damage or personal injury resulting, directly or indirectly, from installation or operation of this product. Apart from using this product in an unmoved vehicle, it should only be used to display fixed menus or rear-view-camera video when the vehicle is moving (for example the MP3 menu for DVD upgrades).

Changes/updates of the vehicle's software can cause malfunctions of the interface. Up to one year after purchase we offer free software-updates for our interfaces. To receive a free update, the interface has to be sent in at own cost. Wages for de-and reinstallation and other expenditures involved with the software-updates will not be refunded.

## 1. Prior to installation

Please read the manual thoroughly BEFORE starting the installation. Technical knowledge is imperatively required. The place of installation has to be free of moisture and away from heat sources.

### 1.1. Delivery contents

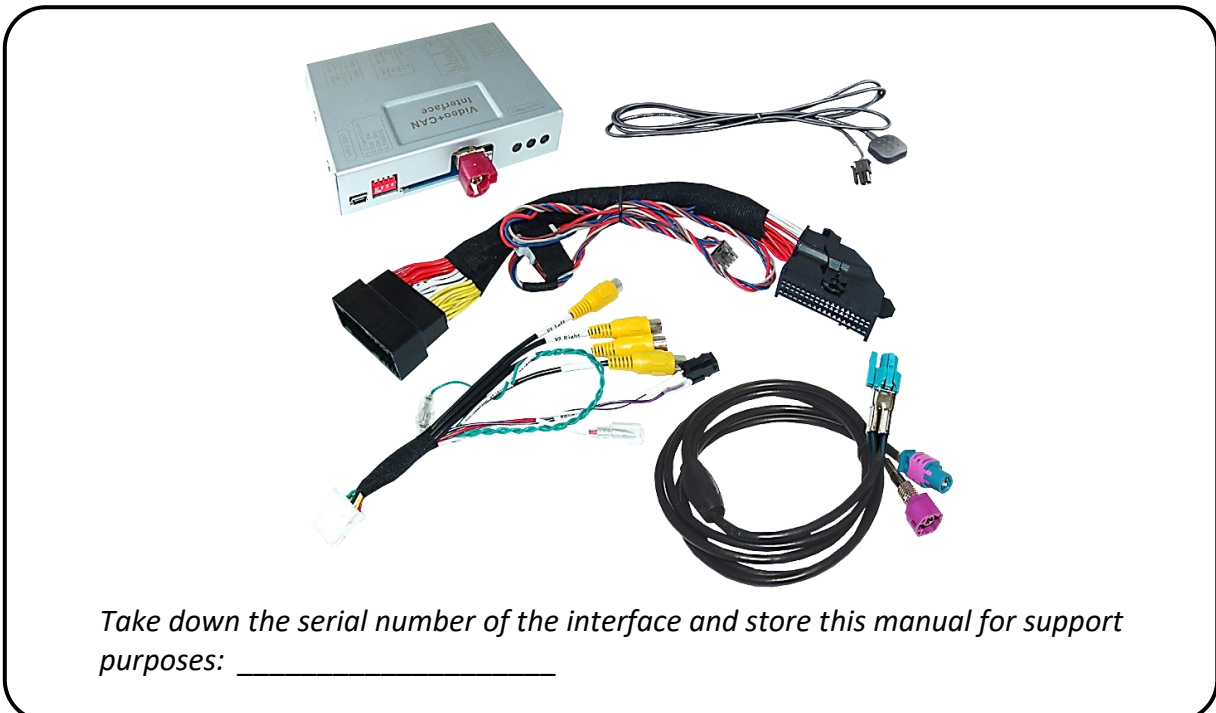

## 1.2. Checking the compatibility of vehicle and accessories

### Compatibility

Brand	Compatible vehicles	Infotainment systems
Ford	<b>C-Max</b> since model year 2018 <b>Ecosport</b> since model year 2017 <b>Fiesta</b> since model year 2018 til 07/2017 <b>Focus</b> model years 2017 til 2021 <b>Galaxy</b> since model year 2016 <b>Kuga2 Facelift</b> about 09/2016 til 11/2019 <b>Kuga3</b> 11/2019 til 05/2024 <b>Mondeo</b> since model year 2017 <b>Mustang6</b> since 08/2017 til 04/2023 <b>Puma2</b> <b>Ranger</b> since 08/2016 til 02/2023 <b>S-Max</b> since model year 2016 <b>Tourneo Custom</b> from 2018 til 07/2023 <b>Transit</b> since model year 2017 <b>Transit Custom</b> since facelift 2018 til 07/2023 and other vehicles with	Sync3 full version with APIM and with 7inch or 8inch tablet or non-table monitor – <b>Plug &amp; Play installation</b>
		Sync2.5 (Sync3 light/R5) version with 6.5inch, 7inch or 8inch tablet monitor – <b>Non Plug &amp; Play installation. For Plug &amp; Play the RL4-SY3-R5 is available)</b>
		Sync Connected Radio with 4inch monitor – <b>Non Plug &amp; Play installation. For Plug &amp; Play the RL4-SY3-R5 is available)</b>
	<b>Tourneo Courier</b> since 10/2023 <b>Transit Courier</b> since 10/2023	Sync4 full version with APIM with horizontal 8inch monitor
	<b>Ranger</b> since 11/2022  <i>Not compatible with Sync4 with vertical 12inch monitor. The HDV-SY4 is the appropriate interface for this.</i>	Sync4 full version eith APIM eith vertical 10.1inch monitor  <i>from SW 25_2.0/GD1.0/90C52_1.0/GW256_2.0</i>

### Limitations

<i>Video only</i>	The interface inserts ONLY video signals into the infotainment. For inserting Audio signals either the possibly existing factory audio-AUX-input or a FM-modulator can be used. In case that 2 AV sources shall be connected, a desired audio switching will require additional electronic.
<i>Inserted video picture at vertical monitors</i>	To ensure a better picture quality, the inserted video picture is displayed on the upper half of the monitor (only Ford Ranger with Sync4 and vertical 10.1inch monitor).
<i>Factory rear-view camera</i>	Automatically switching-back from inserted video to factory rear-view camera is only possible while the reverse gear is engaged. To delay the switch-back an additional electronic part is required.
<i>After market front camera</i>	The front camera will automatically be switched for 10 seconds after disengaging the reverse gear. A manually front camera switching is possible by external keypad.
<i>Driving-path lines and PDC</i>	Displayed driving-path lines and the optical PDC are not available in all vehicles.
Video input signal	NTSC video sources compatible only.

## 1.3. Connectors – video interface

The video-interface converts the video signals of connected after-market sources in a factory monitor compatible picture signal which is inserted in the factory monitor, by using separate trigger options. Further it reads the vehicle's digital signals out of the vehicle's CAN-bus and converts them for the video interface.

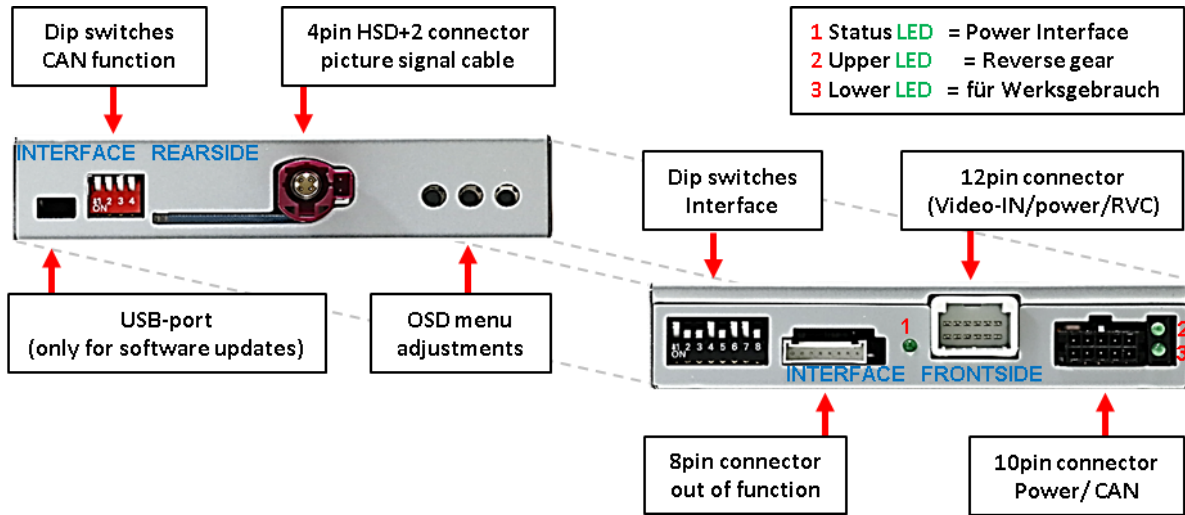

## 1.4. Dip-switch settings

### 1.4.1. 8 dip - black

Some settings have to be selected by the dip-switches on the video interface.

Dip position down is ON and position up is OFF.



Dip	Function	ON (down)	OFF (up)
1	Front camera	enabled*	disabled
	Power supply output (red wire)	+12V (max. 3A) when reverse gear is engaged incl. 10 seconds delay and +12V by manual switching to front camera by keypad	+12V (max. 3A) ACC
2	CVBS AV1-input	enabled	disabled
3	CVBS AV2-input	enabled	disabled
4	PDC	enabled	disabled
5	Rear-view cam type	after-market	factory or none
6	Driving-path lines	enabled	disabled
7	Monitor selection	4inch monitor	6.5/7/8/10.1inch monitor
8	Head-unit version	all versions	Sync3 exceptions

\*The front camera will automatically be switched for 10 seconds after disengaging the reverse gear.

**After each Dip-switch-change a power-reset of the Video Interface has to be performed!**

See the following chapters for detailed information.

## 1.4.1.1. Activating the front camera input (dip 1)

If set to ON, the interface switches for 10 seconds from the rear-view camera to the front camera input after having disengaged the reverse gear. In addition, a manual switch-over to the front camera input is possible via keypad (short press) from any image mode.

Description of the power supply output: see chapter "Power supply output".

## 1.4.1.2. Enabling the interface's video inputs (dip 2-3)

Only the enabled video inputs can be accessed when switching through the interface's video sources. It is recommended to enable only the required inputs, disabled inputs will be skipped when switching through the video-interfaces inputs.

## 1.4.1.3. Activation of the Interface PDC Graphic (Dip 4)

Dip 4 is used to display the interface PDC graphic as „picture in picture“ in combination with the camera image.

## 1.4.1.4. Rear-view camera setting (dip 5)

If set to OFF, the interface switches to factory picture while the reverse gear is engaged to display factory rear-view camera.

If set to ON, the interface switches to its rear-view camera input „**Camera-IN**“ while the reverse gear is engaged.

## 1.4.1.5. Enabling the driving-path lines (dip 6)

If set to ON, the interface is activated to show the driving-path lines for the rear-view camera while the vehicle is in reverse mode (not available for all vehicles).



**Note:** Some vehicles have a different code on the CAN-bus which the video-interface is not compatible with. If the interface does not communicate completely with the vehicle CAN bus, the reverse gear driving-path lines and the PDC can't be shown during the vehicle's operation, even if they in some vehicles once appear after having switched the system to powerless!

## 1.4.1.6. Monitor selection (Dip 7)

Dip 7 is used to adjust to the corresponding monitor size. If set to **ON**, 4 inch monitors are selected on the interface. If set to **OFF**, 6.5, 7, 8 and 10.1inch monitors are selected on the interface.

## 1.4.1.7. Head-unit version (dip 8)

The general dip switch setting for all head unit versions is **ON**.

However, there are a few versions that show a black image in the video inputs, which can be restored by setting the switch to **OFF**. In this case, however, an approx. 3mm thick stripe could possibly remain on the left side (see also picture settings).

**After each Dip-switch-change a power-reset of the Video Interface has to be performed!**

## 1.4.2. 4 dip - red

By using the red Dip-switches, the factory Head-unit or vehicle can be chosen which the interface will be connected to.

Dip position down is ON and position up is OFF.



Vehicle/Navigation	Dip 1	Dip 2	Dip 3	Dip 4
Ford up to MY 2018	ON	OFF	Sync 3 light (R5) ON Sync 3/4 full version OFF	OFF
Ford from MY 2019 (Tablet)	ON	ON	Sync 3 light (R5) ON Sync 3/4 full version OFF	OFF

**After each Dip-switch-change a power-reset of the Video Interface has to be performed!**

## 2. Installation

**To install the interface, first switch off the ignition and disconnect the vehicle's battery. Please read the owner's manual of the car, regarding the battery's disconnection! If required, enable the car's Sleep-mode (hibernation mode) In case the sleep-mode does not succeed, the disconnection of the battery can be done with a resistor lead.**

**As with any installation of retrofit equipment, a stand-by test is necessary after the installation of the video interface, to ensure that the unit also switches off after reaching the vehicle's sleep mode.**

**Before the final installation, we recommend a test-run of the interface. Due to changes in the production of the vehicle manufacturer, there's always the possibility of incompatibility.**

### 2.1. Place of installation

The place of installation differs for the respective Sync3 and Sync4 versions,

- **Sync3 and Sync4 full version as ALL-IN-ONE Head-Unit**  
Installation location is behind the head unit - with the ALL-IN-ONE head unit, the APIM module is attached as a sandwich to the back of the monitor.
- **Sync3 and Sync4 full version with tablet monitor and separate APIM module**  
Installation location is behind the monitor and on the APIM module  
The APIM module is located depending on the vehicle:
  - behind the centre console e.g., Focus (climate panel must be removed)
  - behind the glove box
  - behind the Tacho unit (e.g., Puma, Ecosport)

**Note:** The radio module is a separate DIN-sized module and is NOT required for installation!



## 2.2. Connection schema

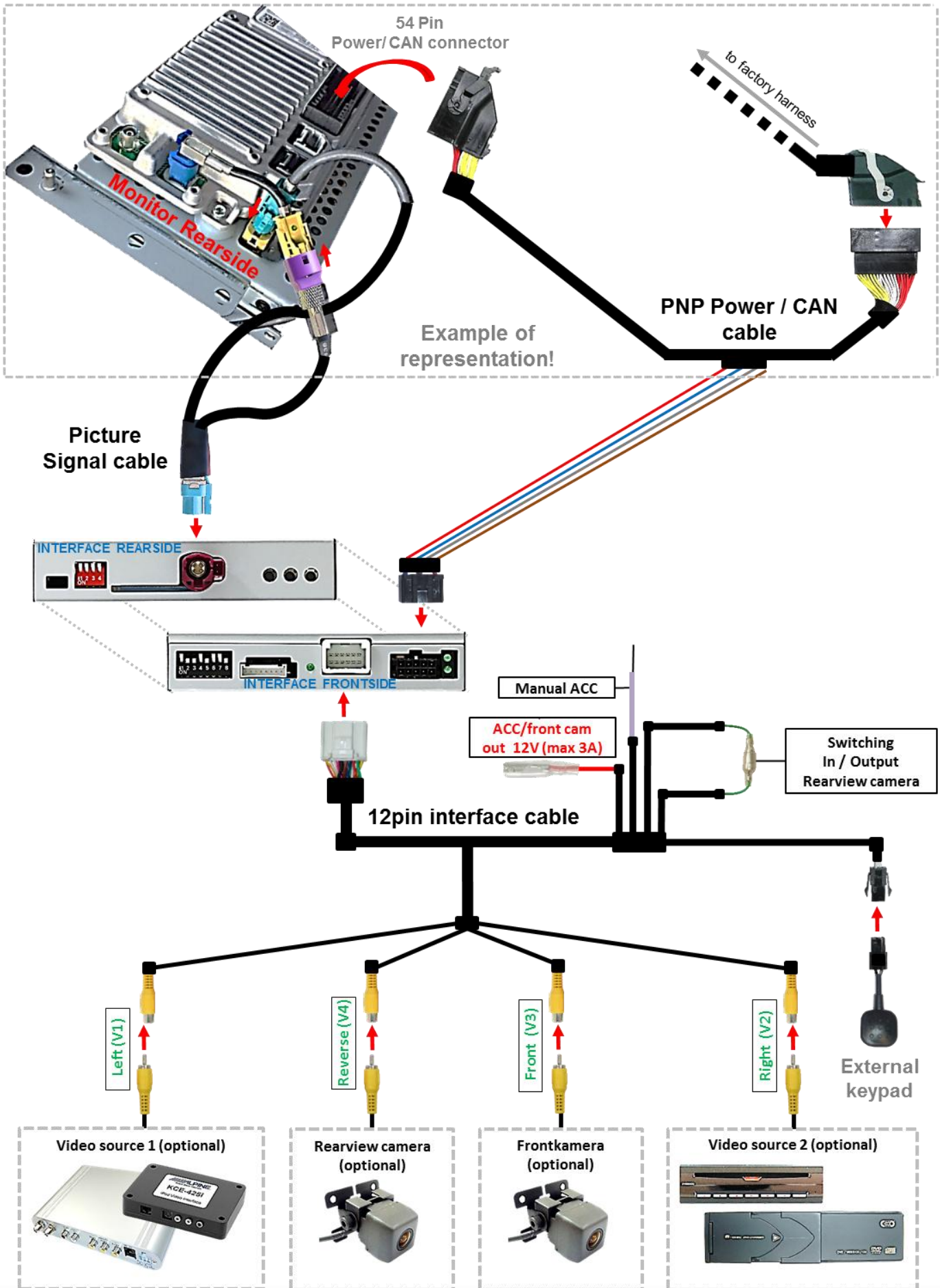

## 2.3. Connection – Sync3 and Sync4 full version as ALL-IN-ONE head-unit

Place of Installation is behind the head unit - **with the ALL-IN-ONE head unit, the APIM module is attached as a sandwich to the back of the monitor.**

**Note:** The radio module is a separate DIN-sized module and is NOT required for installation!



**No liability for vehicle wire colours and pin definition!**

Changes by the vehicle manufacturer are possible.

The given information has to be verified by the installer.

## 2.3.1. Connection picture signal cable

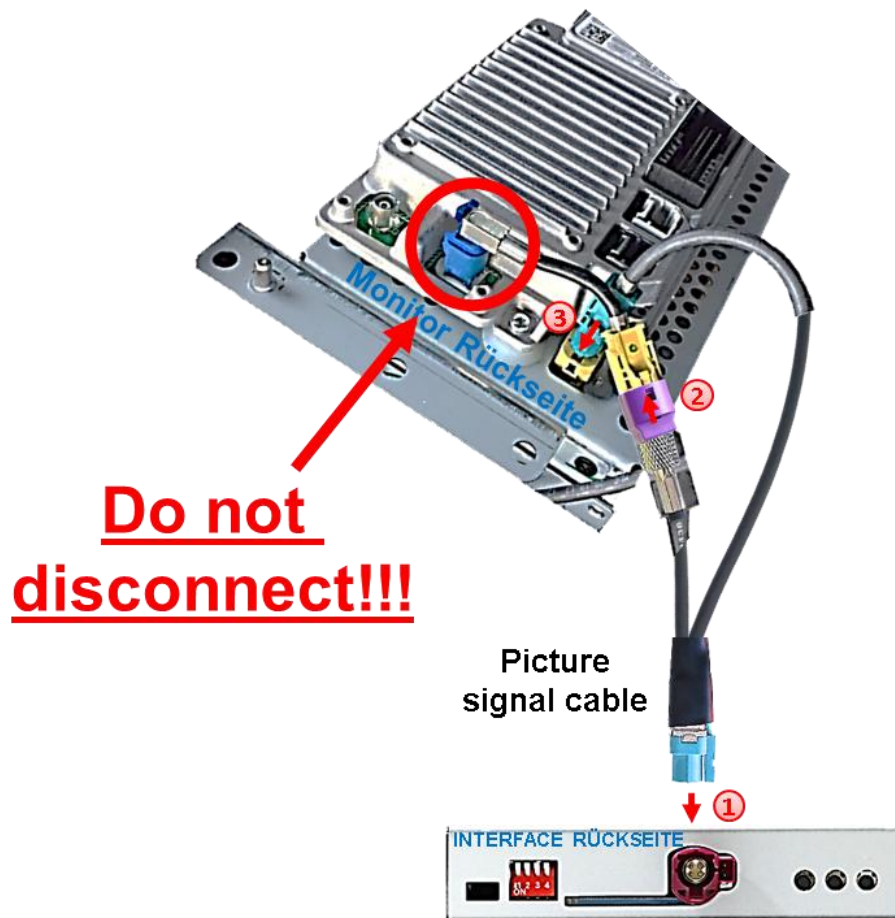

- 1 Connect the female picture signal cable's **WATERBLUE** coloured HSD+2 connector to the male **WATERBLUE** coloured HSD+2 connector of the video interface.
- 2 Disconnect the **CURRY** coloured female 4pin HSD connector of the HSD bridge at the rear side of the monitor and connect it to the male **PURPLE** coloured HSD connector of the enclosed 4pin HSD LVDS cable. Caution: The female blue coloured HSD connector of the HSD bridge must never be disconnected from the monitor's rear side!
- 3 Connect the female **WATERBLUE** coloured HSD connector of the enclosed 4pin HSD picture signal cable to the previously become free male **CURRY** coloured HSD connector at the monitor's rear side.

**Caution:** The **BLUE** female HSD connection at the monitor HSD bridge has to remain connected in the monitor's rear side during the whole process and **must never be disconnected from its original place.**

The picture signal cable has to be connected to the monitor. **Connection to the head unit may cause damage to the system!**

## 2.3.2. Connection PNP power / CAN cable

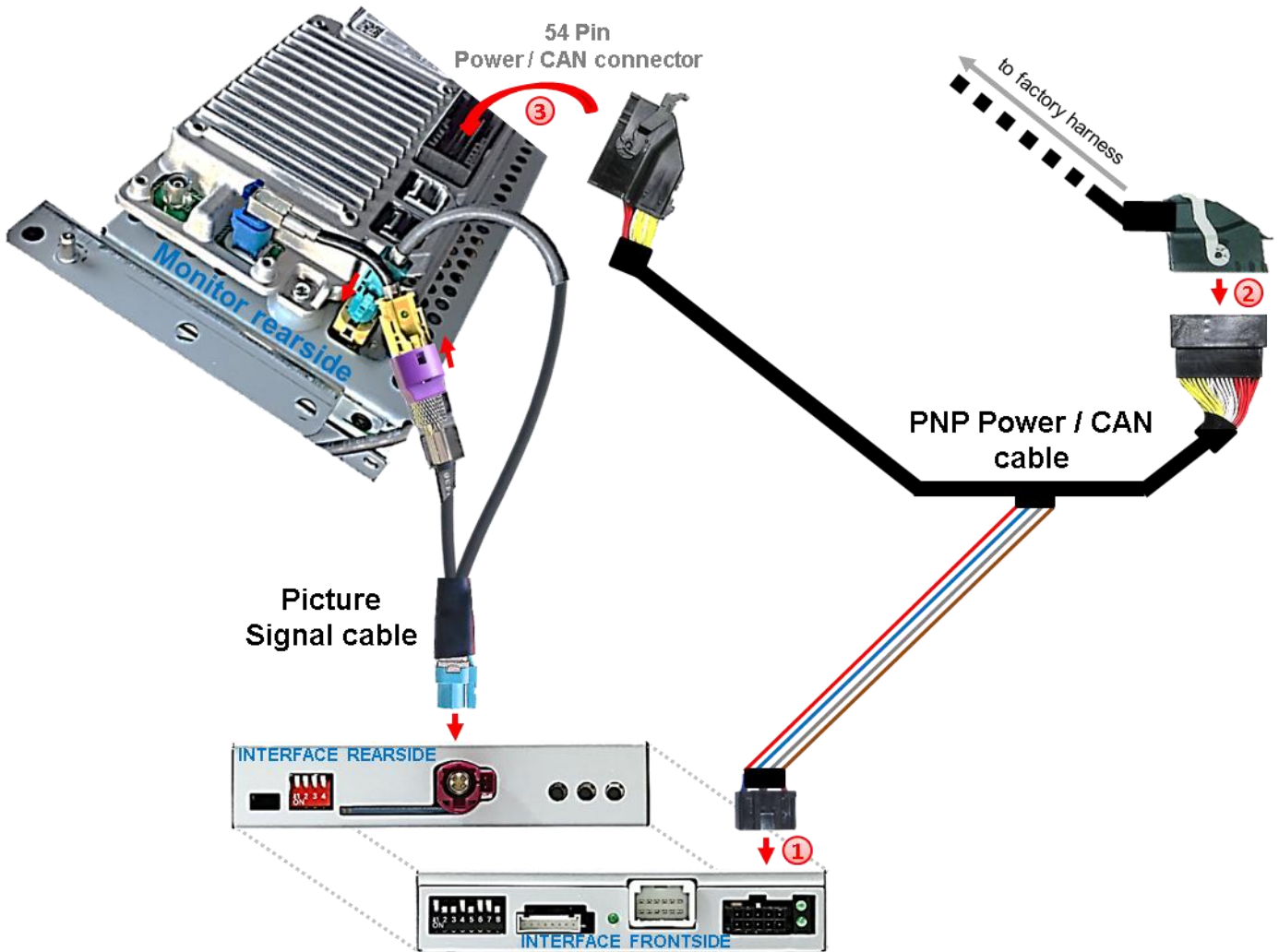

- 1 Connect the enclosed PNP Power / CAN cable's female 10pin connector to the male 10pin connector of the video interface.
- 2 Disconnect the female 54pin connector of the vehicle harness at the rear side of the monitor and connect it to the male 54pin connector of the enclosed PNP Power/CAN cable.
- 3 Connect the enclosed PNP Power / CAN cable's opposite female 54pin connector to the previously become free male 54pin connector of the monitor.

### Check 1

*Exceptionally, the CAN communication may not succeed in all vehicles! If, after connecting the PNP harness, no interface LED lightens up while the ignition is turned on, additionally the analog power supply needs to be done! (see following chapter)*



### Check 2

*Exceptionally, the power supply to the video interfaces may not be interrupted after switching to the vehicle's sleep mode. If the interface LEDs continue to shine even in the vehicle's sleep mode, please contact the support!*

## 2.4. Connection – Sync3 and Sync4 full version with tablet monitor and separate APIM module

Place of Installation is behind the monitor and on the APIM module - **the APIM module is located behind the centre console or behind the glove box.**

**Note:** The radio module is a separate DIN-sized module and is NOT required for installation!

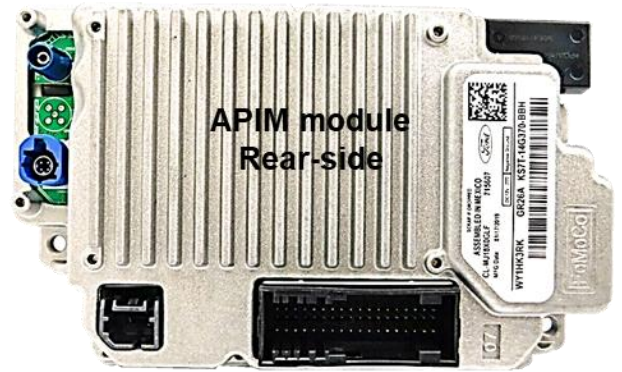
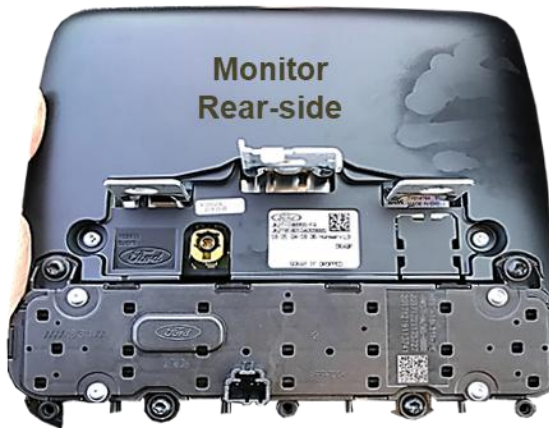

**No liability for vehicle wire colours and pin definition!**  
Changes by the vehicle manufacturer are possible.  
The given information has to be verified by the installer.

## 2.4.1. Connection picture signal cable

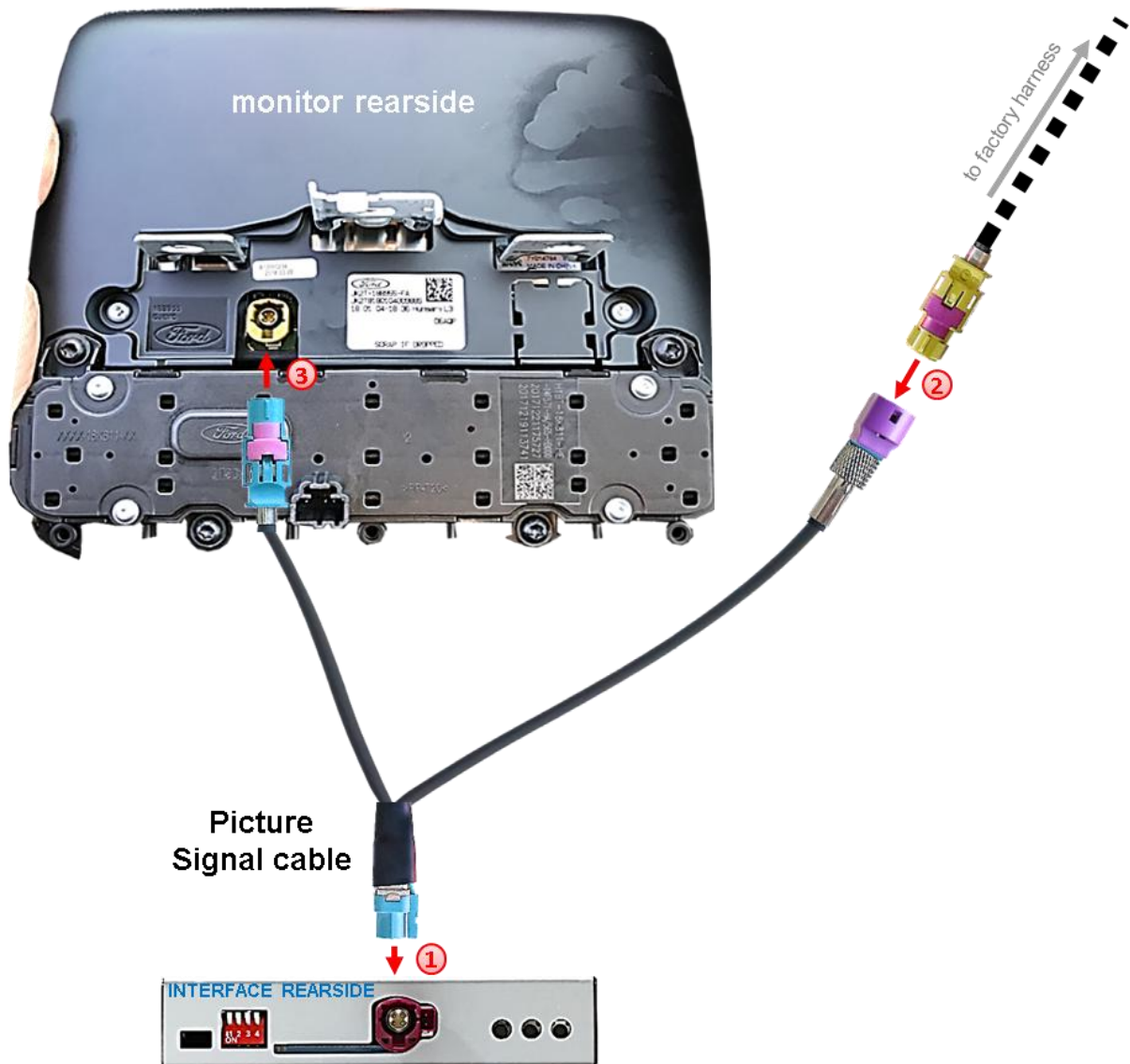

- ① Connect the female picture signal cable's **WATERBLUE** coloured HSD+2 connector to the male **WATERBLUE** coloured HSD+2 connector of the video interface.
- ② Disconnect the **CURRY** coloured female 4pin HSD connector of the factory harness at the rear side of the monitor and connect it to the male **PURPLE** coloured HSD connector of the enclosed 4pin HSD LVDS cable.
- ③ Connect the female **WATERBLUE** coloured HSD connector of the enclosed 4pin HSD picture signal cable to the previously become free male **CURRY** coloured HSD connector at the monitor's rear side.

Caution: The picture signal cable has to be connected to the monitor. **Connection to the head unit may cause damage to the system!**

## 2.4.2. Connection PNP power / CAN cable

The APIM module is located behind the centre console or behind the glove box.

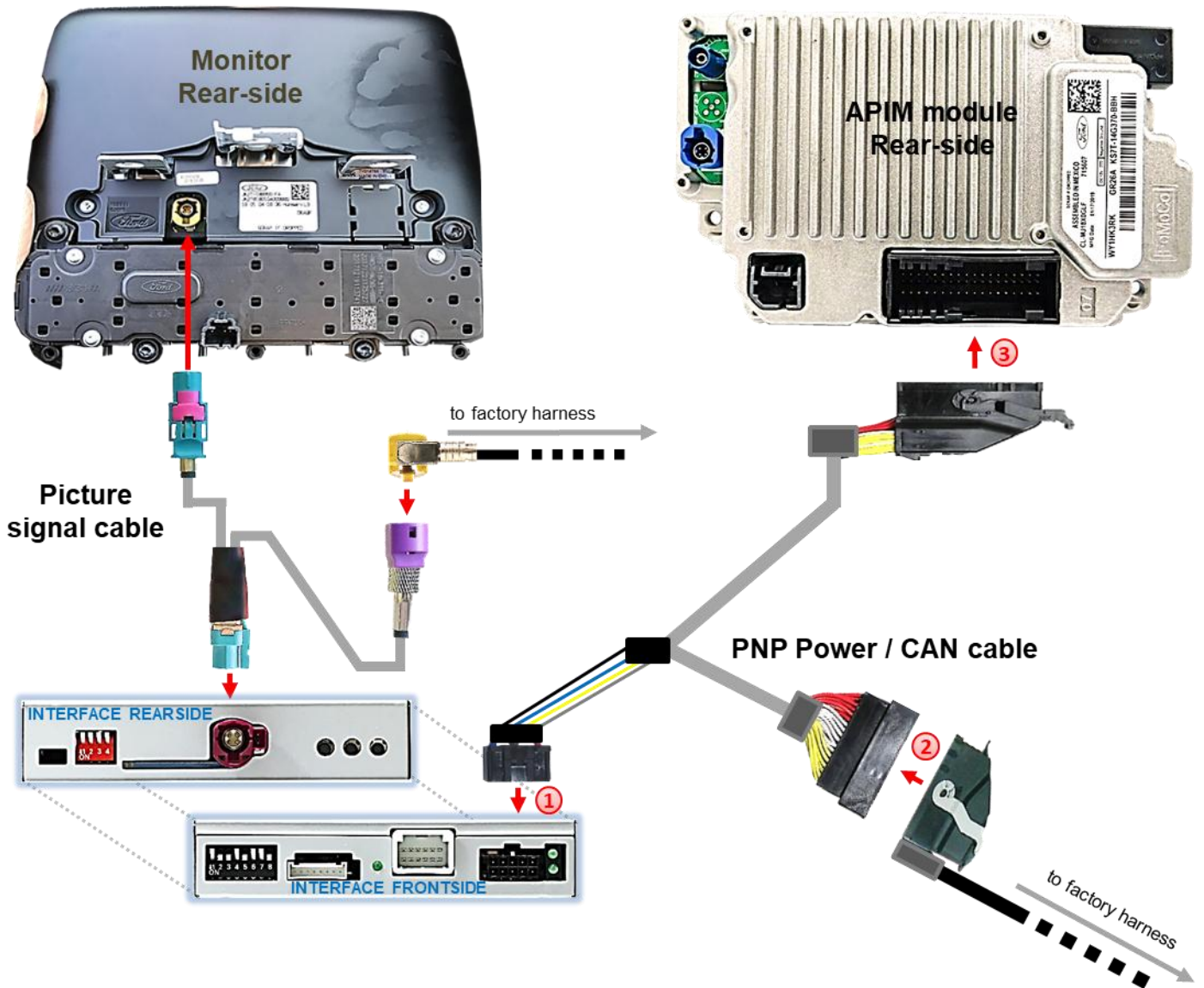

- ① Connect the enclosed PNP Power / CAN cable's female 10pin connector to the male 10pin connector of the video interface.
- ② Disconnect the female 54pin connector of the vehicle harness at the rear side of the APIM module and connect it to the male 54pin connector of the enclosed PNP Power/CAN cable.
- ③ Connect the enclosed PNP Power / CAN cable's opposite female 54pin connector to the previously become free male 54pin connector of the APIM module.

### Check 1

*Exceptionally, the CAN communication may not succeed in all vehicles! If, after connecting the PNP harness, no interface LED lightens up while the ignition is turned on, additionally the analog power supply needs to be done! (see following chapter)*



### Check 2

*Exceptionally, the power supply to the video interfaces may not be interrupted after switching to the vehicle's sleep mode. If the interface LEDs continue to shine even in the vehicle's sleep mode, please contact the support!*

## 2.5. Special case: Sync2.5 (Sync3 light/R5) version with 6.5inch or 8inch tablet monitor and radio module with HSD + Sync Connected Radio version with 4inch monitor

*Non Plug & Play installation  
For Plug & Play is  
RL4-SY3-R5 available*

**Place of installation:** The picture signal cable is connected behind the monitor. The PNP power / CAN cable is connected to the factory radio module (hidden DIN housing). This is behind/under the monitor in the centre console on most vehicles. There is no APIM-module with these Sync versions.

For connection to the Sync2.5 (Sync3 light/R5) or the Sync Connected Radio infotainment, the PNP Power/CAN cable's 4 single wires have to be cut near the big 54pin harness. The 54pin connection can't be used!



**No liability for vehicle wire colours and pin definition!**

Changes by the vehicle manufacturer are possible.

The given information has to be verified by the installer.

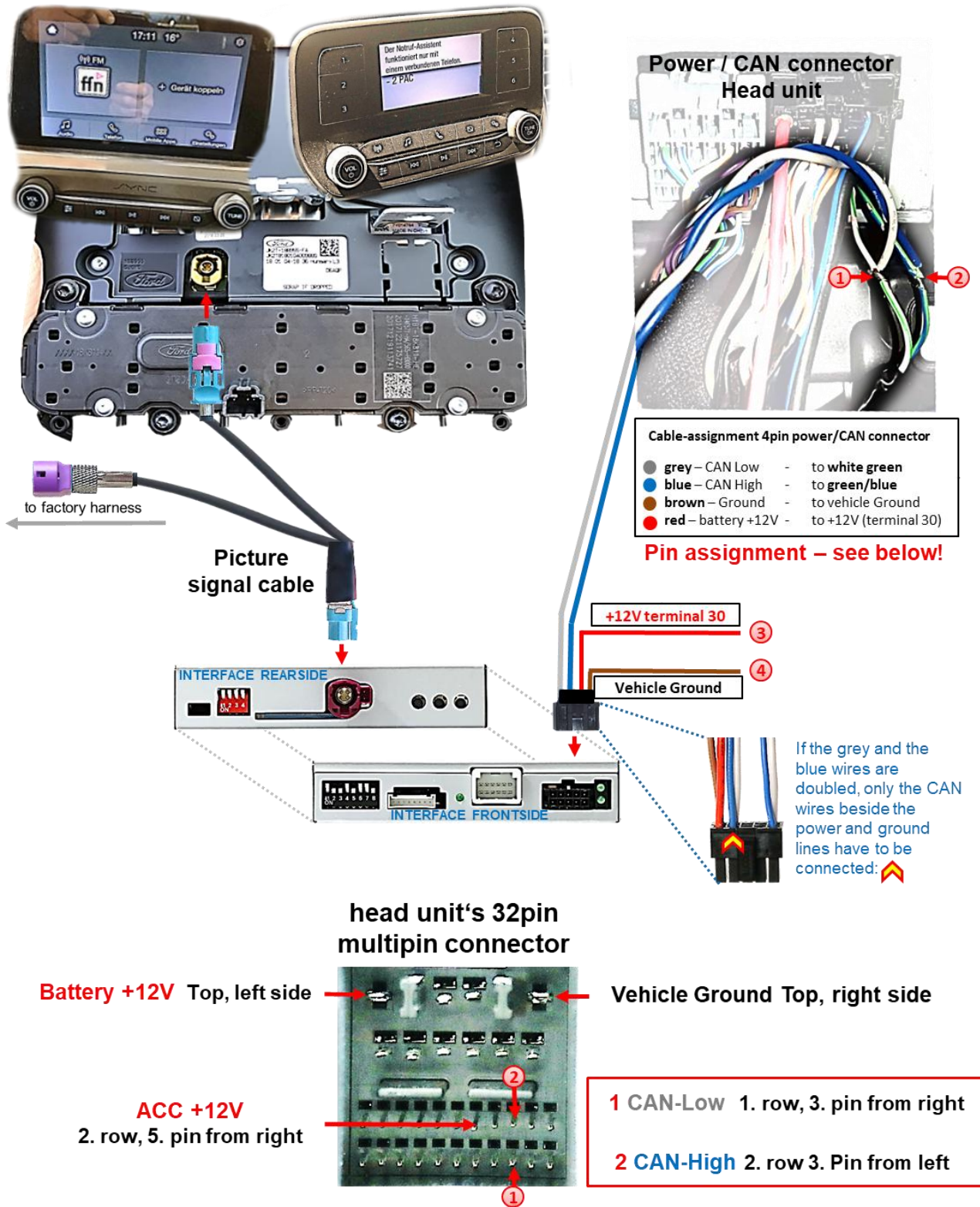

- ① Connect the single grey wire „CAN LOW“ of the 4 cables to the head unit main connector’s white/green cable (bottom/right side) and isolate the connection.
- ② Connect the single blue wire „CAN HIGH“ of the 4 cables to the head unit main connector’s green/blue cable (right beside) and isolate the connection.
- ③ Connect the single red wire to stable **+12V permanent terminal 30**.
- ④ Connect the single brown cable to the vehicle’s **Ground**.

## 2.6. Installation with analogue connection (without CAN bus)

If, after connecting the PNP harness, no interface LED lightens up while the ignition is turned on, the interface must also be connected in analogue mode.

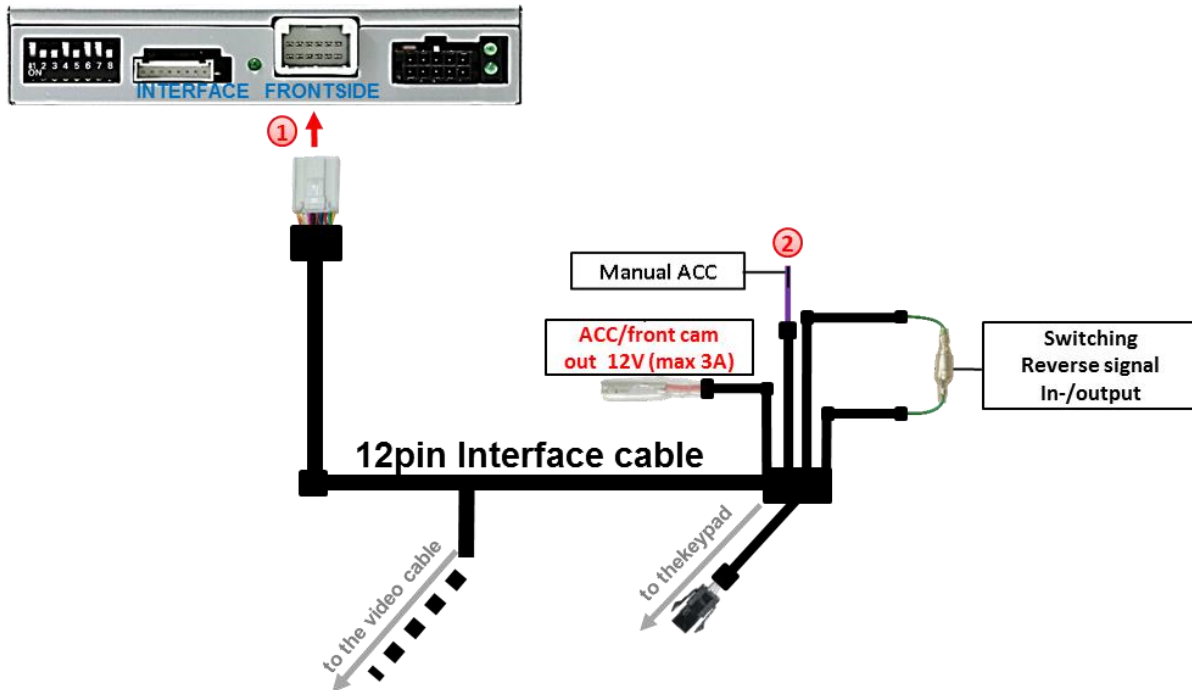

- 1 Connect the female 12pin connector of the 12pin interface cable to the male 12pin connector of the video interface.
- 2 Connect the 12pin interface cable's purple coloured wire **Manual ACC** to **+12V ACC** or to **S-contact terminal 86s +12V** (e.g. glove compartment illumination).

## 2.7. Power supply output

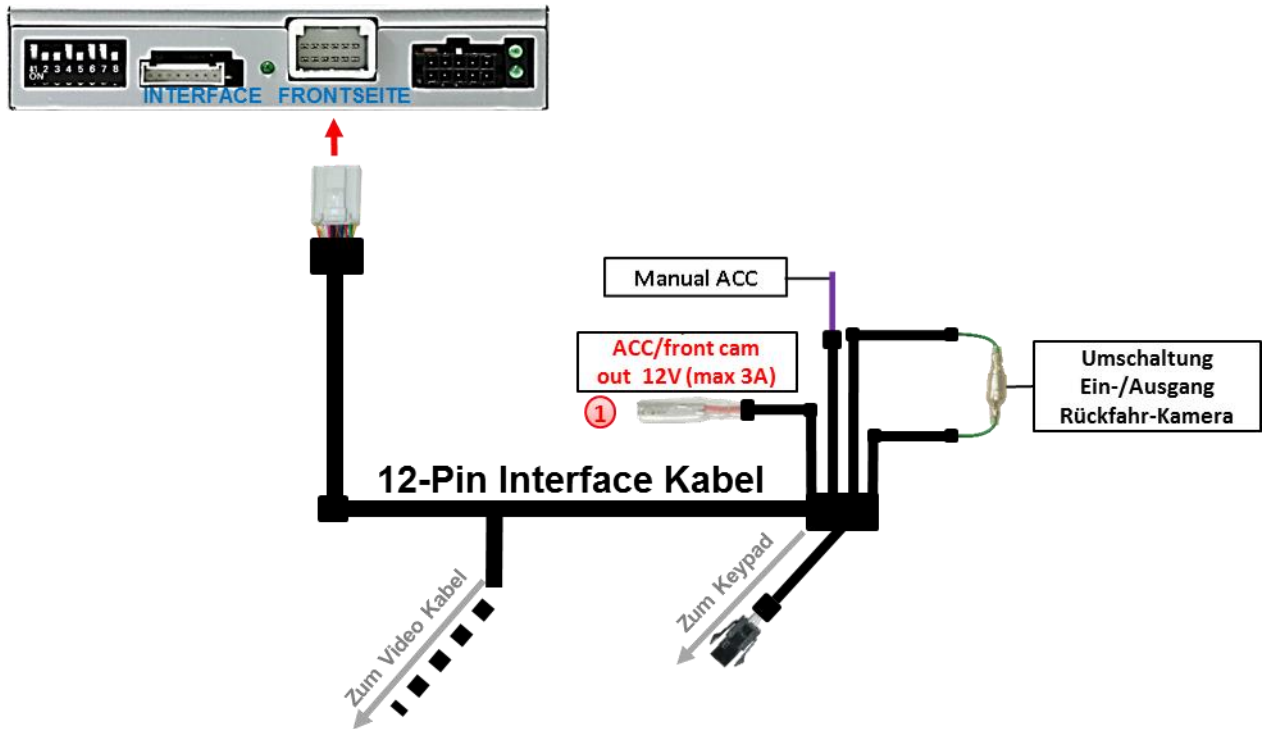

- ① The red power supply output **ACC/front cam out 12V (max 3A)** can be used to power an external source and has a different assignment depending on the position of dip switch 1 (of the black 8 dips):

Dip	Function
Dip 1 <b>ON</b>	+12V (max. 3A) when reverse gear is engaged incl. 10 seconds delay after reverse gear is disengaged and +12V by manual switching to front camera by keypad (short press)
Dip 1 <b>OFF</b>	+12V (max. 3A) ACC

### 3. Connection – Video sources

It is possible to connect an after-market rear-view camera, an after-market front camera and two more video sources to the video-interface.

**Before the final installation, we recommend a test-run to detect a incompatibility of vehicle and interface. Due to changes in the production of the vehicle manufacturer there's always a possibility of incompatibility.**



**Limitations - Only Sync4 with vertical 10.1-inch monitor (Ford Ranger):**

To ensure a better picture quality, the inserted video picture is displayed on the upper half of the monitor (only Ford Ranger with Sync4 and vertical 10.1inch monitor).



Sync4 with vertical 10.1inch monitor

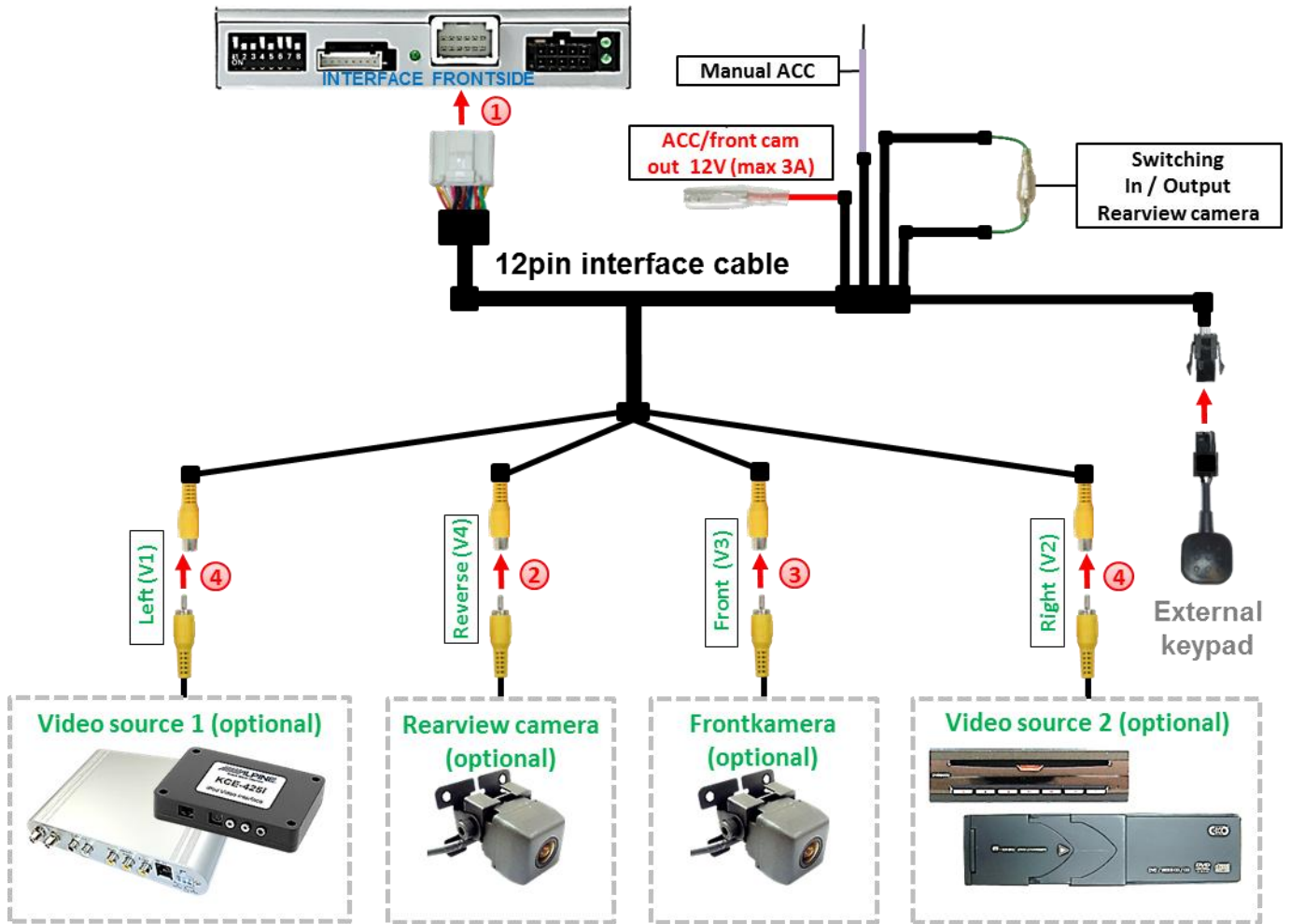

- ① Connect the 12pin interface cable's female 12pin connector to the male 12pin connector of the video-interface.
- ② Connect the video RCA of the Rear-view camera to the 12pin interface cable's female RCA connector „Reverse V4“.
- ③ Connect the front camera's video RCA connector to the 12pin interface cable's female RCA connector „Front V3“.
- ④ Connect the video RCA of the AV source 1 and 2 to the 12pin interface cable's female RCA connector “Left (V1)” and “Right (V2)”.

## 3.1. Audio-insertion

This interface is only able to insert video signals into the factory infotainment. If an AV-source is connected, the audio insertion has to be done by the factory audio AUX input or an FM-modulator. The inserted video-signal can be activated simultaneously to each audio-mode of the factory infotainment. If 2 AV sources shall be connected to the infotainment, additional electronic is necessary to switch the audio signals.

## 3.2. After-market front camera

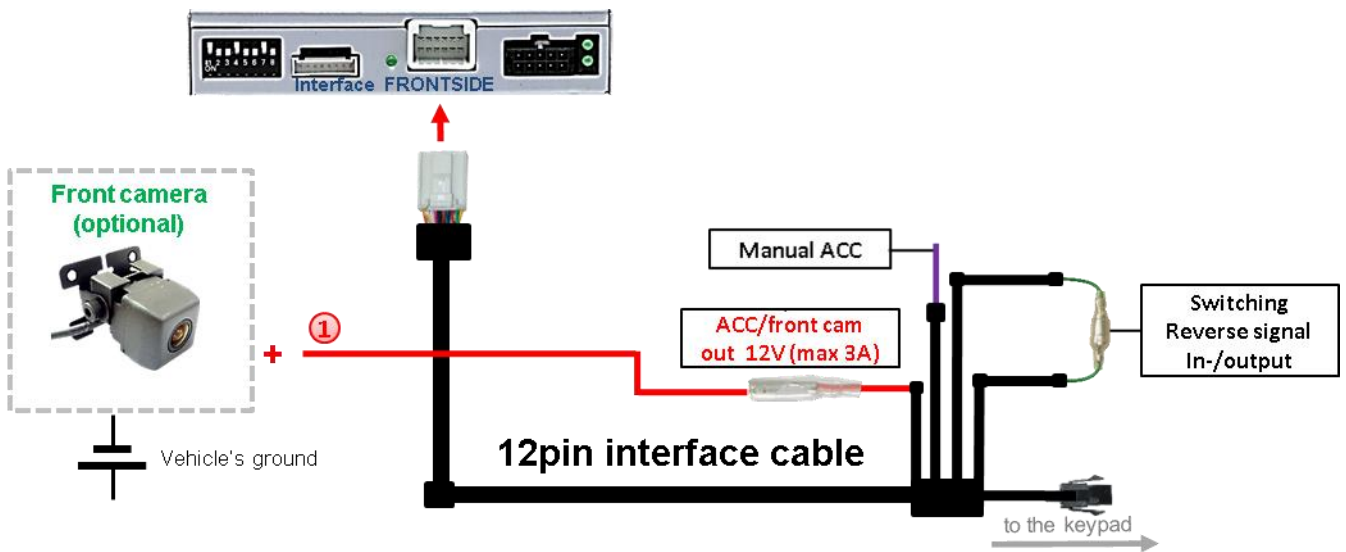

- ① The red power supply output **ACC/front cam out 12V (max 3A)** can be used to power a front camera. If Dip 1 is set to ON (black 8 dips), the power supply output gives +12V (max 3A) when reverse gear is engaged incl. 10 seconds delay after reverse gear is disengaged.

**Note:** In addition, a manual switch-over to the front camera input is possible via keypad (short press) from any image mode. The power supply output gives +12V then, as well (if Dip 1 is set to ON and the front camera input is selected).

Attention: A long press of the external keypad push button will switch the interface to the next source.

### 3.3. After-market rear-view camera

Some vehicles have a different reverse gear code on the CAN-bus which doesn't communicate with the interface's CAN. In this case there are two different ways of installation. If the interface's CAN is able to detect an enabled vehicle's reverse gear, the green wire of the 6pin to 12pin cable should carry +12V while the reverse gear is engaged.

**Note:** Do not forget to set dip5 of video-interface to ON before testing.

#### 3.3.1. Case 1: Interface receives the reverse gear signal

If the interface receives +12V on the green wire of the 12pin interface cable while reverse gear is engaged, the video interface will automatically switch to the rear-view camera input **"CAMERA-IN"** while the reverse gear is engaged.

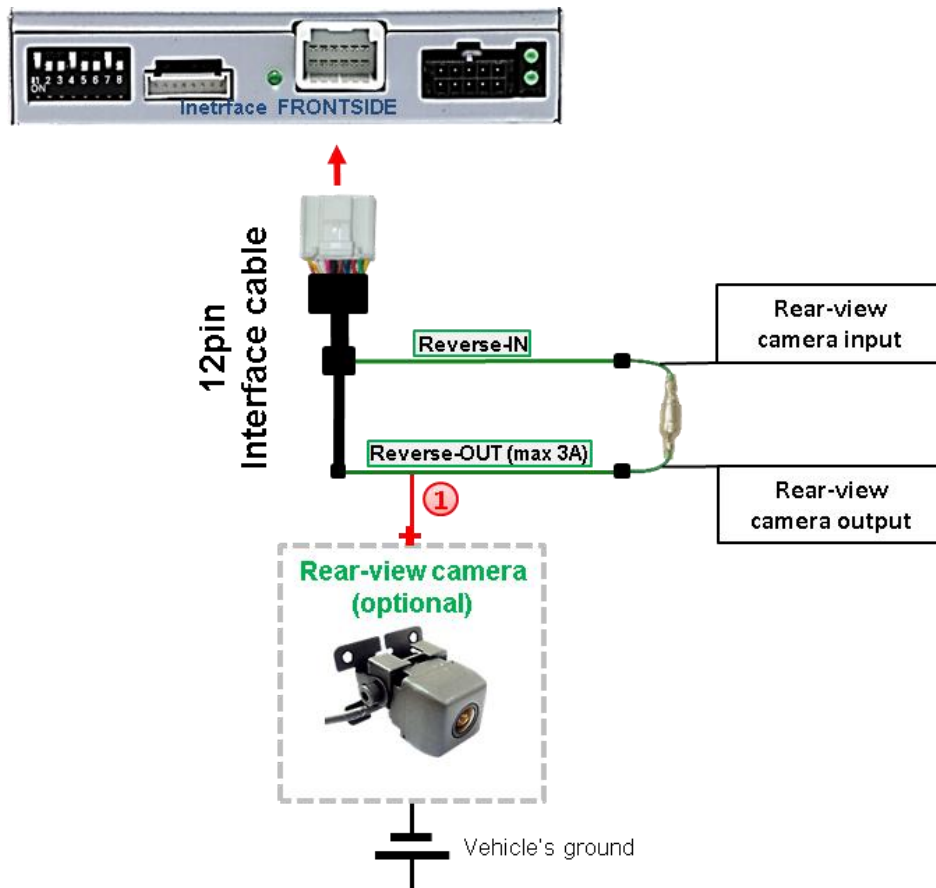

- 1 The 12 V power supply for the rear-view camera (max 3A) has to be taken from the 12pin interface cable's green wire **"Reverse-OUT"** to avoid an unnecessary, permanent power supply to the camera electronic. Both green cables **"Reverse IN"** and **"Reverse OUT"** have to remain connected.

## 3.3.2. Case 2: Interface does not receive the reverse gear signal

If the video interface does not receive +12V on the green wire of the 12pin interface cable when reverse gear is engaged (not all vehicles are compatible), an external switching signal from the reverse gear light is required. As the reverse gear light's power supply isn't voltage-stable all the time, an ordinary open relay (e.g. AC-RW-1230 with wiring AC-RS5) or filter (e.g. AC-PNF-RVC) is required. The diagram below shows the connection type of the relay.

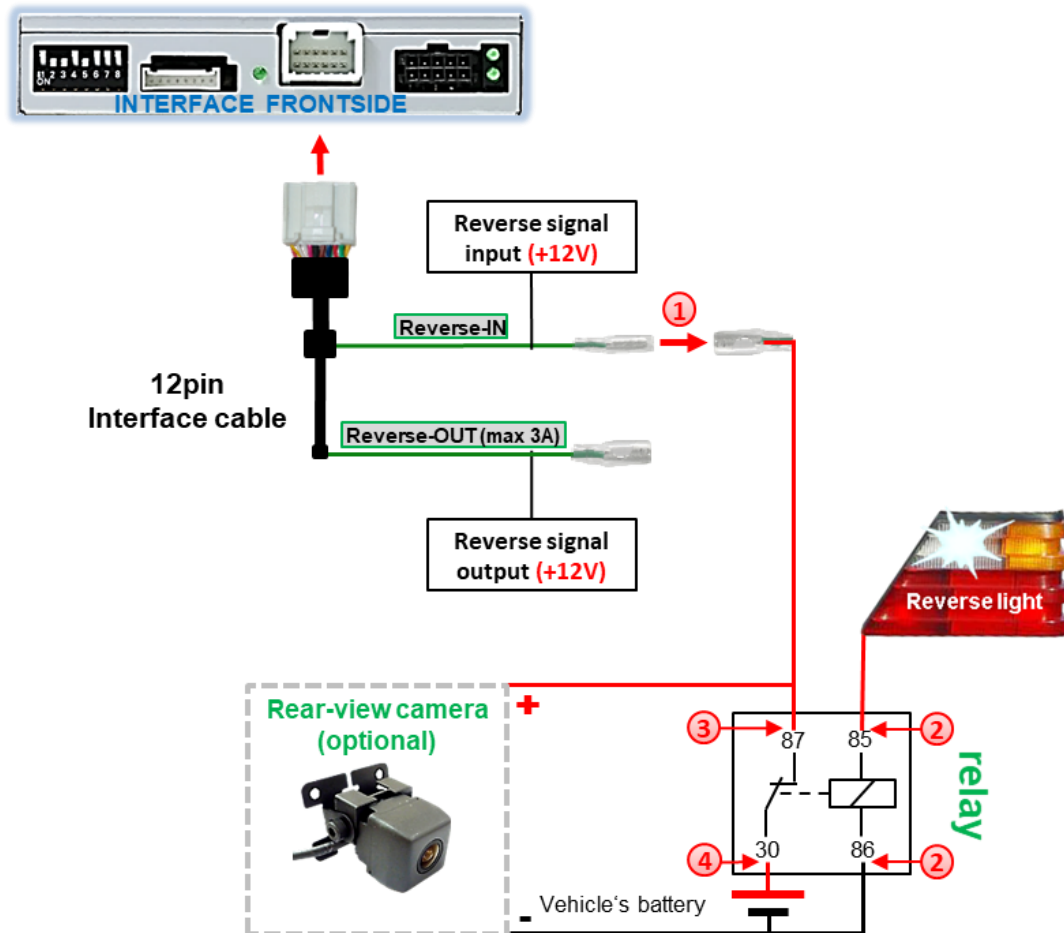

- ① Disconnect the green cable's pre-connected male- and female connectors of the 12pin cable and connect the green input cable "Reverse-IN" to the output connector (87) of the relay.

**Note:** Not least to avoid short circuits, the best solution should be, to crimp a male 4mm connector to the relay's output cable and connect it to the green cable's female 4mm connector. The output-cable "Reverse-OUT" remains disconnected as it's out of function.

- ② Connect the Reverse light's power-cable to coil (85) and the vehicle's ground to coil (86) of the relay.
- ③ Connect the output connector (87) of the relay to the rear-view camera's power-cable, like you did it to the green "Reverse-IN" cable before.
- ④ Connect permanent power / 12V to the relay's input connector (30).

## 3.4. Connection – video-interface and external keypad

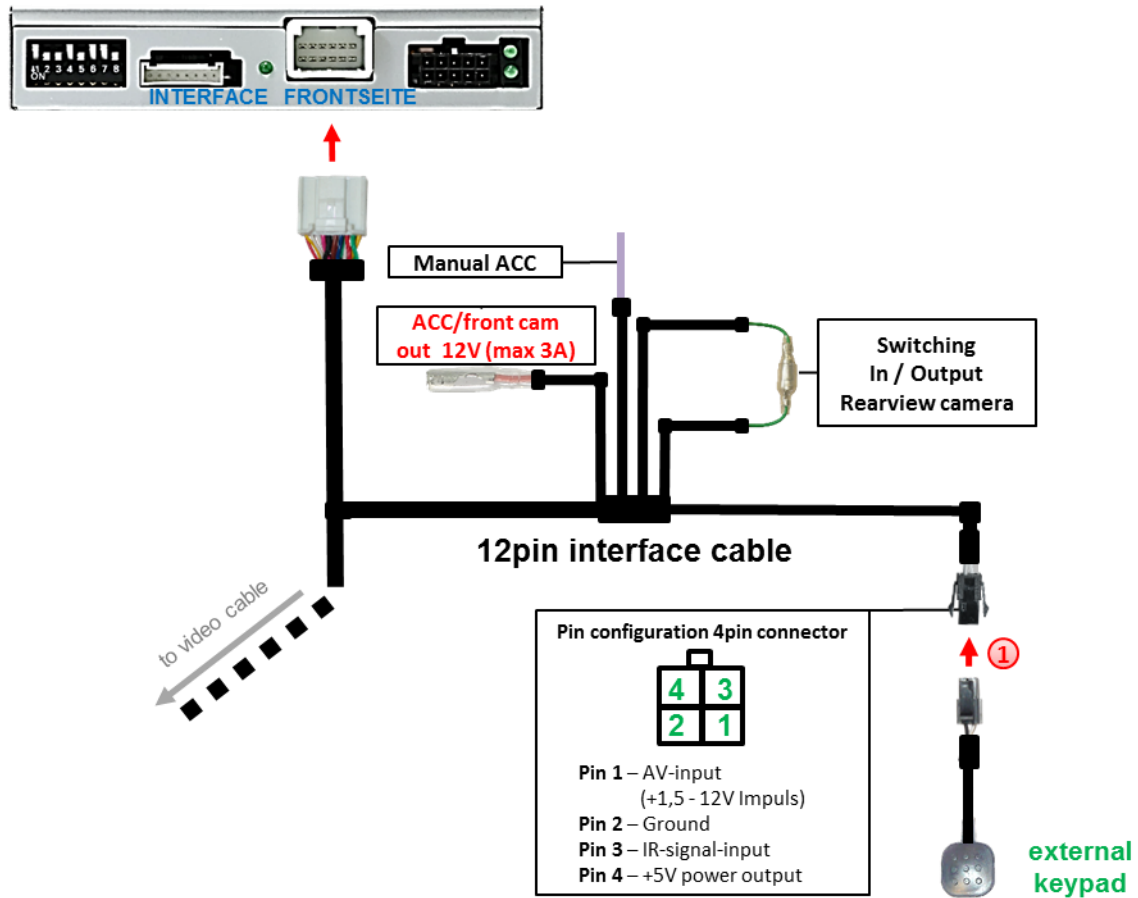

- 1 Connect the keypad's female 4pin connector to the 12pin interface cable's male 4pin connector.

**Note:** Even if the switching through several video sources by the keypad mightn't be required, the keypad's invisible connection and availability is strongly recommended.

## 3.5. Picture settings

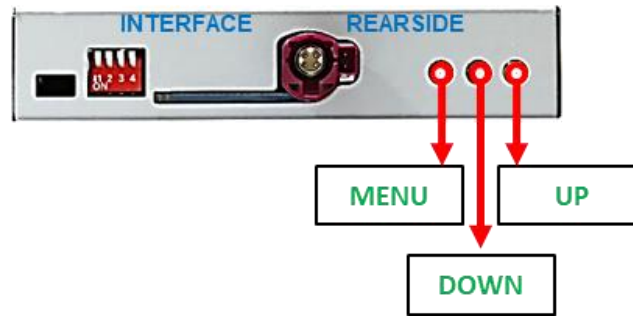

The picture settings are adjusted by the 3 buttons on the video-interface. Press the **MENU** button to open the OSD settings menu. To switch to the next menu item, pressing **UP** and **DOWN** will change the selected value. The buttons are embedded in the housing to avoid accidental changes during or after installation. The picture settings have to be done separately for AV1, AV2 and CAM while the corresponding input is selected and visible on the monitor.

**Note:** The OSD menu is only shown when a working video source is connected to the selected video-input of the interface.

The following settings are available

Contrast  
Brightness  
Saturation  
\*Position H (horizontal picture position)  
Position V (vertical picture position)

Contrast	50
Brightness	50
Saturation	62
Position-H	50
Position-V	20

\*If the dip switch setting of **dip8** has been set to **OFF** due to a displayed black image on an exception version of the head unit, the horizontal adjustment of the displayed image is not possible and a narrow stripe may remain on the left side in the display.

## 4. Interface operation

### 4.1. By Call-Off button

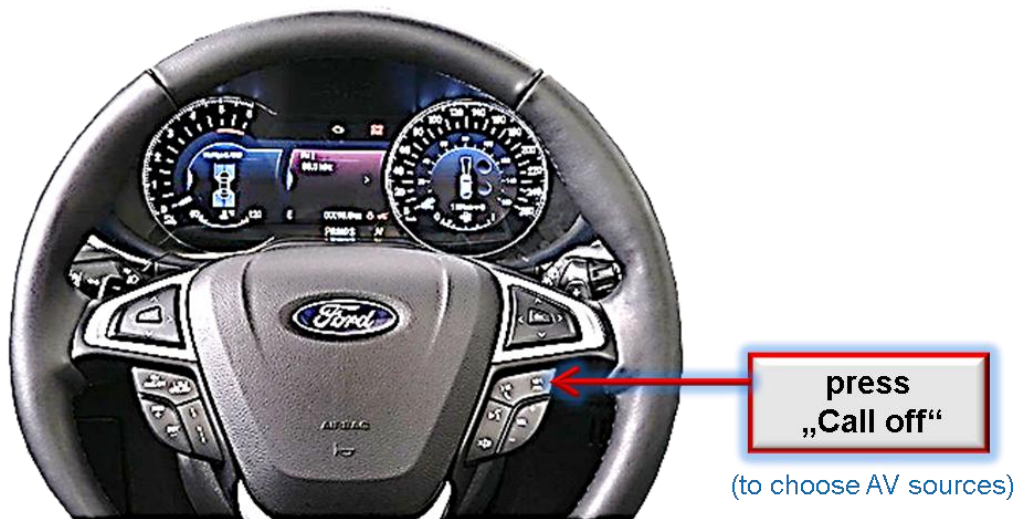

Switching the video sources can be done by a long press of the vehicle's **Call-Off button**

Each press (approx. 2-3sec) will switch to the next enabled input. If all inputs are enabled the order is:

*Factory video → video IN1 → video IN2 → factory video →...*

Disabled inputs will be skipped.

**Switchover by vehicle buttons isn't possible in all vehicles. In some vehicles the external keypad has to be used.**

### 4.2. By keypad

Alternatively or additionally to the factory infotainment buttons, the interface's external keypad can be used to switch the enabled inputs.

- Long press of keypad (2-3 seconds)

By long pressing the external keypad (2-3 seconds), the video interfaces switches the input from the factory video to the inserted video sources.

**Note:** The interface switches after releasing the switch (after long pressure).

- Short press of keypad (only if DIP 1 is set to ON)

By short pressing the external keypad, the video interfaces switches from the factory video to the front camera input and back to factory video.

## 5. Specifications

BATT/ACC range	9V - 16V
Stand-by power drain	about 5mA
Power consumption	about 300mA
Video input	0.7V - 1V
Video input formats	NTSC
RGB-video amplitude	0.7V with 75 Ohm impedance
Temperature range	-40°C to +85°C
Dimensions video-box	118 x 25 x 104 mm (W x H x D)

## 6. FAQ – Trouble shooting Interface functions

For any troubles which may occur, check the following table for a solution before requesting support from your vendor.

Symptom	Reason	Possible solution
No picture/black picture (factory picture).	Not all connectors have been reconnected to factory head-unit or monitor after installation.	Connect missing connectors.
	No power on CAN-bus box (all LED CAN-bus box are off).	Check power supply of CAN-bus box. Check CAN-bus connection of CAN-bus box.
	CAN-bus box connected to CAN-bus in wrong place.	Refer to the manual where to connected to the CAN-bus. If not mentioned, try another place to connect to the CAN-bus.
	No power on video-interface (all LED video-interface are off).	Check whether CAN-bus box delivers +12V ACC on red wire output of 8pin to 6pin cable. If not cut wire and supply ACC +12V directly to video-interface.
No picture/black picture/white picture (inserted picture) but factory picture is OK.	No picture from video source.	Check on other monitor whether video source is OK.
	No video-source connected to the selected interface input.	Check settings dips 1 to 3 of video interface which inputs are activated and switch to corresponding input(s).
	LVDS cables plugged in wrong place.	Double-check whether order of LVDS cables is exactly connected according to manual. Plugging into head-unit does not work when the manual says to plug into monitor and vice versa.
	Wrong monitor settings of video-interface.	Try different combinations of dips 7 and 8 of video-interface. Unplug 6pin power after each change.
Inserted picture totally wrong size or position.	Wrong monitor settings of video-interface.	Try different combinations of dips 7 and 8 of video-interface. Unplug 6pin power after each change.
Inserted picture double or 4 times on monitor.		
Inserted picture distorted, flickering or running vertically.	Video sources output set to AUTO or MULTI which causes a conflict with the interfaces auto detection.	Set video source output fixed to PAL or NTSC. It is best to set all video sources to the same standard.
	If error occurs only after source switching: Connected sources are not set to the same TV standard.	Set all video sources to the same standard.
	Some interfaces can only handle NTSC input.	Check manual whether there is a limitation to NTSC mentioned. If yes, set source fixed to NTSC output.
Inserted picture b/w.	Picture settings have not been adjusted.	Use the 3 buttons and the interface's OSD to adjust the picture settings for the corresponding video input.
Inserted picture qual. bad.		
Inserted picture size slightly wrong.		
Inserted picture position wrong.		
Camera input picture flickers.	Camera is being tested under fluorescent light which shines directly into the camera.	Test camera under natural light outside the garage.
Camera input picture is bluish.	Protection sticker not removed from camera lens.	Remove protection sticker from lens.

Symptom	Reason	Possible solution
Camera input picture black.	Camera power taken directly from reverse gear lamp.	Use relay or electronics to "clean" reverse gear lamp power. Alternatively, if CAN-bus box is compatible with the vehicle, camera power can be taken from green wire of 6pin to 8pin cable.
Camera input picture has distortion.		
Camera input picture settings cannot be adjusted.	Camera input picture settings can only be adjusted in AV2 mode.	Set dip 3 of video-interface to ON (if not input AV2 is not already activated) and connect the camera to AV2. Switch to AV2 and adjust settings. Reconnect camera to camera input and deactivate AV2 if not used for other source.
Graphics of a car in camera input picture.	Function PDC is ON in the interface OSD.	In compatible vehicles, the graphics will display the factory PDC distance. If not working or not wanted, set interface OSD menu item UI-CNTRL to ALLOFF.
Chinese signs in camera input picture	Function RET or ALL is ON (function for Asian market) in the interface OSD.	Set interface OSD menu item UI-CNTRL to ALLOFF or PDCON.
Not possible to switch video sources by OEM button.	CAN-bus interface does not support this function for vehicle.	Use external keypad or cut white wire of 6pin to 8pin cable and apply +12V impulses for AV-switching.
Not possible to switch video sources by external keypad.	Pressed too short.	For video source switching a longer press of about 2.5 seconds is required.
	SW-version of interface does not support external keypad.	Use OEM-button or cut white wire of 6pin to 8pin cable and apply +12V impulses for AV-switching.
Interface does not switch to camera input when reverse gear is engaged.	CAN-bus interface does not support this function for the vehicles.	Cut the green wire of the 6pin to 8pin cable and apply +12V constant from reverse gear-lamp signal. Use relay to "clean" R-gear lamp power.
Interface switches video-sources by itself.	CAN-bus interface compatibility to vehicle is limited.	Cut the grey wire of 6pin to 8pin and isolate both ends. If problem still occurs, additionally cut the white wire of 6pin to 8pin cable and isolate both ends.

## 7. Technical Support

Please note that direct technical support is only available for products purchased directly from NavLinkz GmbH. For products bought from other sources, contact your vendor for technical support.

**NavLinkz GmbH**  
**distribution/tech dealer-support**  
 Heidberghof 2  
 D-47495 Rheinberg

Tel +49 2843 17595 00  
 Email mail@navlinkz.de



Made in China