

SW-FRONTCAM

Video switch for retrofitting a front camera for RL1/RL2/RL3/VL1/VL2



- Switches automatically to front camera for 10 seconds after reverse gear has been engaged and then disengaged
- During this time, the video switch delivers a trigger output signal and enables the front camera to be fed into the rear camera input
- Compatible to RL1/RL2/RL3- and VL1/VL2-interfaces
- Power supply output for front and rear-view camera (500mA)
- Manual switching to front camera for 10 seconds possible (by +12V or ground trigger)
- On engaged reverse gear, the video switch always switches to rear-view camera

Note: Compatible with CVBS video-sources. Not compatible with AHD video-sources. The mixed use of video-sources with different video signal types, e.g., PAL and NTSC can, also depending on the video playback device, cause problems. It can only be tried and not predicted.

Wiring diagram in application with Aftermarket rear-view camera (chapter 1)

Reverse signal cables
See separate diagramm

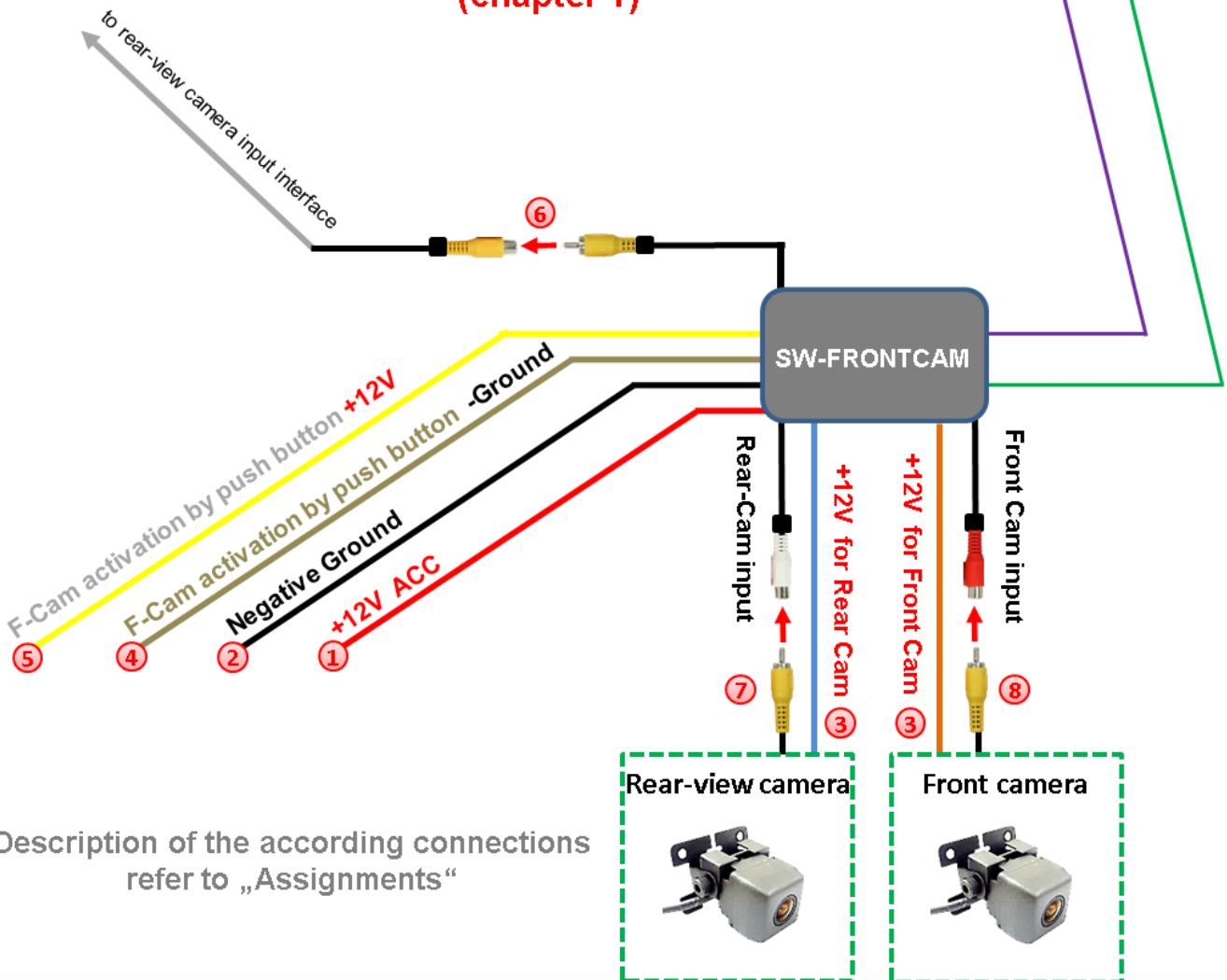

Wiring diagram in application with factory rear-view camera (chapter 2)

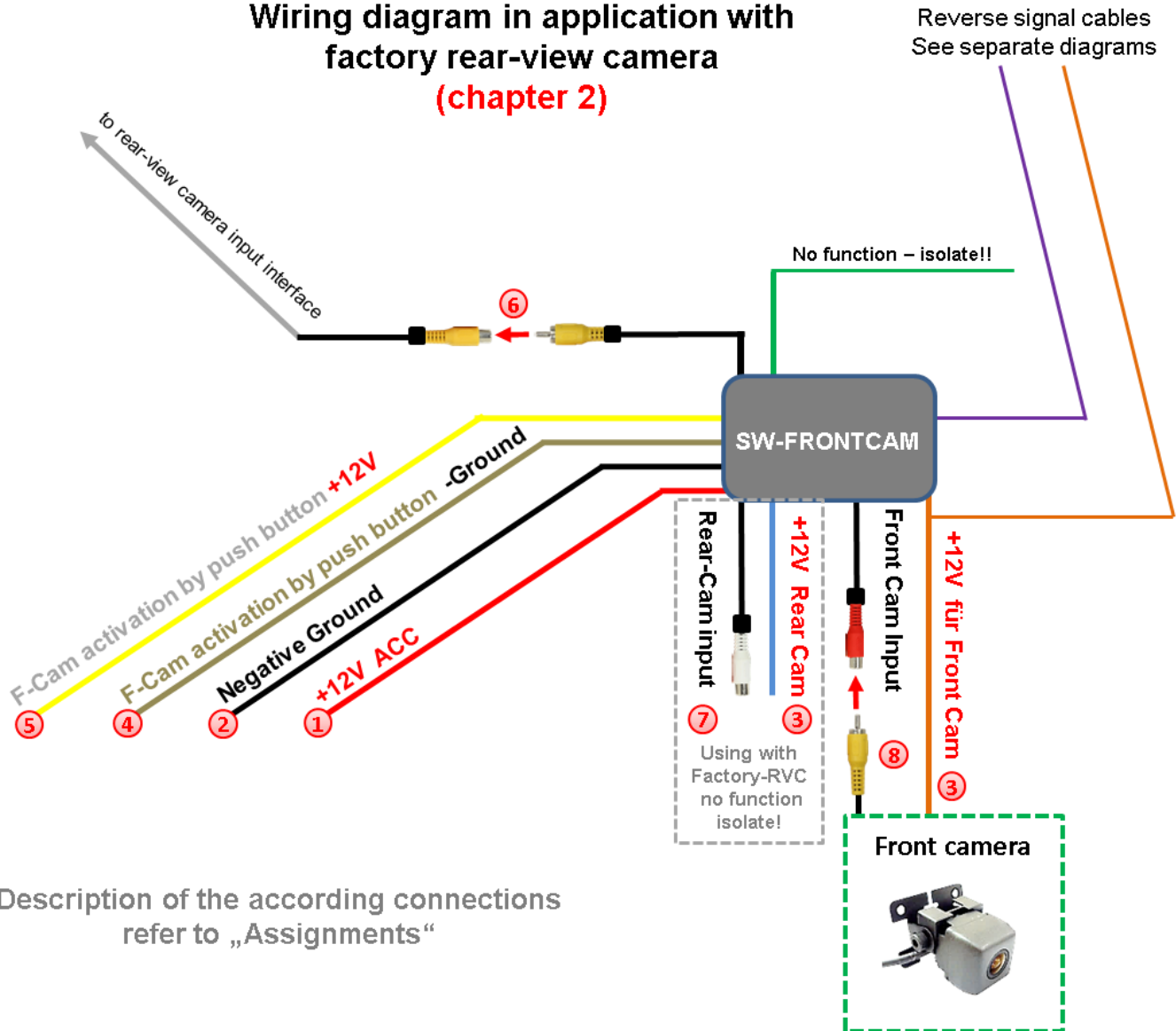

Description of the according connections refer to „Assignments“



Attention: With application of the factory rear-view camera, the orange coloured wire will take over the green wire's function. As the green wire keeps further powered during activity, isolating is strictly recommended to avoid short circuits!

The blue wire (+12V for rear-view camera) and the Cinch input connector remain unconnected, as the factory RVC keeps connected to the vehicle's head unit (please isolate!)

	Cable colour	Assignment
1	● Red	+12V ACC <i>Connect to ACC output of RL2/RL3/VL2/VL3 – or external ACC</i>
2	● Black	Ground
3	● Orange	+12V power output for front camera When using the system in application with the factory rear-view camera , the orange wire additionally serves as trigger output for the video interface. In this case the green trigger output wire remains unconnected and has to be isolated: RL3 – ● Reverse-In (green cable) RL2/VL2 - ● Cut green wire between CAN-box 8pin connector and video-box 6pin connector, connect to <u>video-box end</u> RL1/VL1 - ● Green wire
3	● Blue	+12V power output for rear-view camera
	● Purple	+ 12V power trigger input reverse gear <i>Connect to rear-vie camera trigger output</i> RL3/VL3 – ● Reverse- <u>Out</u> (green cable) RL2/VL2 - ● Cut green wire between CAN-box 8pin connector and video-box 6pin connector, connect to <u>CAN end</u> RL1/VL1 - ● Green wire
	● Green	+12V trigger output when front- and rear-view camera is on function (only for application with after-market rear-view camera!) <i>Connect to rear-vie camera trigger input</i> RL3/VL3 – ● Reverse- <u>In</u> (green cable) RL2/VL2 - ● Cut green wire between CAN-box 8pin connector and video-box 6pin connector, connect to <u>video-box end</u> RL1/VL1 - ● Green wire
Manual front camera activation <i>Connect only brown <u>or</u> yellow wire</i>		
4	● Brown	Ground impulse input trigger, connect to ground with optional push-button
5	● Yellow	+12V impulse input trigger, connect to 12V with optional push-button
RCA connectors		
6	● Yellow	Video output, connect to camera input of RL1/RL2/RL3/VL1/VL2
7	● White	Video input rear-view camera, connect to video output of rear-view camera
8	● Red	Video input front camera, connect to video output to front camera

Chapter 1

Trigger Connections – using After-Market rear-view cameras

Connection of the trigger input- and output wires to the video interface
(green coloured and purple coloured wires)

Connection to VL1 and RL1 interface

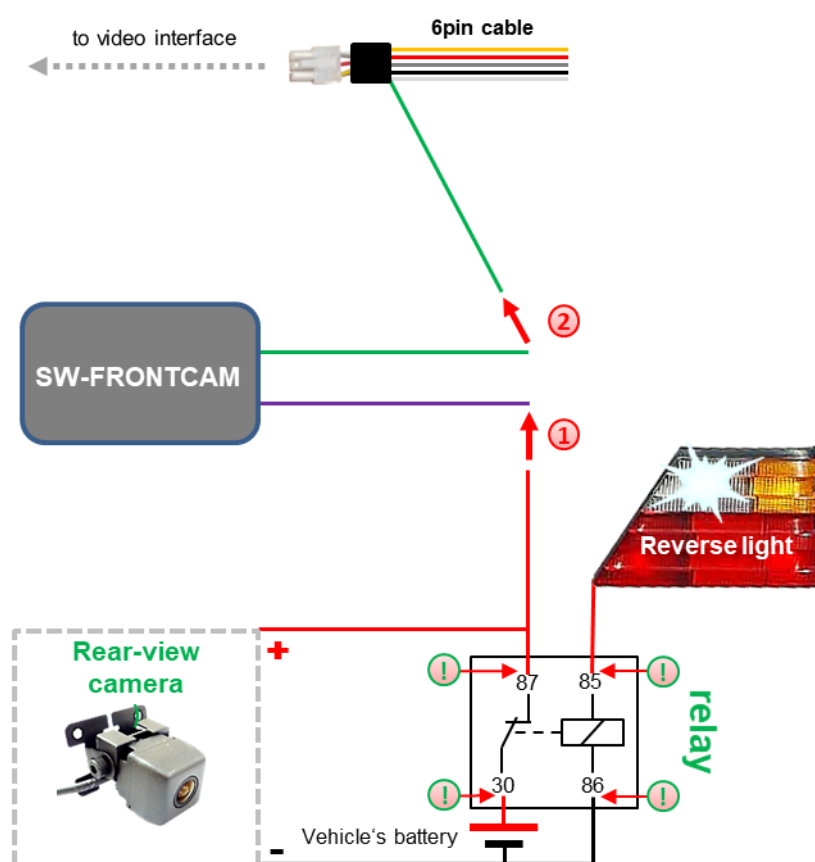

- 1 Connect the SW FRONTCAM's **purple coloured** trigger-input wire to the relay's terminal 87.
- 2 Connect the SW FRONTCAM's **green coloured** trigger-output wire to the 6pin cable's green coloured cable end.



Attention: For application with factory rear-view camera – see separate chapter!

Connection to VL2 and RL2 interface with CAN-BUS reverse signal

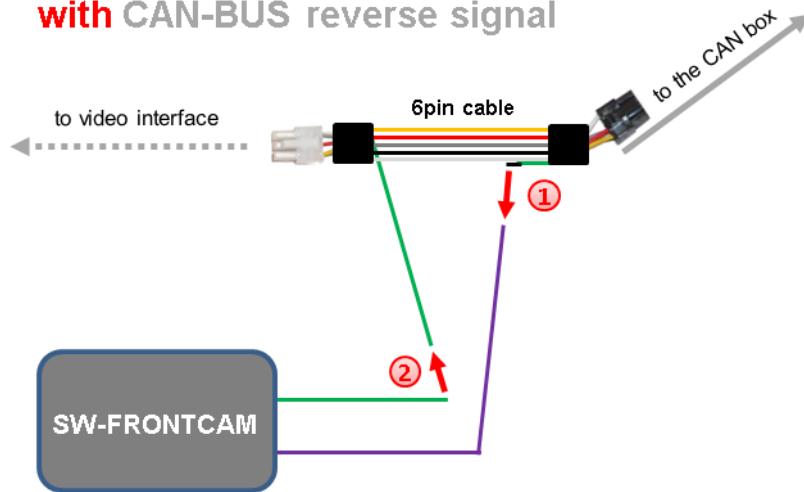

- 1 Cut the 6pin cable's green wire in the middle part and connect the SW FRONTCAM's **purple coloured** trigger-input wire to the 6pin cable's green coloured cable free end, close to the CAN-box.
- 2 Connect the SW FRONTCAM's **green coloured** Trigger-Output wire to the 6pin cable's free end, close to the interface box.



Attention: For application with factory rear-view camera – see separate chapter!

Connection to VL2 and RL2 interface **without** CAN-BUS reverse signal

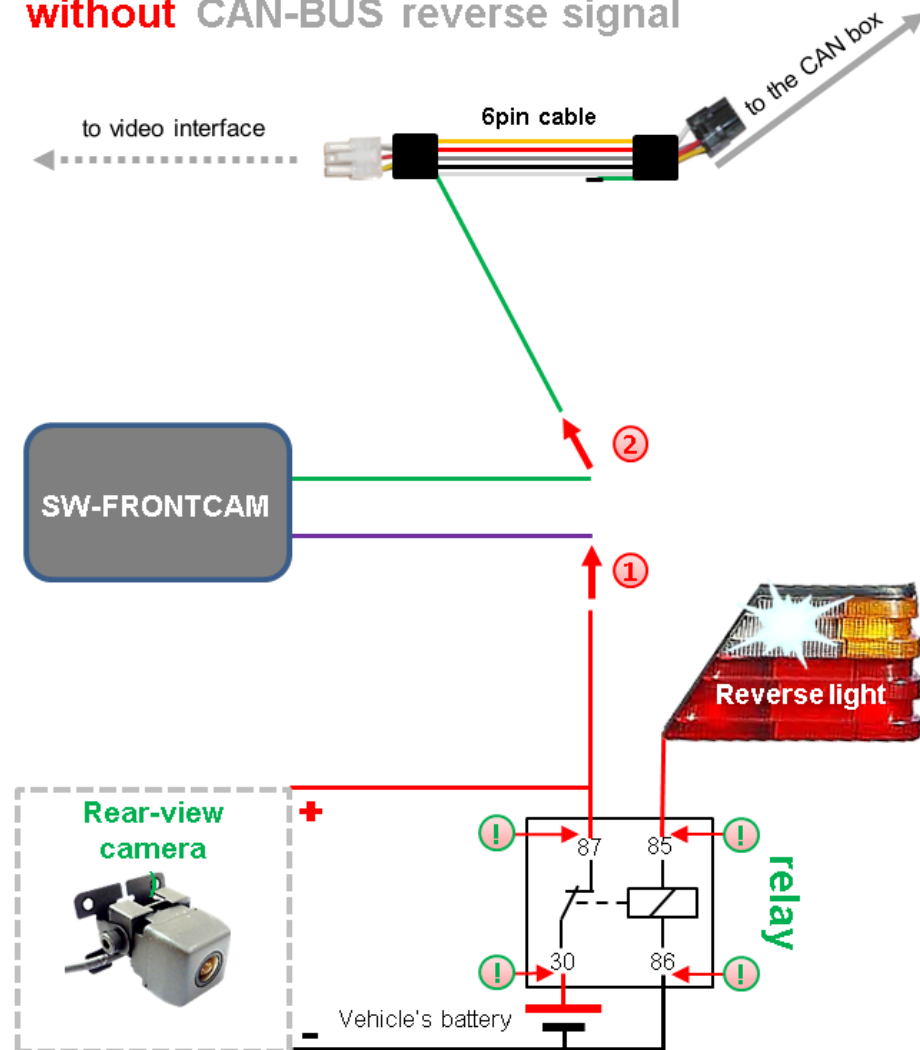

- 1 Connect the SW FRONTCAM's **purple coloured** trigger-input wire to the relay's terminal 87.
- 2 Connect the SW FRONTCAM's **green coloured** trigger-output wire to the 6pin cable's green coloured cable end „**Reverse-IN**“ close to the interface box.



Attention: For application with factory rear-view camera – see separate chapter!

Connection to RL3 interface with CAN-BUS reverse signal

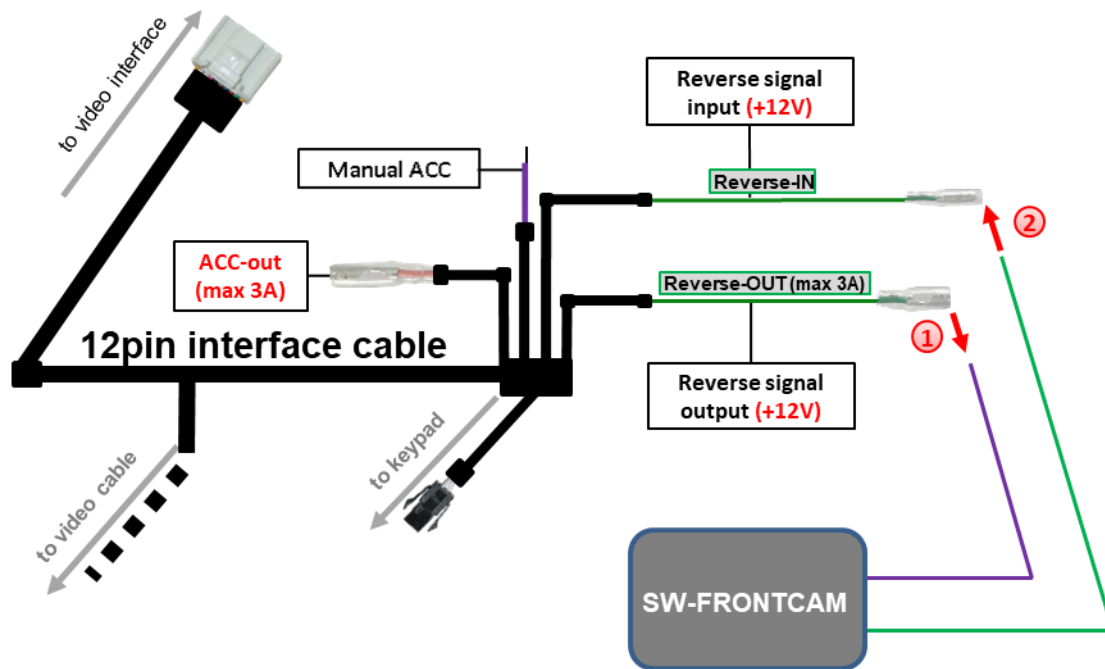

- 1 Connect the SW FRONTCAM's **purple coloured** trigger-input wire to the 12pin interface cable's green wire „**Reverse-OUT (max 3A)**“.
- 2 Connect the SW FRONTCAM's **green coloured** trigger-output wire to the 12pin interface cable's green wire „**Reverse-IN**“.



Attention: For application with factory rear-view camera – see separate chapter!

Connection to RL3 interface without CAN-BUS reverse signal

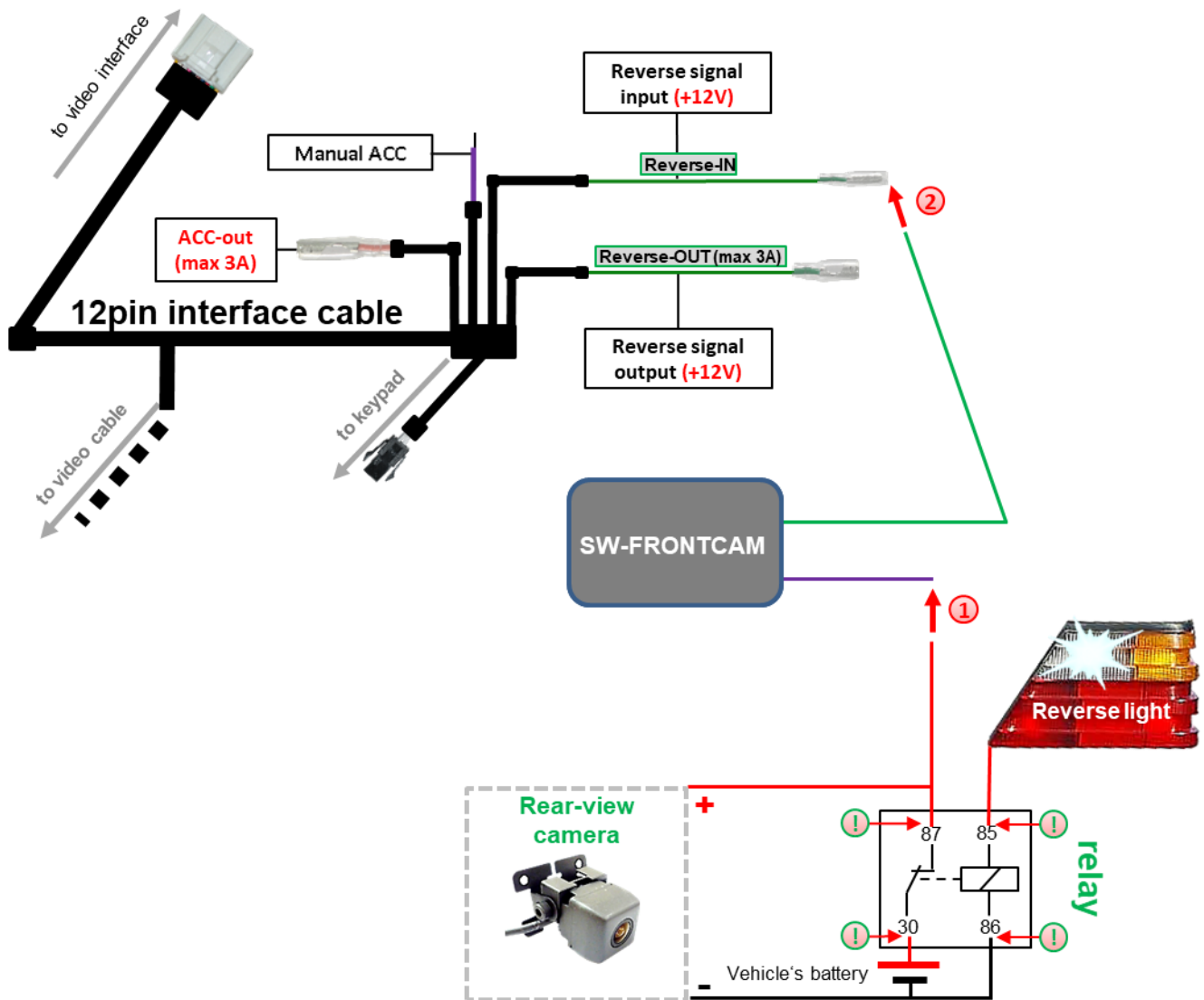

- ① Connect the SW FRONTCAM's **purple coloured** trigger-input wire to the relay's terminal 87.
- ② Connect the SW FRONTCAM's **green coloured** trigger-output wire to the 12pin interface cable's green wire „Reverse-IN“.



Attention: For application with factory rear-view camera – refer to chapter 2!

Chapter 2

Trigger Connections – using factory rear-view cameras

Connection of the trigger input- and output wires to the video interface
(orange coloured and purple coloured wires)

Connection to VL1 and RL1 interface

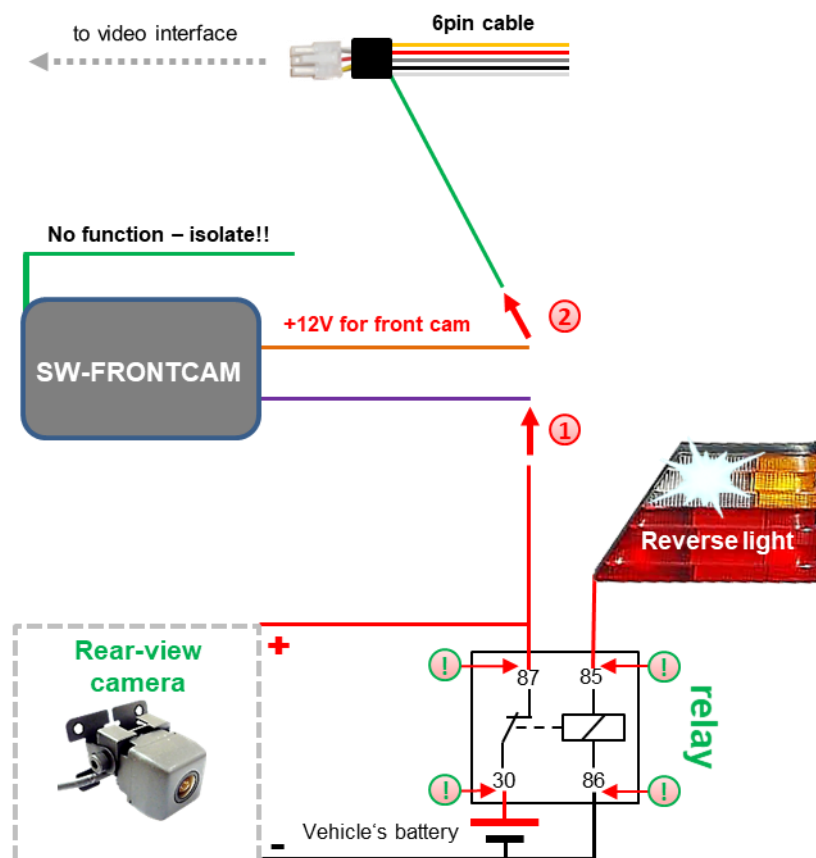

- ① Connect the SW FRONTCAM's **purple coloured** trigger-input wire to the relay's terminal 87.
- ② Connect the SW FRONTCAM's **orange coloured** power supply wire for the front camera to the 6pin cable's free end.
(orange wire serves additionally as trigger output wire of the SW-FRONTCAM)



Attention: The green wire's isolating is strictly recommended as it's powered during activity!

Connection to VL2 and RL2 interface with CAN-BUS reverse signal

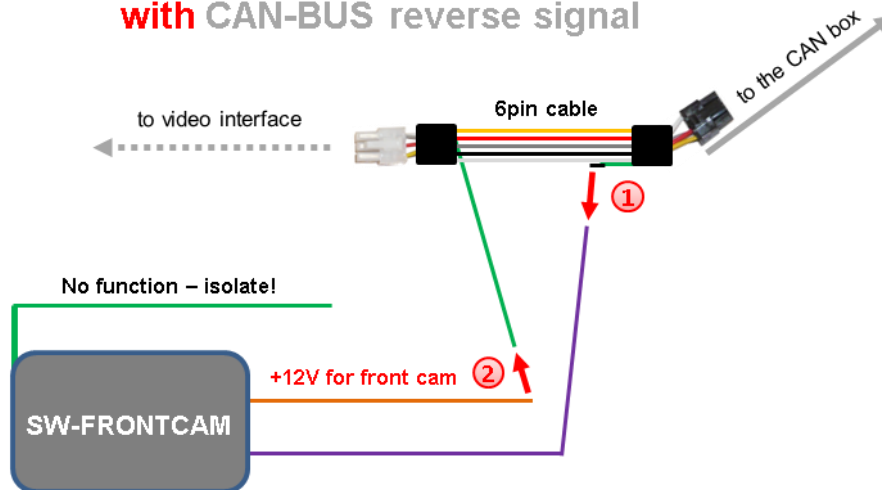

- 1 Cut the 6pin cable's green wire in the middle part and connect the SW FRONTCAM's **purple coloured** trigger-input wire to the 6pin cable's green coloured cable free end, close to the CAN-box.
- 2 Connect the SW FRONTCAM's **orange coloured** power supply wire for the front camera to the 6pin cable's free end, close to the interface box. (orange wire serves additionally as trigger output wire of the SW-FRONTCAM)



Attention: The green wire's isolating is strictly recommended as it's powered during activity!

Connection to VL2 and RL2 interface **without** CAN-BUS reverse signal

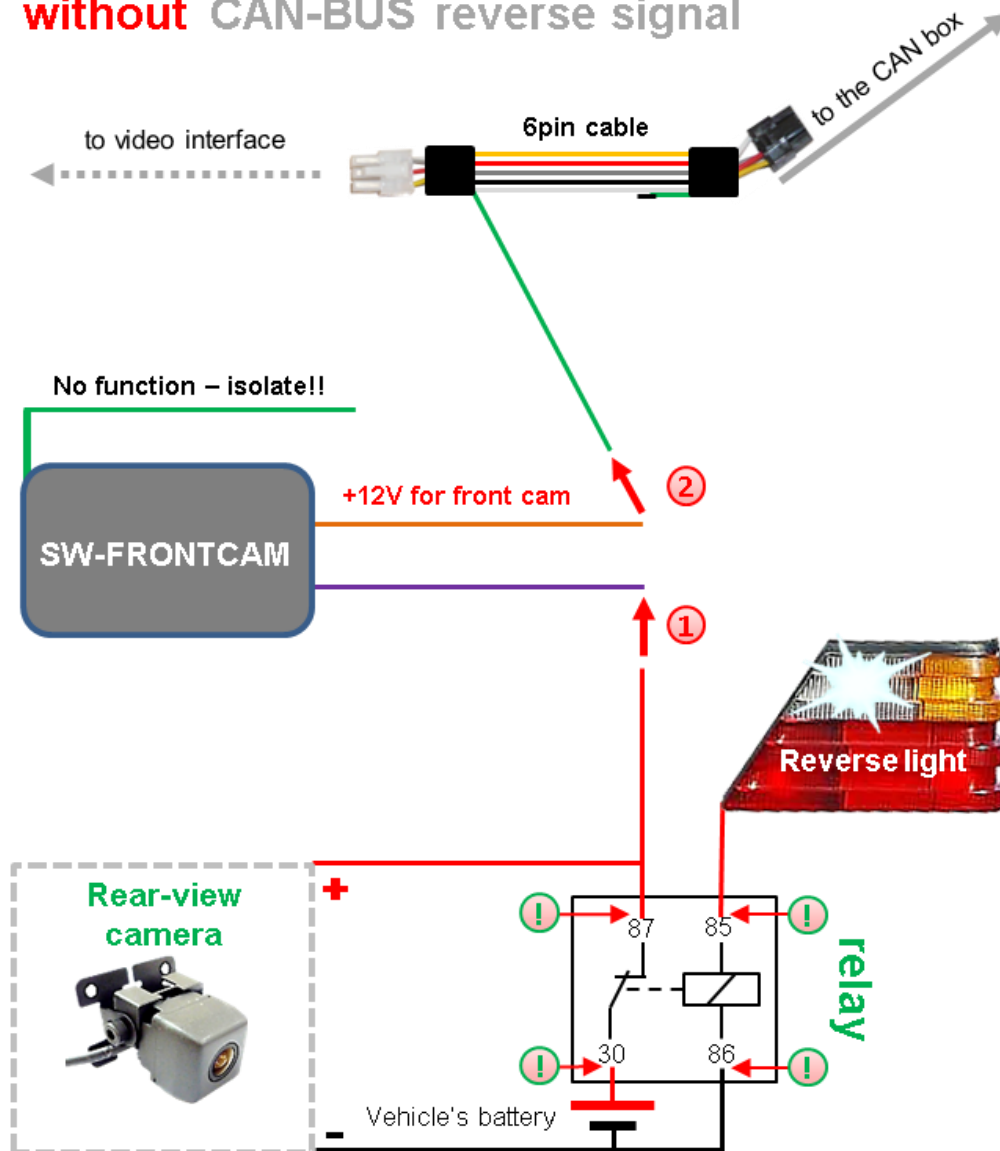

- 1 Connect the SW FRONTCAM's **purple coloured** trigger-input wire to the relay's terminal 87.
- 2 Connect the SW FRONTCAM's **orange coloured** power supply wire for the front camera to the 6pin cable's free end, close to the interface box.
(orange wire serves additionally as trigger output wire of the SW-FRONTCAM)



Attention: The green wire's isolating is strictly recommended as it's powered during activity!

Connection to RL3 interface with CAN-BUS reverse signal

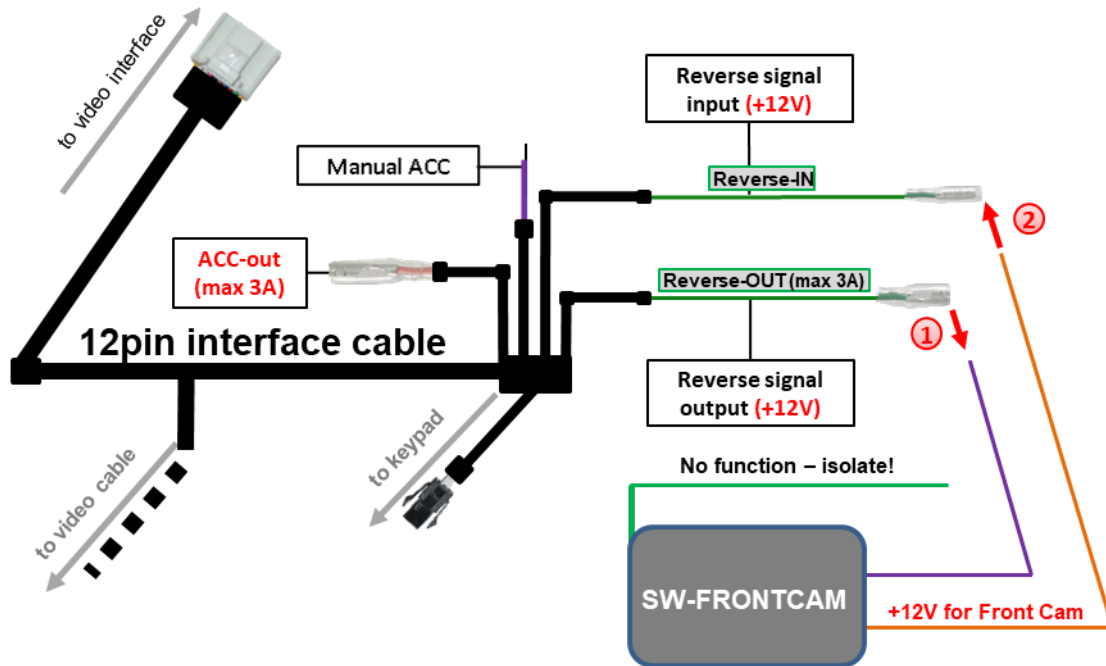

- 1 Connect the SW FRONTCAM's to the 12pin interface cable's green wire „Reverse-OUT (max 3A)“
- 2 Connect the SW FRONTCAM's orange coloured power supply wire for the front camera to the 12pin interface cable's green wire „Reverse-IN“ (orange wire serves additionally as trigger output wire of the SW-FRONTCAM)



Attention: The green wire's isolating is strictly recommended as it's powered during activity!

Connection to RL3 interface without CAN-BUS reverse signal

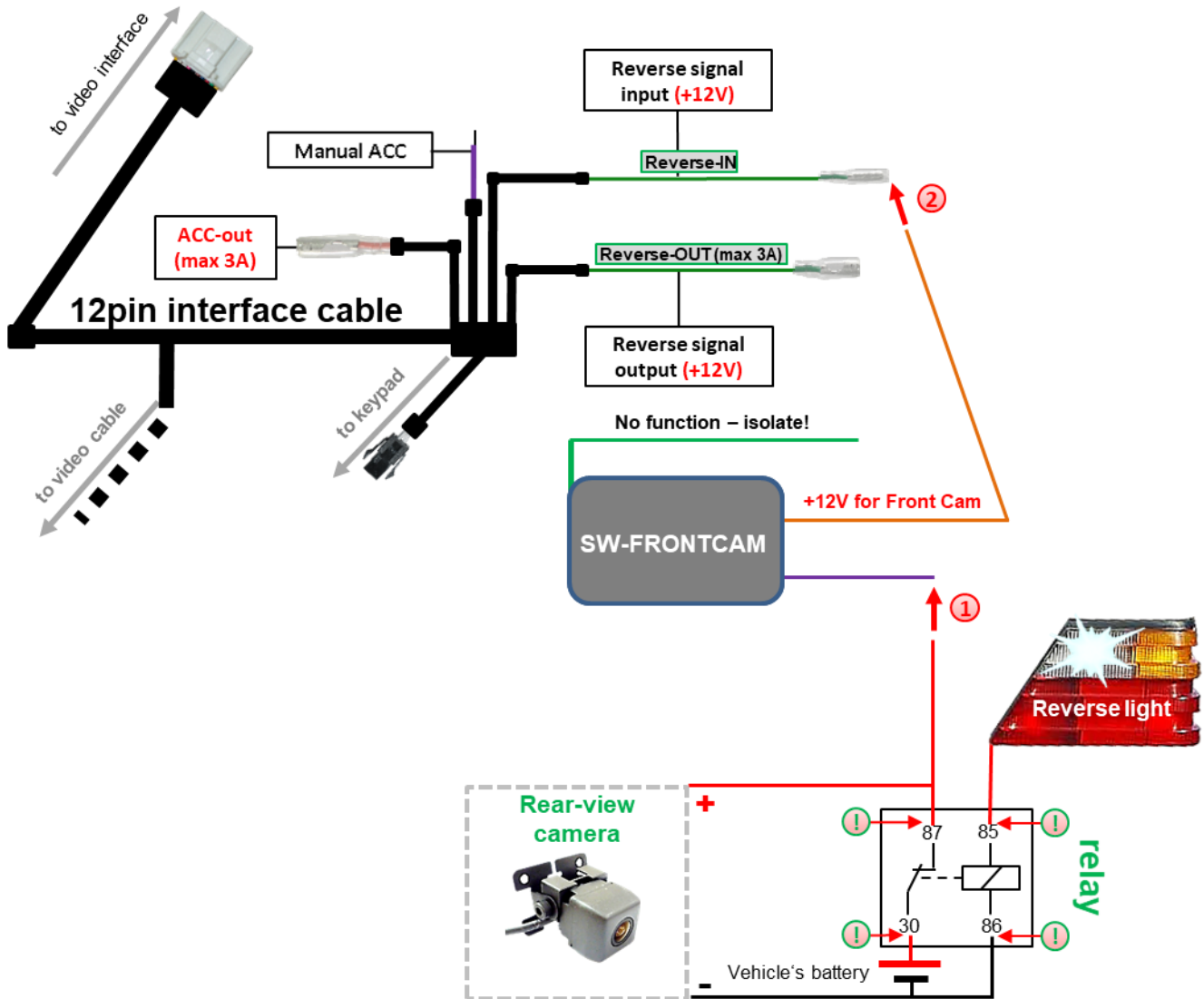

- ① Connect the SW FRONTCAM's **purple coloured** trigger-input wire to the relay's terminal 87.
- ② Connect the SW FRONTCAM's **orange coloured** power supply wire for the front camera to the 12pin interface cable's green wire „Reverse-IN“. (orange wire serves additionally as trigger output wire of the SW-FRONTCAM).



Attention: The green wire's isolating is strictly recommended as it's powered during activity!