

## Video-inserter

# VL1-MBN2

Compatible with Mercedes Benz vehicles  
with Comand APS NTG1 and NTG2 infotainment



### Video-inserter with 2 video inputs + rear-view camera input

#### Product features

- Video-inserter for factory-infotainment systems
- 2 CVBS video-inputs for after-market devices (e.g. USB-player, DVB-T2 tuner)
- Built-in audio-switch (no audio-insertion)
- Rear-view camera CVBS video-input
- Automatic switching to rear-view camera input on engagement of the reverse gear
- Video-in-motion (ONLY for connected video-sources)
- Video-inputs NTSC compatible (in exceptional cases PAL - see restrictions)

## Contents

### 1. Prior to installation

- 1.1. Delivery contents
- 1.2. Checking the compatibility of vehicle and accessories
- 1.3. Boxes and connectors
  - 1.3.1. Video-Interface
  - 1.3.2. CAN-bus box
  - 1.3.3. Dip-switch settings – interface
    - 1.3.3.1. Enabling the interface's video inputs (dip 2-3)
    - 1.3.3.2. Rear-view camera setting (dip 5)
    - 1.3.3.3. Monitor specific settings (dip 6, 7+8)

### 2. Installation

- 2.1. Place of installation
  - 2.1.1. Place of Installation – video interface and daughter PCB
- 2.2. Connection schema
- 2.3. Connection – 6pin interface cable
- 2.4. Connection – daughter PCB and ribbon cables
  - 2.4.1. Ribbon cable 1
  - 2.4.2. Ribbon cable 2
  - 2.4.3. Warning notes, concerning the installation of ribbon cables
- 2.5. Connection – picture signal cable
- 2.6. Connection – video sources
- 2.7. Audio-switch and audio-insertion
- 2.8. After-market rear-view camera
- 2.9. Connection – video interface and external keypad
- 2.10. Picture settings and guide lines

### 3. Video interface operation

- 3.1. By external keypad
- 3.2. By white wire of the 6pin cable

### 4. Specifications

### 5. FAQ – Trouble Shooting-Interface functions

### 6. Technical support

## Legal Information

By law, watching moving pictures while driving is prohibited, the driver must not be distracted. We do not accept any liability for material damage or personal injury resulting, directly or indirectly, from installation or operation of this product. Apart from using this product in an unmoved vehicle, it should only be used to display fixed menus or rear-view-camera video when the vehicle is moving (for example the MP3 menu for DVD upgrades).

Changes/updates of the vehicle's software can cause malfunctions of the interface. Up to one year after purchase we offer free software-updates for our interfaces. To receive a free update, the interface has to be sent in at own cost. Wages for de-and reinstallation and other expenditures involved with the software-updates will not be refunded.

No liability for vehicle wire colours and pin definition!

Changes by the vehicle manufacturer are possible. The given information has to be verified by the installer.

## 1. Prior to installation

Read the manual prior to installation. Technical knowledge is necessary for installation. The place of installation must be free of moisture and away from heat sources.

### 1.1. Delivery contents

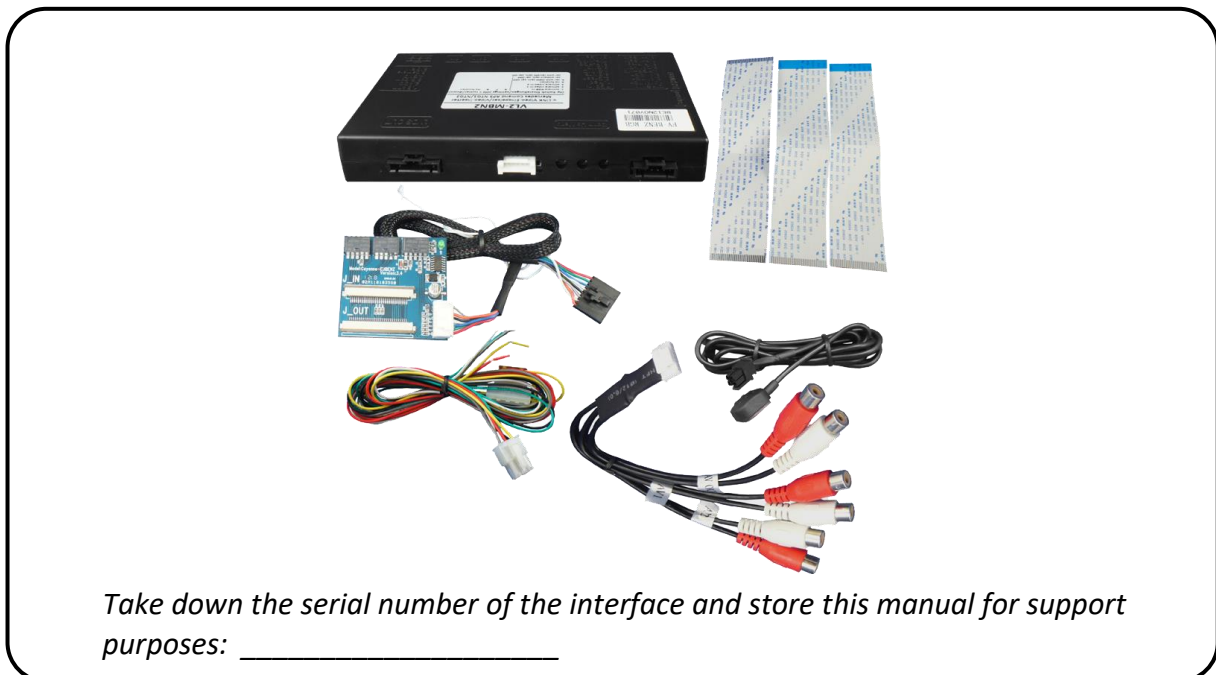

## 1.2. Checking the compatibility of vehicle and accessories

### Requirements

Brand	Compatible vehicles	Compatible systems
Mercedes	CLS-Coupe ((W219) from 10/2004 til 03/2008, E-class (W211) til 05/2008, SLK-class (R171) from 03/2004 til 03/2008	Comand APS DVD (NTG1) Siemens/VDO
	A-class (W169) from 10/2004 til 06/2008, B-class (W245) from 09/2004 til 06/2008, C-class (W203) from 04/2004 til 02/2007, CLC (CL203) from 06/2008 til 09/2008, CLK (C209 W209) from 06/2004, G-class (G463) from 04/2007 til 08/2008, GL-class (X164) til 06/2008, ML-class (W164) til 06/2008, R-class (W251) til 06/2008, Sprinter (W906) from about 04/2006, Viano (W639)	Comand APS NTG2

### Limitations

<i>Video only</i>	Interface inserts ONLY video signals into the infotainment. For inserting Audio signals either the possibly existing factory audio-AUX-input, an FM-modulator or AUX-in interface can be used. The factory audio AUX can be coded by the dealership.
<i>Factory rear-view camera</i>	Automatically switching-back from inserted video to factory rear-view camera is only possible while the reverse gear is engaged.
Video-sources	Video-inputs of interface are compatible with NTSC sources only. But if a factory TV-tuner is installed, it is possible that only PAL sources can be connected.
Video-quality	<b>Video quality of inserted picture is often limited.</b> It is also <b>possible that inserted picture has a color touch</b> (e.g., greenish). This cannot be changed, nor predicted prior to installation. We therefore recommend the use only for camera systems.

## 1.3. Boxes and connectors

### 1.3.1. Video Interface

The video-interface converts the video signals of connected after-market sources in a factory monitor compatible picture signal which is inserted in the factory monitor, by using separate trigger options.

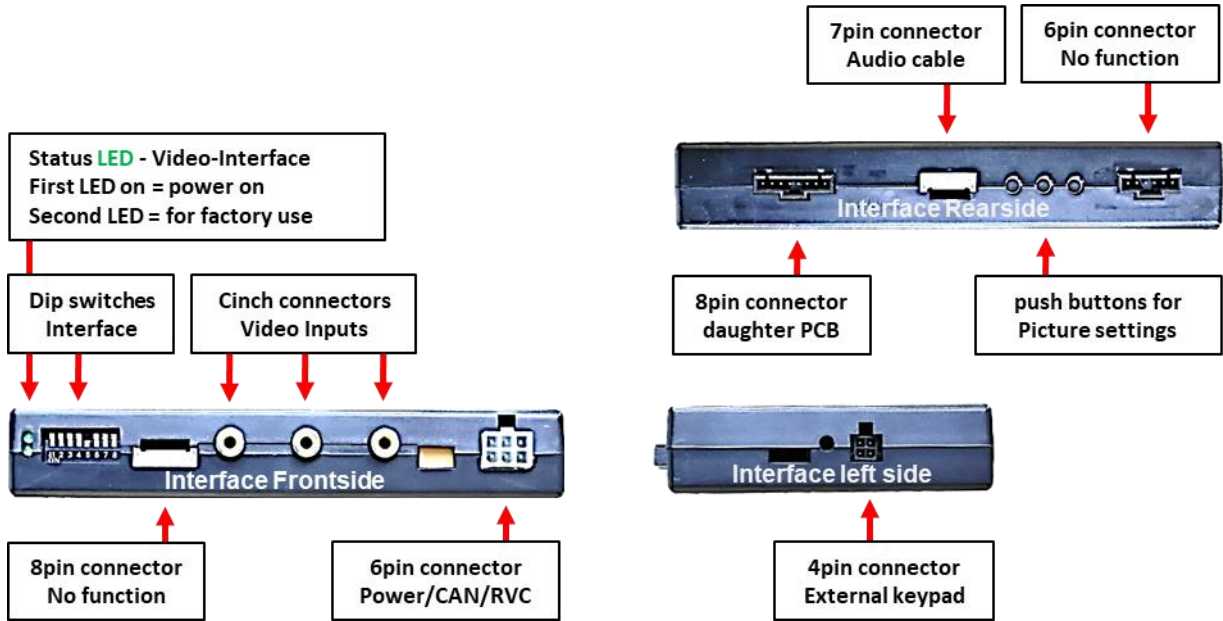

### 1.3.2. Daughter PCB



## 1.3.3. Dip-switch settings – interface

Some settings have to be selected by the dip-switches on the video interface. Dip position down is ON and position up is OFF.



Dip	Function	ON (down)	OFF (up)
1	No function		set to OFF
2	CVBS AV1-input	enabled	disabled
3	CVBS AV2-input	enabled	disabled
4	No function		set to OFF
5	Rear-view cam type	after-market	factory or none
6	Monitor specific adjustment		set to OFF
7			
8			

**After each Dip-switch-change a power-reset of the Can-box has to be performed!**

See the following chapters for detailed information.

### 1.3.3.1. Enabling the interface's video inputs (dip 2-3)

Only the enabled video inputs can be accessed by switching through the interface's video sources. It is recommended to enable only the required inputs, because the disabled inputs will be skipped while switching through the video interfaces inputs.

### 1.3.3.2. Rear-view camera setting (dip 5)

If set to **OFF**, the interface switches to factory LVDS picture while the reverse gear is engaged to display factory rear-view camera or factory optical park system picture.

If set to **ON**, the interface switches to its rear-view camera input while the reverse gear is engaged.

### 1.3.3.3. Monitor specific settings (dip6 to dip8)

Set all 3 dip switches to **OFF**.

Dips 1 and 4 are out of function and have to be set to **OFF**.

## 2. Installation

To install the interface, first switch off the ignition and disconnect the vehicle's battery. Please read the owner's manual of the car, regarding the battery's disconnection! If required, enable the car's Sleep-mode (hibernation mode)

In case the sleep-mode does not succeed, the disconnection of the battery can be done with a resistor lead.

If the necessary stabilized power supply for the interface is not taken directly from the battery, the chosen connection has to be checked for being constantly stable.

The interface needs a permanent 12V source!

### 2.1.1. Place of installation – video interface and daughter PCB

The Interface Box shell will be installed behind the head unit and the daughter PCB will be installed between the monitor panel and the mainboard of the Head Unit. For this the Head Unit has to be removed and dismantled.

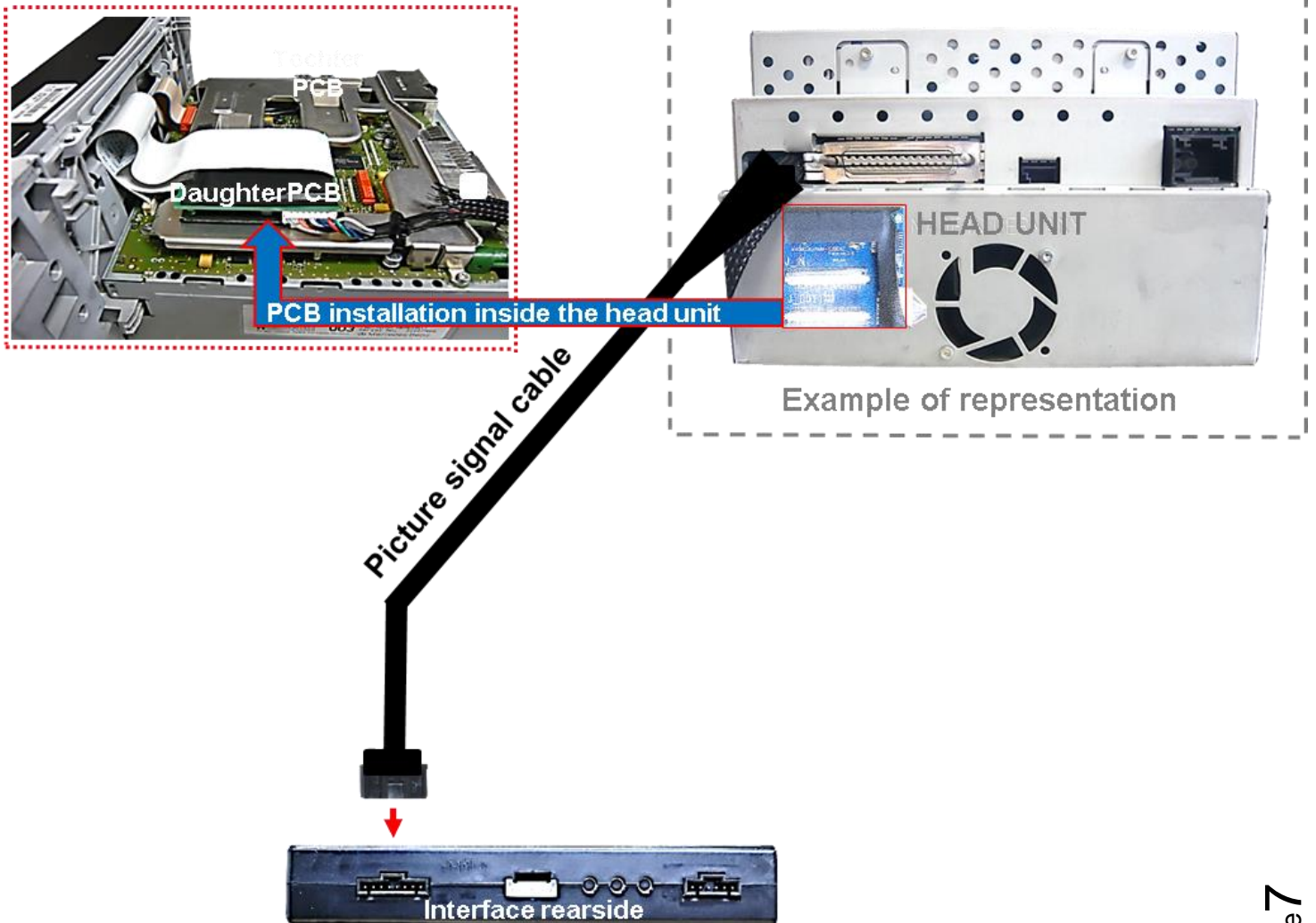

## 2.2. Connection schema

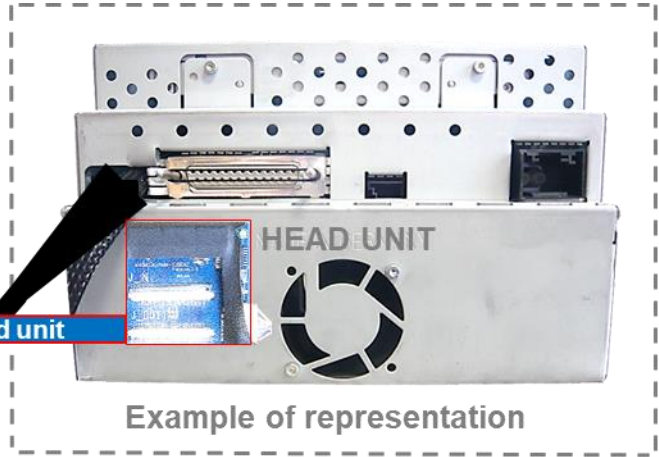

Picture signal cable

+12V battery

+12V ACC

no function

negative ground

AV switch

RVC - signal



6pin cable



External keypad



Audio-insertion (optional)

Aux Input

Audio OUT

Audio 1 IN

Audio 2 IN

Video IN 1

Video IN 2

Camera IN



Video-source 1 (optional)

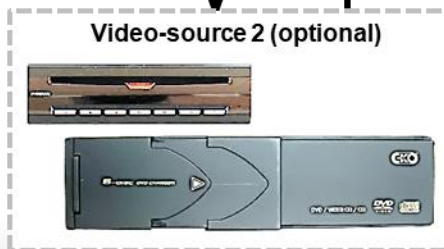

Video-source 2 (optional)



Rearview camera (optional)

## 2.3. Connection – 6pin interface cable

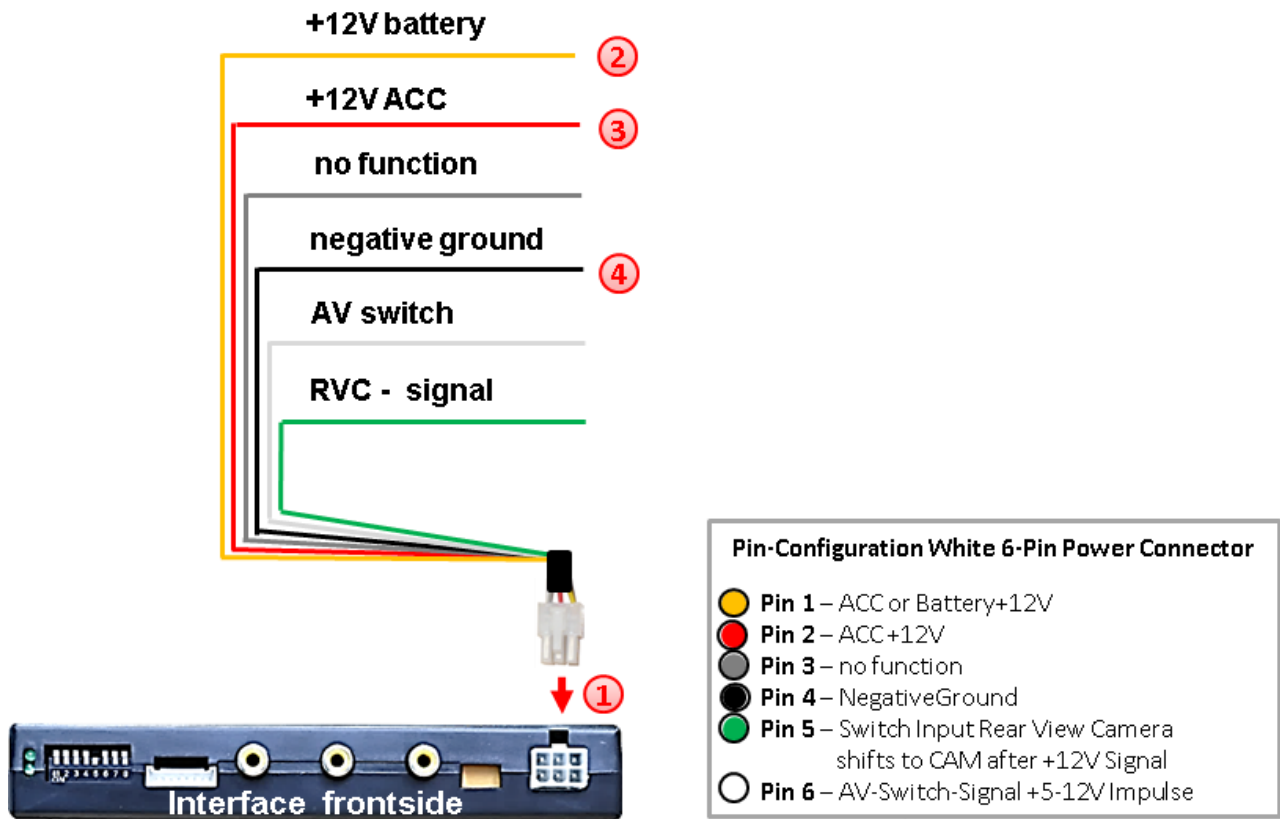

- 1 Connect the female white 6-pin connector of the 6-pin interface cable to the male 6-pin connector of the video interface.
- 2 Connect the yellow wire of the 6-pin interface cable to +12V battery or ACC.
- 3 Connect the red wire of the 6-pin interface cable to +12V ACC.
- 4 Connect the black wire of the 6-pin interface cable to vehicle ground.

**Note:** The connection of the green wire (Reverse signal) will be described in chapter “After-market rear-view camera”. The white wire, can be used to switch the enabled video sources same as the keypad (see chapter “video interface-operation”). The grey wire stays unconnected.

## 2.4. Connection – daughter PCB and ribbon cables

Open the Head-Unit housing, expose the ribbon cable bases of the factory ribbon cable, clip them out and remove the factory ribbon cable.

The factory ribbon cable between monitor- and head-Unit PCB must be replaced by 2 of the 3 supplied ribbon cables (input and output cable).



**Attention: Failure to replace the original factory ribbon cable in most cases leads to an unstable or rolling image display!**

2 pin-twisted and 1 pin-straight 30-pin flex cables are included. NTG1 and NTG2 systems have a different orientation of the ribbon cable bases on the monitor panel and on the mainboard. Depending on the system, either 2 pin-twisted or 1 pin-twisted and 1 pin-straight ribbon cable have to be installed.

**NTG1:** Use 1 x pin-twisted and 1 x pin-straight ribbon cables.

**NTG2:** Use 2 x pin twisted ribbon cables.

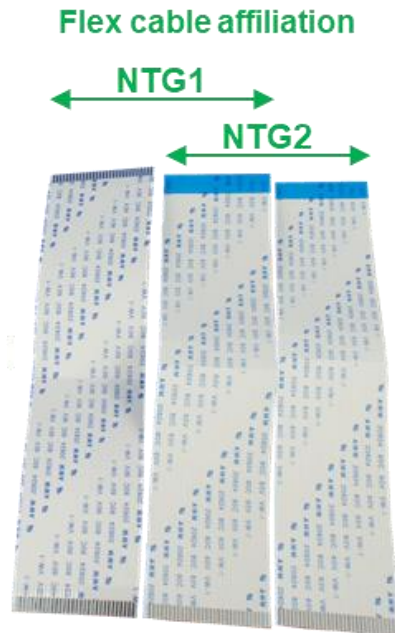

## 2.4.1. Ribbon cable 1

Example: NTG2  
(2 x pin-twisted ribbon cable)

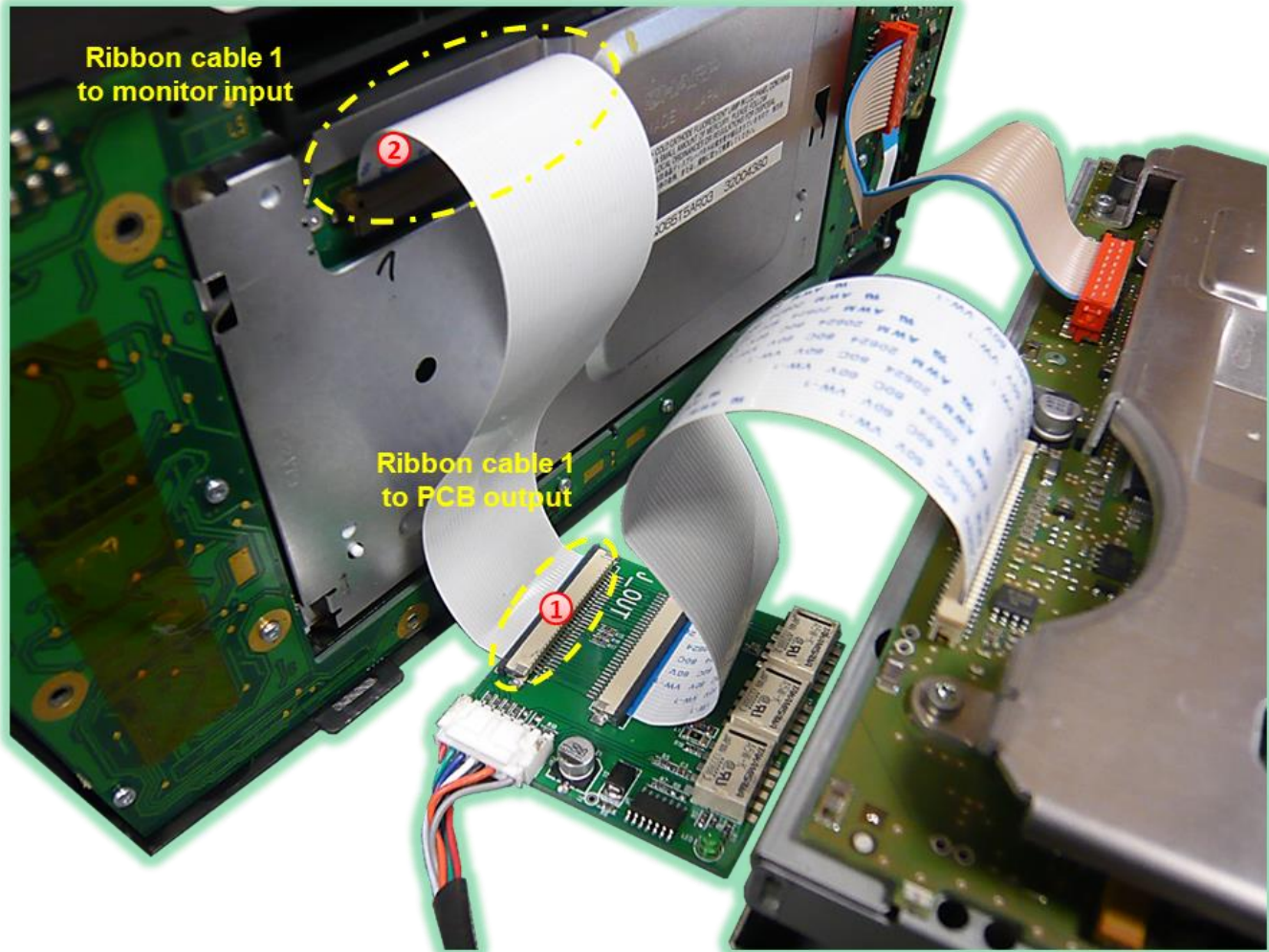

- 1 Connect the one of the two system-related ribbon cables to the enclosed daughter PCB's ribbon cable base "J-OUT" and clip it in.
- 2 Connect and clip the opposite side of this ribbon cable to the previously become free ribbon cable base of the factory monitor PCB.



Electrical the contacts have to be transmitted similar, in other words the left contact of the monitor panel have to be connected with the left contact of the mainboard. Please take note of the contact surfaces of the flex cables during installation.

## 2.4.2. Ribbon cable 2

Example: NTG2  
(2 x pin-twisted ribbon cable)

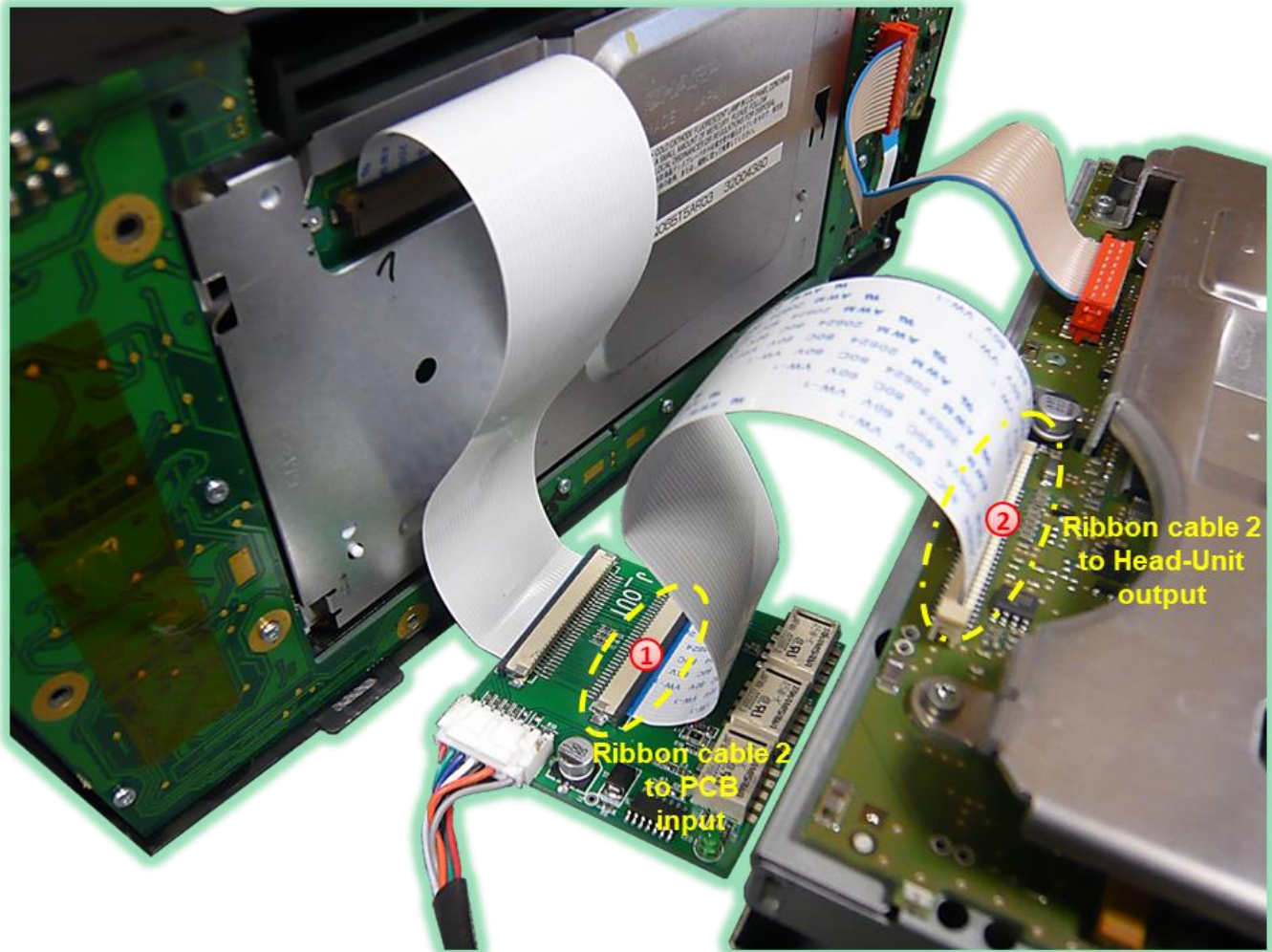

- 1 Connect the second one of the two system-related ribbon cables to the enclosed daughter PCB's ribbon cable base "J-IN" and clip it in.
- 2 Connect and clip in the opposite side of this ribbon cable to the previously become free ribbon cable base of the factory head-unit PCB (heed the following warning notes!).

### 2.4.3. Warning notes, concerning the installation of ribbon cables:

1) The contacting ends of ribbon cables always have to be installed in a straight and precise 180° position to the connector. Each deviation from a perfect contact position will cause faulty contact and even danger of short circuit

2) The ribbon cable's contacting side always has to correspond to the contacting side of the connector, concerning the mounting position.

3) Avoid cable contusion or cable injury caused by sharp-edged metal.

## 2.5. Connection - picture signal cable

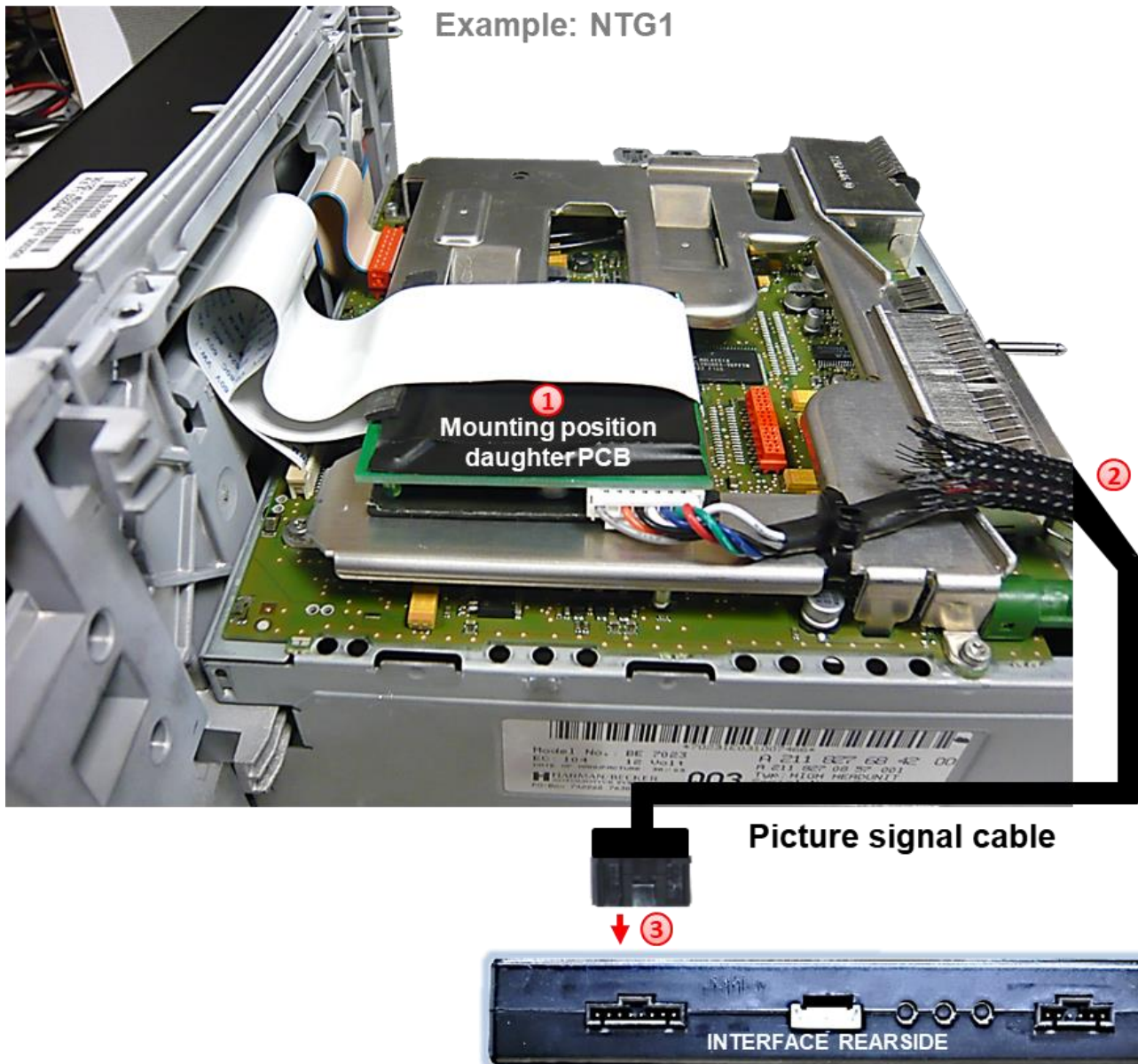

- 1 Position the daughter PCB according to the mounting position shown above.
- 2 Lead the picture signal cable, connected to the daughter PCB, out of the housing at a suitable point.
- 3 Connect the enclosed picture signal cable's female 8pin connector, connected to the daughter PCB, to the male 8pin connector of the video interface.

## 2.6. Connection - Video-sources

It is possible to connect two after-market video sources and one after-market rear-view camera to the video-interface.

**Before final installation of the peripheral devices, we recommend a test-run to detect a incompatibility of vehicle and interface. Due to changes in the production of the vehicle manufacturer there's always a possibility of incompatibility.**

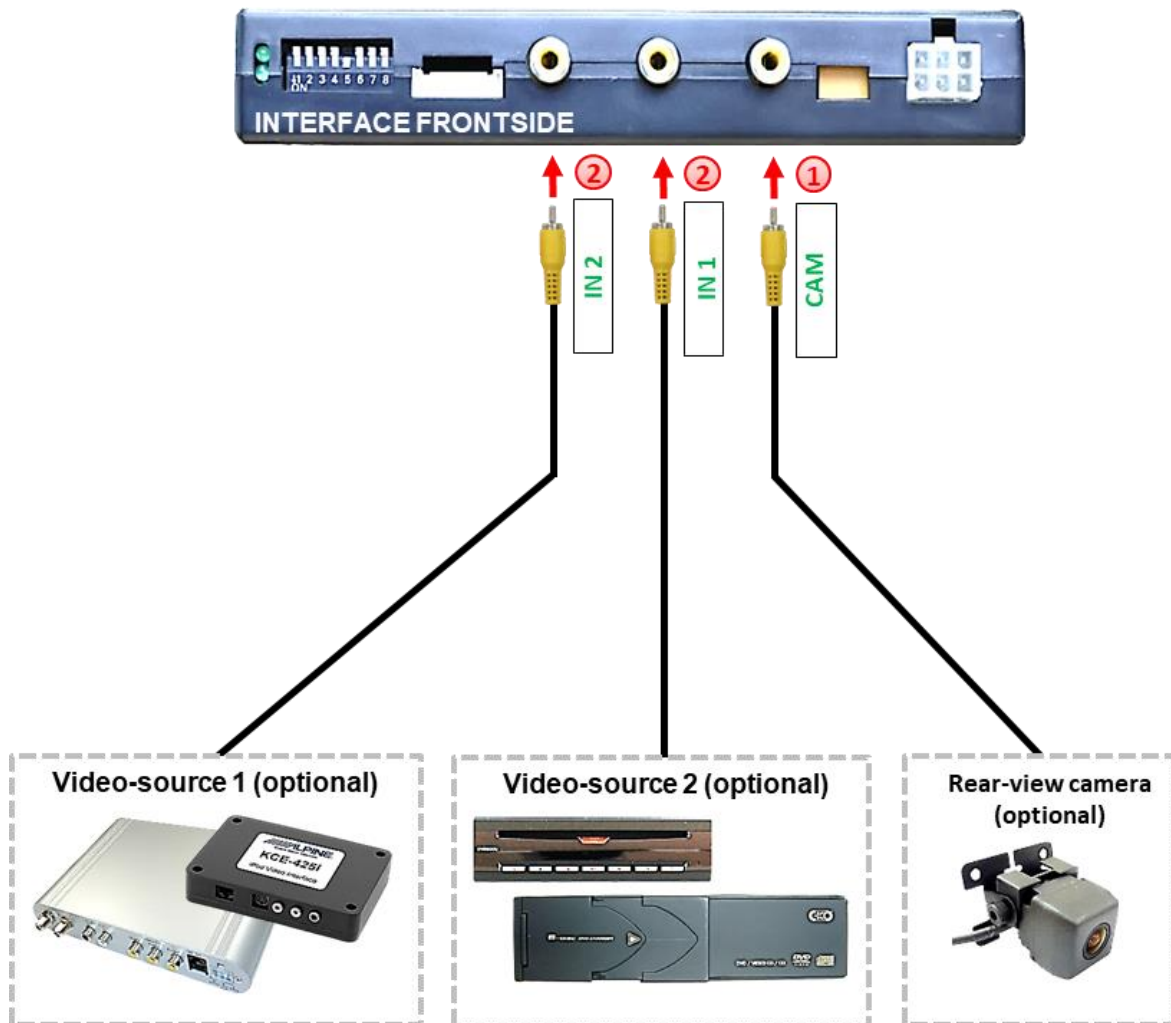

- 1 Connect the rear-view camera's RCA to the female RCA „CAM“ of the video cable.
- 2 Connect the RCA of the video source 1 and video source 2 to the female RCA „IN1“ and „IN2“ of the video cable.

## 2.7. Audio-switch and audio-insertion

This interface is only able to insert video signals into the factory infotainment and switch audio signals. If an AV-source is connected to IN1 or IN2, audio insertion must be done by factory audio AUX input, FM-modulator or AUX-in interface AUX-110 to which the interface's sound-switch output is connected. When the interface is switched from IN1 to IN2, the audio signal is switched parallel to the corresponding video signal by the interface's built-in audio-switch. The inserted video-signal can be activated simultaneously to each audio-mode of the factory infotainment.

Audio pins	Definition
1/2	Audio input signal R/L of source AV2
3/4	Audio input signal R/L of source AV1
5/6	Audio output signal R/L for factory audio AUX or FM-modulator
7	Ground

**Note:** If only one AV-source shall be connected, it is possible to connect the audio output of the AV-source directly to the point of audio-insertion (e.g. audio AUX input).

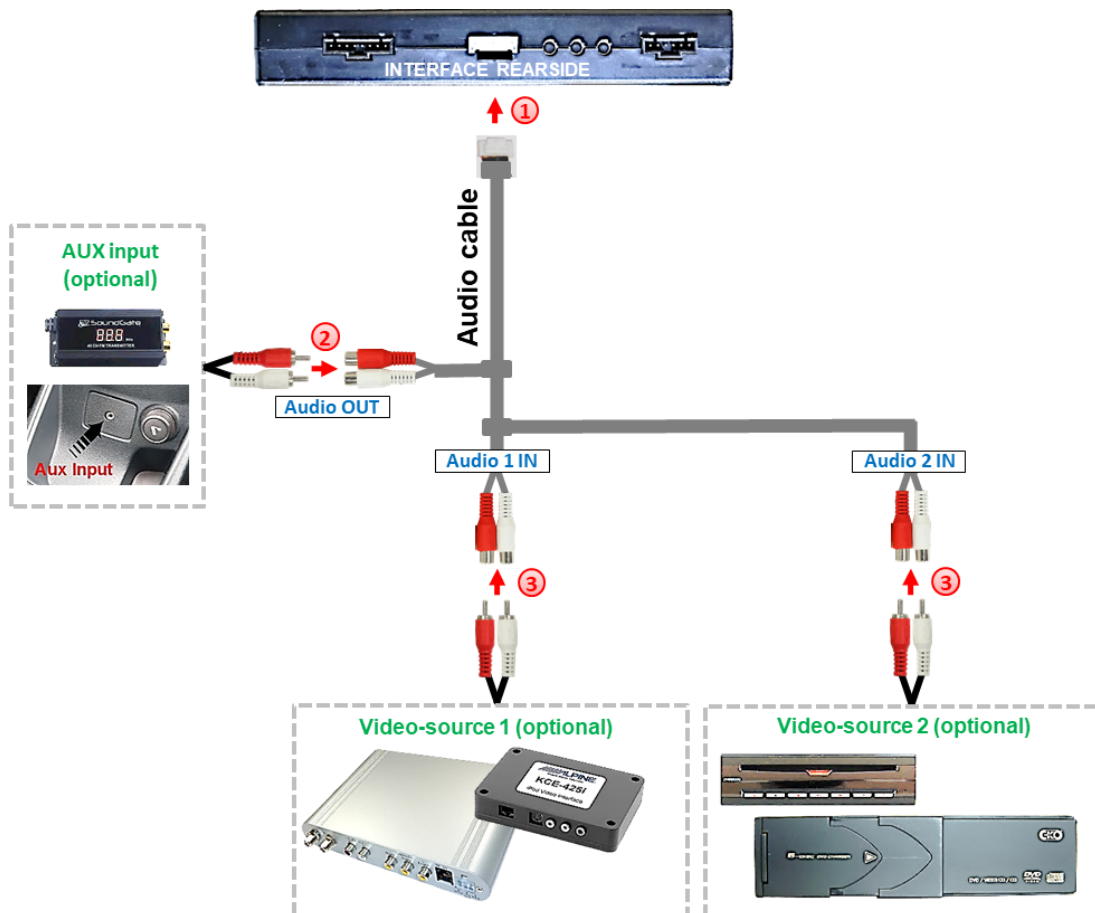

- 1 Connect the audio cable's female 7pin connector to the male 7pin connector of the video-interface.
- 2 Connect the audio-RCA of the possibly existing factory AUX-input or the FM-modulator to the audio cable's female RCA port "Audio OUT".
- 3 Connect the audio-RCA of AV-source 1 and AV source 2 to the female RCA port of the audio cable's „Audio 1 IN“ und „Audio 2 IN“.

## 2.8. After-market rear-view camera

For the connection of a rear-view camera, an external switching signal from the reverse gear light is required. As the reverse gear light signal contains electronic interference, a traditional open relay (e.g. AC-RW-1230 with wiring AC-RS5) or filter (e.g. AC-PNF-RVC) is required. Below schema shows the use of a relay (normally open).

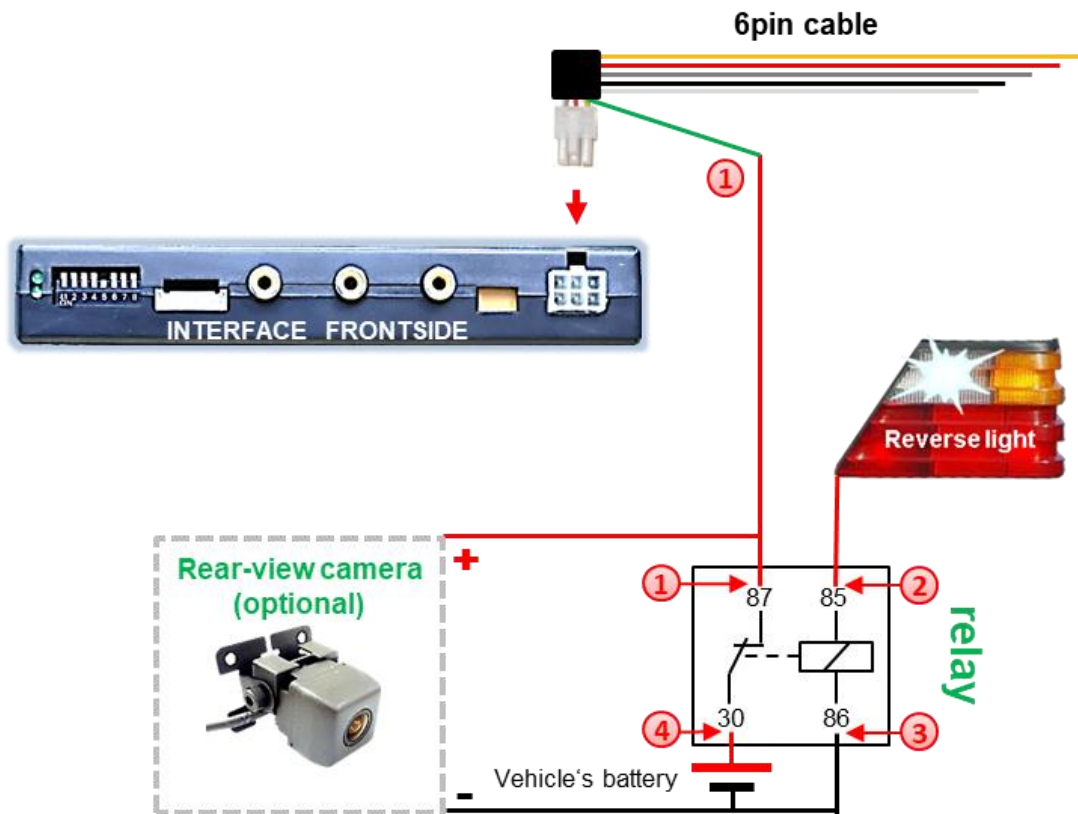

- 1 Connect the rear-view camera power wire and the green wire of the 6pin cable both to output terminal (87) of the relay.
- 2 Connect the reverse gear light signal/power to coil terminal (85).
- 3 Connect vehicle's ground to coil terminal (86) of relay.
- 4 Connect permanent battery power to input terminal (30) of relay.

## 2.9. Connection - video-interface and external keypad

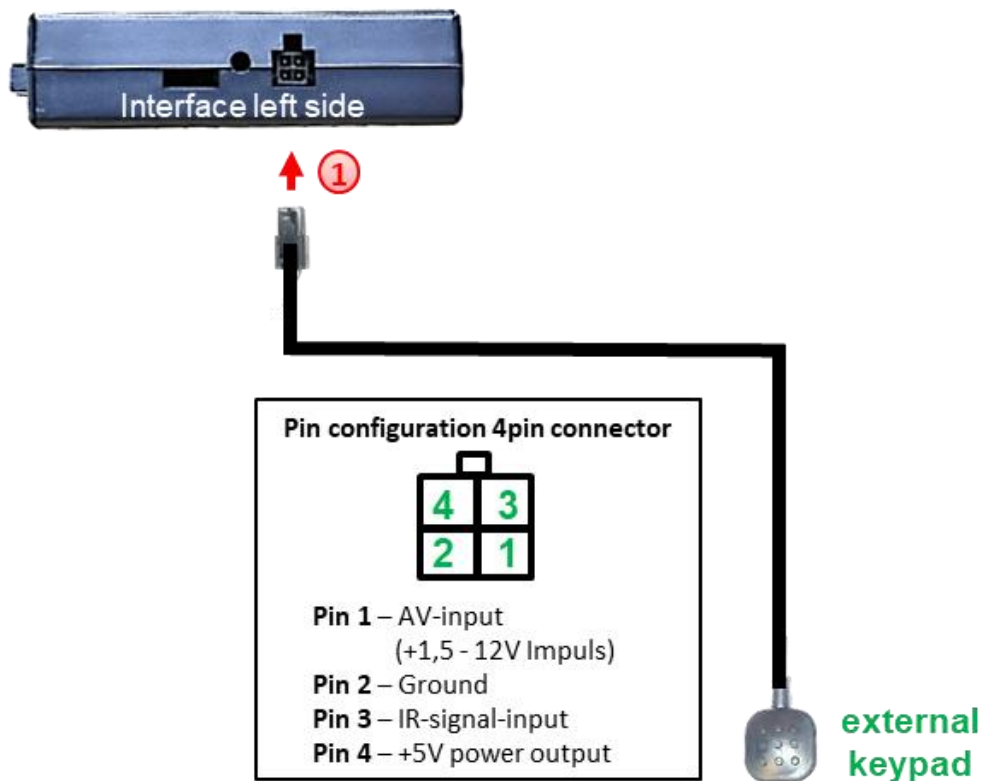

- ① Connect the keypad's female 4pin connector to the video-interface's male 4pin connector.

**Note:** Even if the switching through several video sources could be done by using the white wire instead of the external keypad, the keypad's invisible connection and availability is strongly recommended.

## 2.10. Picture settings

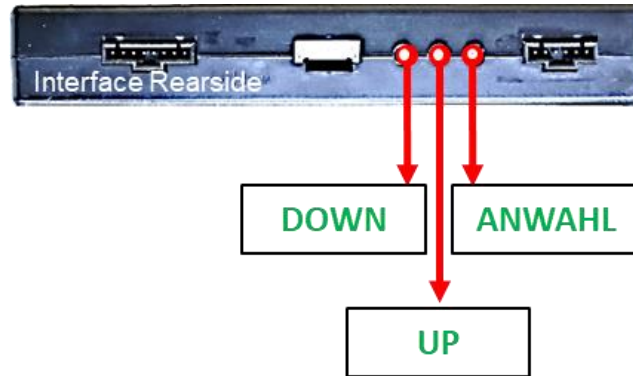

The settings for image brightness and image contrast can be changed by using the 3 buttons on the video interface. A short press of the right button "**Down**" opens the settings menu.

### Adjust picture brightness:

The left button "**Menu**" decreases the image brightness.

The middle button "**UP**" increases the picture brightness.

### Adjust image contrast:

The left button "**Menu**" decreases the image contrast.

The middle button "**UP**" increases the image contrast.

The buttons are recessed in the housing to prevent unintentional changes during and after installation.

The image settings must be made separately for IN1 and IN2 while the corresponding input is selected and visible on the monitor. **IN2 and CAM share the same settings, which must be made on IN2.**

**Note:** Please adjust while a working video source is connected to the selected video-input of the interface.

## 3. Video interface operation

### 3.1. By external keypad

The interface's external keypad can be used to switch the enabled inputs, same as the white wire).

If all inputs are enabled the order is:

*Factory video → video IN1 → video IN2 → factory video →...*

Disabled inputs will be skipped. While switching from **IN1** to **IN2** the audio-source will be switched too, assuming the sources have also been connected to the audio cable.

### 3.2. By white wire of the 6pin cable

Alternatively or additionally to the external keypad, the white wire of the 6pin cable can be used to switch the enabled inputs.

Each +5-12V pulse switches the video interface to the next enabled input.

## 4. Specifications

BATT/ACC range	7V - 25V
Stand-by power drain	27mA
Power	230mA
Video input	0.7V - 1V
Video input formats	NTSC
RGB-video amplitude	0.7V with 75 Ohm impedance
Temperature range	-40°C to +85°C
Dimensions video-box	160 x 25 x 102 mm (W x H x D)

## 5. FAQ – Trouble shooting Interface functions

For any troubles which may occur, check the following table for a solution before requesting support from your vendor.

Symptom	Reason	Possible solution
No picture/black picture (factory picture).	Not all connectors have been reconnected to factory head-unit or monitor after installation.	Connect missing connectors.
	No power on CAN-bus box (all LED CAN-bus box are off).	Check power supply of CAN-bus box. Check CAN-bus connection of CAN-bus box.
	CAN-bus box connected to CAN-bus in wrong place.	Refer to the manual where to connected to the CAN-bus. If not mentioned, try another place to connect to the CAN-bus.
	No power on video-interface (all LED video-interface are off).	Check whether CAN-bus box delivers +12V ACC on red wire output of 8pin to 6pin cable. If not cut wire and supply ACC +12V directly to video-interface.
No picture/black picture/white picture (inserted picture) but factory picture is OK.	No picture from video source.	Check on other monitor whether video source is OK.
	No video-source connected to the selected interface input.	Check settings dips 1 to 3 of video interface which inputs are activated and switch to corresponding input(s).
	LVDS cables plugged in wrong place.	Double-check whether order of LVDS cables is exactly connected according to manual. Plugging into head-unit does not work when the manual says to plug into monitor and vice versa.
	Wrong monitor settings of video-interface.	Try different combinations of dips 7 and 8 of video-interface. Unplug 6pin power after each change.
Inserted picture totally wrong size or position.	Wrong monitor settings of video-interface.	Try different combinations of dips 7 and 8 of video-interface. Unplug 6pin power after each change.
Inserted picture double or 4 times on monitor.		
Inserted picture distorted, flickering or running vertically.	Video sources output set to AUTO or MULTI which causes a conflict with the interfaces auto detection.	Set video source output fixed to PAL or NTSC. It is best to set all video sources to the same standard.
	If error occurs only after source switching: Connected sources are not set to the same TV standard.	Set all video sources to the same standard.
	Some interfaces can only handle NTSC input.	Check manual whether there is a limitation to NTSC mentioned. If yes, set source fixed to NTSC output.
Inserted picture b/w.	Picture settings have not been adjusted.	Use the 3 buttons and the interface's OSD to adjust the picture settings for the corresponding video input.
Inserted picture qual. bad.		
Inserted picture size slightly wrong.		
Inserted picture position wrong.		
Camera input picture flickers.	Camera is being tested under fluorescent light which shines directly into the camera.	Test camera under natural light outside the garage.
Camera input picture is bluish.	Protection sticker not removed from camera lens.	Remove protection sticker from lens.

Symptom	Reason	Possible solution
Camera input picture black.	Camera power taken directly from reverse gear lamp.	Use relay or electronics to "clean" reverse gear lamp power. Alternatively, if CAN-bus box is compatible with the vehicle, camera power can be taken from green wire of 6pin to 8pin cable.
Camera input picture has distortion.		
Camera input picture settings cannot be adjusted.	Camera input picture settings can only be adjusted in AV2 mode.	Set dip 3 of video-interface to ON (if not input AV2 is not already activated) and connect the camera to AV2. Switch to AV2 and adjust settings. Reconnect camera to camera input and deactivate AV2 if not used for other source.
Graphics of a car in camera input picture.	Function PDC is ON in the interface OSD.	In compatible vehicles, the graphics will display the factory PDC distance. If not working or not wanted, set interface OSD menu item UI-CNTRL to ALLOFF.
Chinese signs in camera input picture	Function RET or ALL is ON (function for Asian market) in the interface OSD.	Set interface OSD menu item UI-CNTRL to ALLOFF or PDCON.
Not possible to switch video sources by OEM button.	CAN-bus interface does not support this function for vehicle.	Use external keypad or cut white wire of 6pin to 8pin cable and apply +12V impulses for AV-switching.
Not possible to switch video sources by external keypad.	Pressed too short.	For video source switching a longer press of about 2.5 seconds is required.
	SW-version of interface does not support external keypad.	Use OEM-button or cut white wire of 6pin to 8pin cable and apply +12V impulses for AV-switching.
Interface does not switch to camera input when reverse gear is engaged.	CAN-bus interface does not support this function for the vehicles.	Cut the green wire of the 6pin to 8pin cable and apply +12V constant from reverse gear-lamp signal. Use relay to "clean" R-gear lamp power.
Interface switches video-sources by itself.	CAN-bus interface compatibility to vehicle is limited.	Cut the grey wire of 6pin to 8pin and isolate both ends. If problem still occurs, additionally cut the white wire of 6pin to 8pin cable and isolate both ends.

## 6. Technical Support

Please note that direct technical support is only available for products purchased directly from NavLinkz GmbH. For products bought from other sources, contact your vendor for technical support.

**NavLinkz GmbH**  
**distribution/tech dealer-support**  
 Heidberghof 2  
 D-47495 Rheinberg

Tel +49 2843 17595 00  
 Email mail@navlinkz.de



Made in China