

Video-inserter VL2-LR14-OPS

Compatible with
Land Rover vehicles
with touch-screen infotainment version 3
or
touch-screen infotainment 3.1 with 8inch 16:9 monitor
with touch-screen menu 3

Jaguar Fahrzeuge
with touch-screen infotainment version 3 and version 3.1



example

Video-inserter with 2 video inputs + rear-view camera input

Product features

- Video-inserter for factory-infotainment systems
- 1 CVBS Rear-view camera video-input
- 2 CVBS video-inputs for after-market devices (e.g. USB-Player, DVB-T2 tuner, ...)
- Built-in audio-switch (no audio-insertion)
- Automatic switching to rear-view camera input on engagement of the reverse gear
- Activatable parking guidelines for rear-view camera (not available for all vehicles)
- Activatable PDC (not available for all vehicles)
- Video-in-motion (ONLY for connected video-sources)
- Video-inputs NTSC compatible

Contents

1. Prior to installation

- 1.1. Delivery contents
- 1.2. Checking the compatibility of vehicle and accessories
- 1.3. Boxes and connectors
 - 1.3.1. Video-Interface
 - 1.3.2. CAN-bus box
 - 1.3.3. Dip-switch settings – interface (8dip – black)
 - 1.3.3.1. Enabling the interface's video inputs (dip 2-3)
 - 1.3.3.2. Rear-view camera setting (dip 5)
 - 1.3.3.3. Touch panel version (dip6)
 - 1.3.3.4. Monitor specific settings (dip7)
 - 1.3.3.5. PDC adjustments (Dip-8)
 - 1.3.4. Dip-switch settings – CAN box (4dip – red)

2. Installation

- 2.1. Place of Installation – video interface and CAN-bus box
- 2.2. Connection schema
- 2.3. Installation – daughter PCB
- 2.4. Connection – daughter PCB
- 2.5. Connection - video-interface to Power/CAN
- 2.6. Analogue connection - video-interface
- 2.7. Connection – picture signal cable
- 2.8. Connection – video sources
- 2.9. Audio-switch and audio-insertion
- 2.10. After-market rear-view camera
 - 2.10.1. . Case 1: CAN-box receives the reverse gear signal
 - 2.10.2. . Case 2: CAN-box does not receive the reverse gear signal
- 2.11. Connection – video interface to external keypad
- 2.12. Picture settings and guidelines

3. Video interface operation

- 3.1. By infotainment button
- 3.2. By external keypad
- 3.3. By white wire of the 6pin cable

4. Specifications

5. FAQ – Trouble Shooting-Interface functions

6. Technical support

Legal Information

By law, watching moving pictures while driving is prohibited, the driver must not be distracted. We do not accept any liability for material damage or personal injury resulting, directly or indirectly, from installation or operation of this product. Apart from using this product in an unmoved vehicle, it should only be used to display fixed menus or rear-view-camera video when the vehicle is moving (for example the MP3 menu for DVD upgrades).

Changes/updates of the vehicle's software can cause malfunctions of the interface. Up to one year after purchase we offer free software-updates for our interfaces. To receive a free update, the interface has to be sent in at own cost. Wages for de-and reinstallation and other expenditures involved with the software-updates will not be refunded.

No liability for vehicle wire colours and pin definition!

Changes by the vehicle manufacturer are possible. The given information has to be verified by the installer.

1. Prior to installation

Read the manual prior to installation. Technical knowledge is necessary for installation. The place of installation must be free of moisture and away from heat sources.

1.1. Delivery contents



1.2. Checking the compatibility of vehicle and accessories

Requirements

Brand	Compatible vehicles	Infotainment
Jaguar	XF X250 model year 2012-2013 XJ X351 model year 2010-2013	Touch-screen navi version 3 (resistive touch)
	F-Type model year 2013-2015 XF X250 model year 2014-2015 XJ X351 model year 2014-2015	Touch-screen navi version 3.1 (capacitive touch)
Land Rover	Range Rover Evoque L538 model year 2012-2013 Range Rover Sport L320 model year 2012-2013 Discovery4 L319 model year 2012-2013 Range Rover L322 model year 2012-2013 Freelander2 L359 model year 2013	Touch-screen infotainment version 3 (resistive touch) with touch-screen menu 3
	Discovery4 model year ab 2014 Discovery Sport model year since 2015 Range Rover Evoque model year since 2014 Range Rover Sport model year 2014-2016 Range Rover model year 2014-2016 Freelander2 model year 2014	Touch-screen infotainment version 3.1 with 8 inch 16:9 monitor (capacitive touch) with touch-screen menu 3 (not 4!)

Limitations:

Video only

The interface inserts ONLY video signals into the infotainment. For inserting Audio signals either the possibly existing factory audio or a FM-modulator can be used.

Factory rear-view camera

Automatically switching-back from inserted video to factory rear-view camera is only possible while the reverse gear is engaged. To delay the switch-back an additional electronic part is required.

Guidelines and PDC

Displayed guidelines and the optical PDC are not available in all vehicles.

Video input signal

NTSC video sources compatible only.

1.3. Boxes and connectors

1.3.1. Video Interface

The video-interface converts the video signals of connected after-market sources in a factory monitor compatible picture signal which is inserted in the factory monitor, by using separate trigger options.

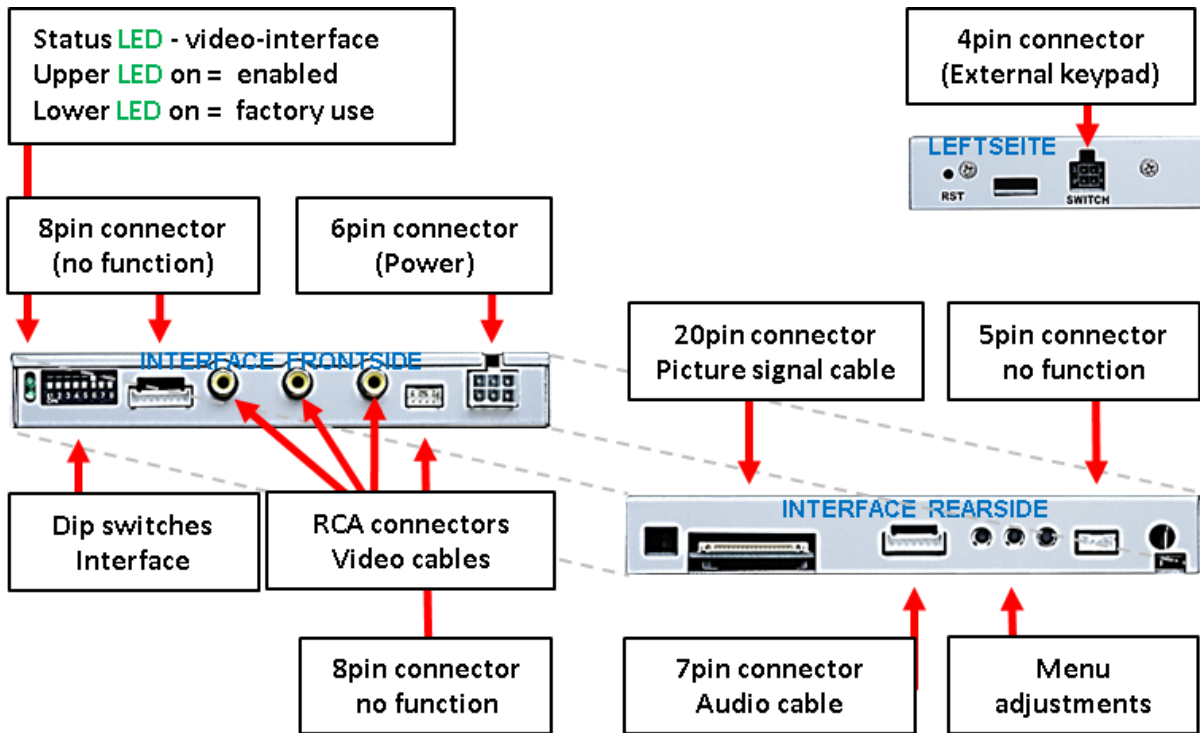

1.3.2. CAN-bus box

The CAN box reads the vehicle's digital signals out of the vehicle's CAN-bus and converts them for the video interface.

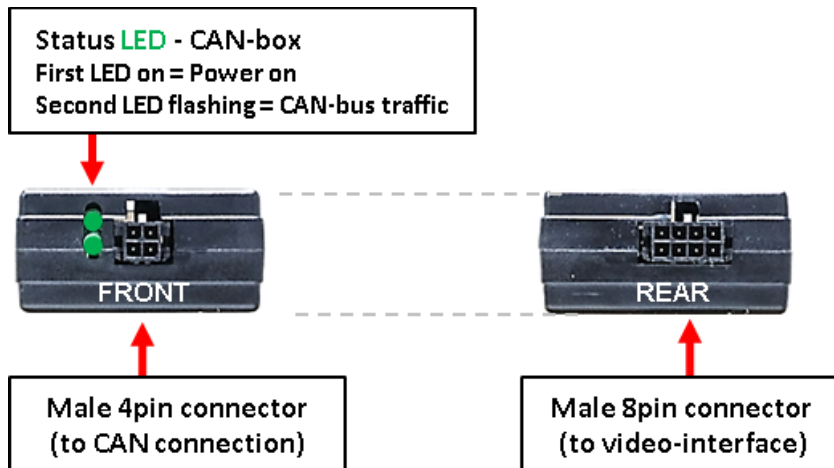

1.3.3. Dip-switch settings – interface (8dip – black)

Some settings have to be selected by the dip-switches on the video interface. Dip position down is ON and position up is OFF.



Dip	Function	ON (down)	OFF (up)
1	No function		set to OFF
2	CVBS AV1-input	enabled	disabled
3	CVBS AV2-input	enabled	disabled
4	No function		set to OFF
5	Rear-view cam type	after-market	factory or none
6	Touch panel version	with resistive touch panel	with capacitive touch panel
7	Monitor size	8inch monitor	7inch monitor
8	PDC	Enabled	disabled

See the following chapters for detailed information.

After each Dip-switch-change a power-reset of the Can-box has to be performed!

1.3.3.1. Enabling the interface's video inputs (dip 2-3)

Only the enabled video inputs can be accessed by switching through the interface's video sources. It is recommended to enable only the required inputs, so the disabled inputs will be skipped while switching through the video interfaces' inputs.

1.3.3.2. Rear-view camera setting (dip 5)

If set to **OFF**, the interface switches to factory LVDS picture while the reverse gear is engaged to display the factory rear-view camera or the factory optical park system picture.

If set to **ON**, the interface switches to its rear-view camera input while the reverse gear is engaged.

1.3.3.3. Touch panel version (Dip 6)

For monitors with resistive touch panels, dip6 has to be set to ON.

For monitors with capacitive touch panels, dip6 has to be set to OFF.

1.3.3.4. Monitor specific settings (Dip 7)

- Dip switch setting **ON** will support the 8inch monitor.
- Dip switch setting **OFF** will support the 7inch monitor.

1.3.3.5. PDC adjustments (dip 8)

If set to ON, the PDC car graphic will be shown on the display. If set to Off, the PDC car graphic will disappear.

Note: Dip 1 und 4 are out of function and have to be set to **OFF**.

1.3.4. Dip-Schalter Einstellungen – CAN box (4dip – red)

Choose the navigation, the interface shall be connected to and set dip 1 to 4 according to the below table.



Fahrzeug/Infotainment	Dip 1	Dip 2	Dip 3	Dip 4
All Range Rover vehicles	ON	ON	ON	ON
Discovery 4	OFF	OFF	ON	OFF
Discovery Sport	ON	ON	OFF	OFF
Freelander 2	OFF	OFF	OFF	ON
Jaguar	ON	ON	ON	ON



Note: The experience values of the CAN bus dip settings are only exemplary. If the Can communication doesn't succeed, try other dip combinations.

After each Dip-switch-change a power-reset of the Video Interface has to be performed!

2. Installation

To install the interface, first switch off the ignition and disconnect the vehicle's battery. Please read the owner's manual of the car, regarding the battery's disconnection! If required, enable the car's Sleep-mode (hibernation mode)

In case the sleep-mode does not succeed, the disconnection of the battery can be done with a resistor lead.

If the necessary stabilized power supply for the interface is not taken directly from the battery, the chosen connection has to be checked for being constantly stable.

The interface needs a permanent 12V source!

2.1. Place of installation – video interface and CAN-bus box

The interface box and the CAN-bus box are prepared to be connected and installed behind the vehicle's head unit.

The daughter PCB is prepared to be connected and installed inside the head unit.

2.2. Connection schema

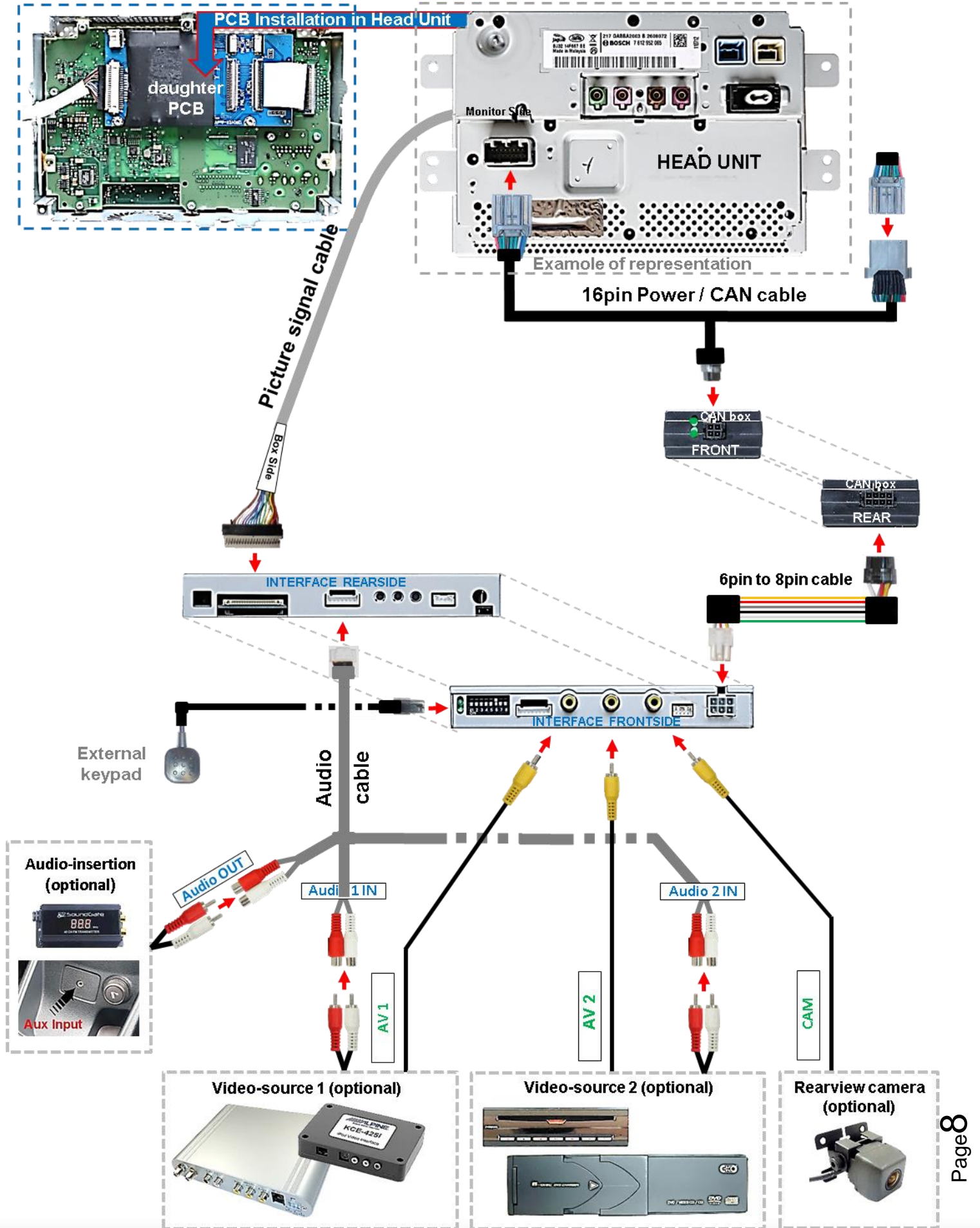

2.3. Installation – daughter PCB

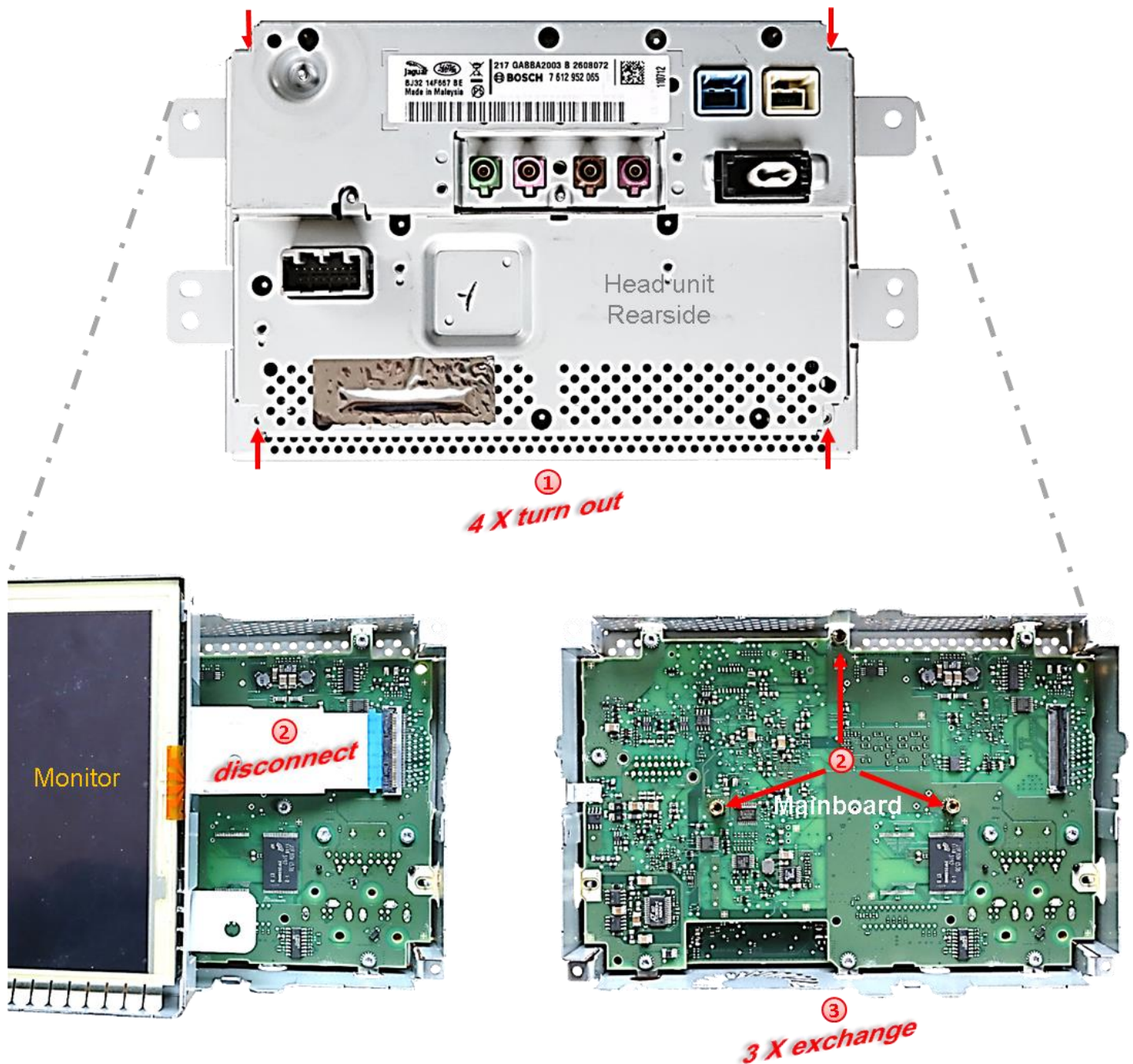

- 1 Turn out the 4 Torx screws at the rear side of the head unit.
- 2 Turn around the head unit, carefully share the monitor part from the head unit housing, clip out and disconnect the original 50pin ribbon cable and lay the monitor part aside.
- 3 Replace the mainboards original 3Torx screws against the 3 enclosed brass spacers (fix points for daughter PCB).

2.4. Connection – daughter PCB

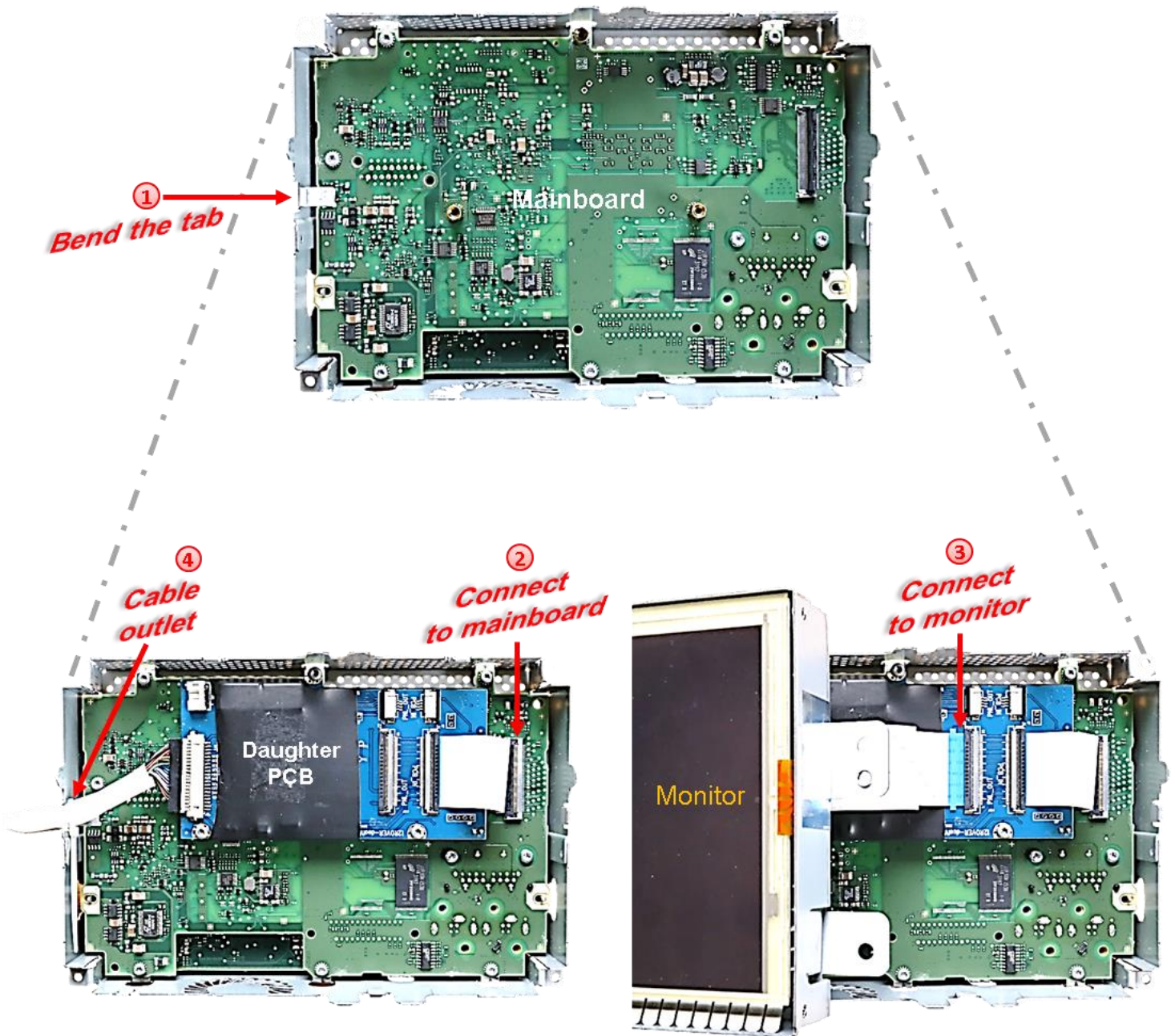

- 1 To support the picture signal cable's final out-leading, bend the left metal housing lab at 90° inwards.
- 2 Connect the daughter PCB's preassembled 50pin ribbon cable to the mainboard's previously become free 50pin ribbon cable base and lock the connection.
- 3 Connect the monitor panel's previously become free 50pin ribbon cable to the daughter PCB's free ribbon cable base and lock the connection.
- 4 With taking care of the previously supported save out-leading for the picture signal cable, stick together the monitor part and the head unit housing (cable tension recommended!).

Finish by fixing the housing with the 4 original Torx screws.

2.5. Connection - video-interface to Power / CAN

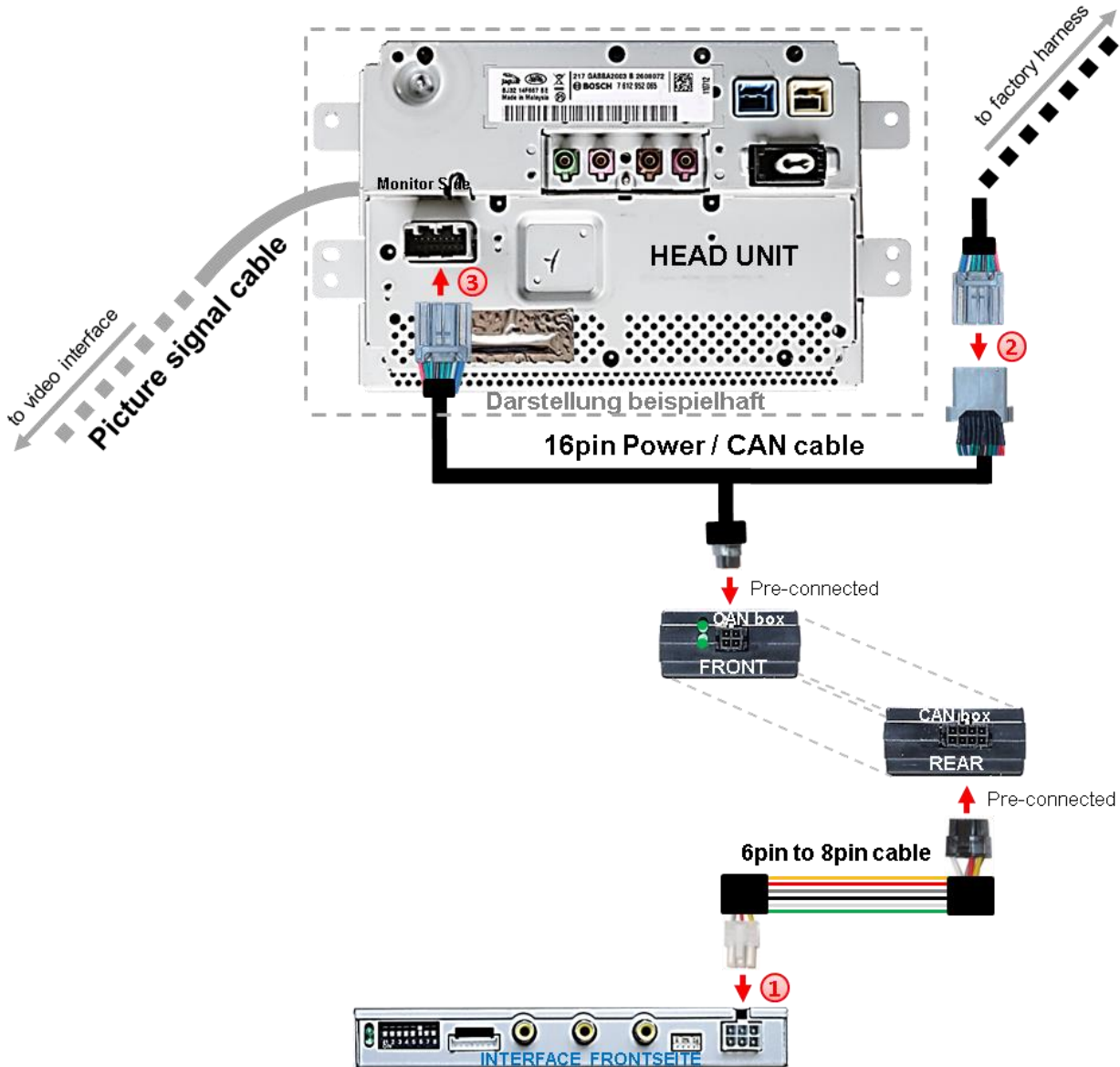

- ① Connect the 6pin to 8pin cable's white female 6pin connector to the male 6pin connector of the video interface.
- ② Disconnect the female 16pin connector of the factory harness at the rear-side of the head unit and connect it to the 16pin Power / CAN cable's male 16pin connector.
- ③ Connect the 16pin Power / CAN cable's opposite female 16pin connector to the head unit's previously become free male 16pin connector.



Exceptionally, the CAN communication may not succeed in all vehicles! If, after LED lightens up while the ignition is turned on, the analog power supply without the CAN box needs to be done! (see following chapter)

2.6. Analogue connecting - video-interface

If the communication between the CAN box and the vehicle's CAN bus does not succeed (not all vehicles are compatible), an analogue connection is required by connecting the 6pin to 8pin cable without the CN box.

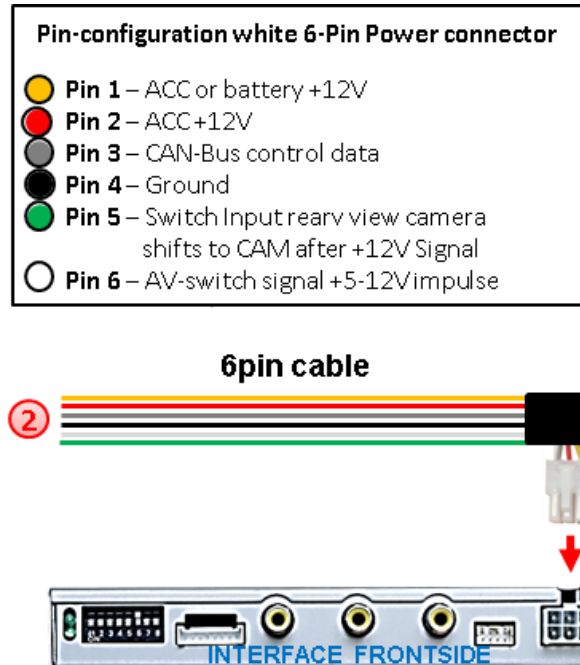

- 1 Connect the female 6pin connector of the 6pin to 8pin cable to the 6pin connector of the video interface.
- 2 Connect the yellow, the red and the black wire of the 6pin to 8pin cable to the vehicle's power and ground.

Note: The connection of the green wire (Reverse signal) will be described in chapter "After-market rear-view camera". The white wire, can be used by +12V impulse to switch the enabled video sources, same as the keypad (see chapter "video interface-operation"). The grey wire remains unconnected.

2.7. Connection - picture signal cable

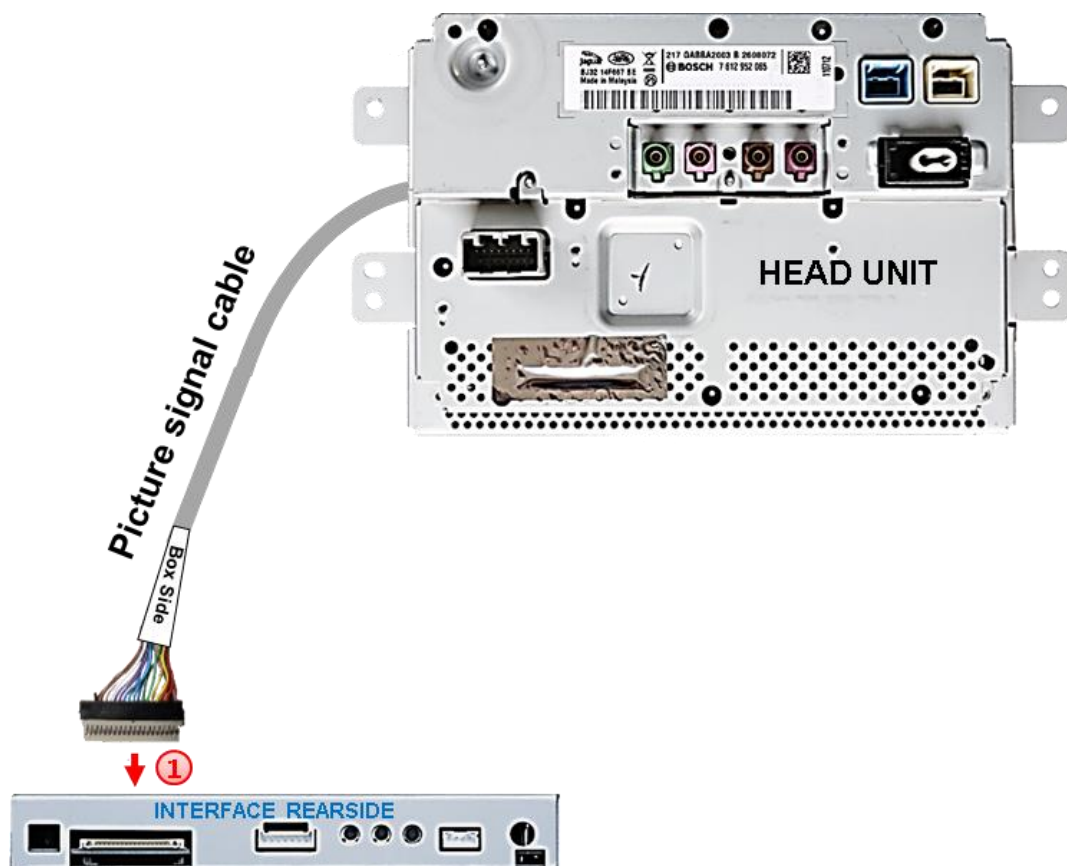

- 1 Connect the female 20pin connector of the picture signal cable—coming from the head unit—to the male 20pin connector of the video interface.

2.8. Connection - Video-sources

It is possible to connect two after-market video sources and one after-market rear-view camera to the video-interface.

Before final installation of the peripheral devices, we recommend a test-run to detect an incompatibility of vehicle and interface. Due to changes in the production of the vehicle manufacturer there's always a possibility of incompatibility.

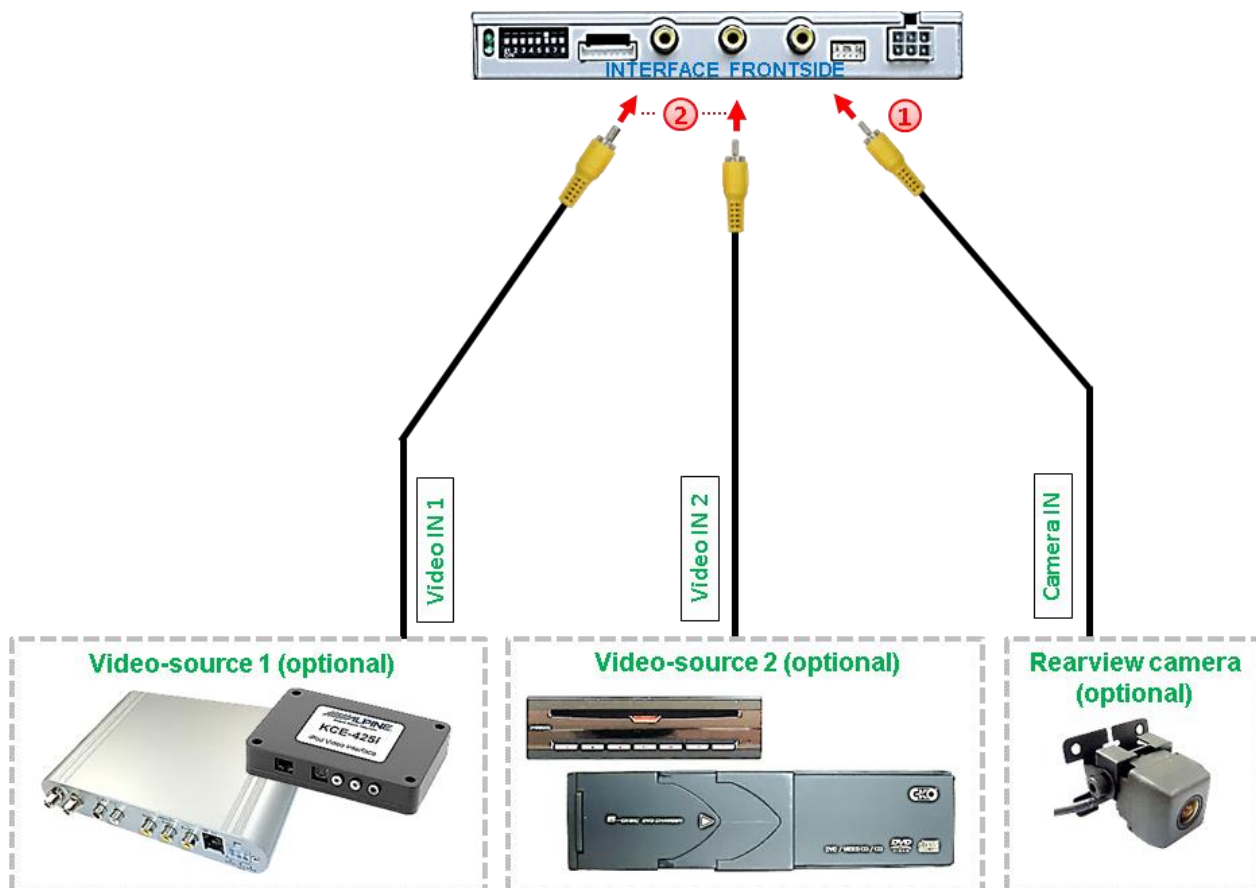

- 1 Connect the rear-view camera's male RCA to the video interface's female RCA „Camera IN“.
- 2 Connect the male RCAs of possibly existing video sources 1 and 2 to the video interface's female RCAs „Video IN1“ and „Video IN2“.

2.9. Audio-switch and audio-insertion

This interface is only able to insert video signals into the factory infotainment and switch audio signals. If an AV-source is connected to AV1 or AV2, audio insertion must be done by factory audio AUX input or FM-modulator to which the interface's sound-switch output is connected. When the interface is switched from AV1 to AV2, the audio signal is switched parallel to the corresponding video signal by the interface's built-in audio-switch. The inserted video-signal can be activated simultaneously to each audio-mode of the factory infotainment.

Audio pins	Definition
1/2	Audio input signal R/L of source AV2
3/4	Audio input signal R/L of source AV1
5/6	Audio output signal R/L for factory audio AUX or FM-modulator
7	Ground

Note: If only one AV-source shall be connected, it is possible to connect the audio output of the AV-source directly to the point of audio-insertion (e.g. audio AUX input).

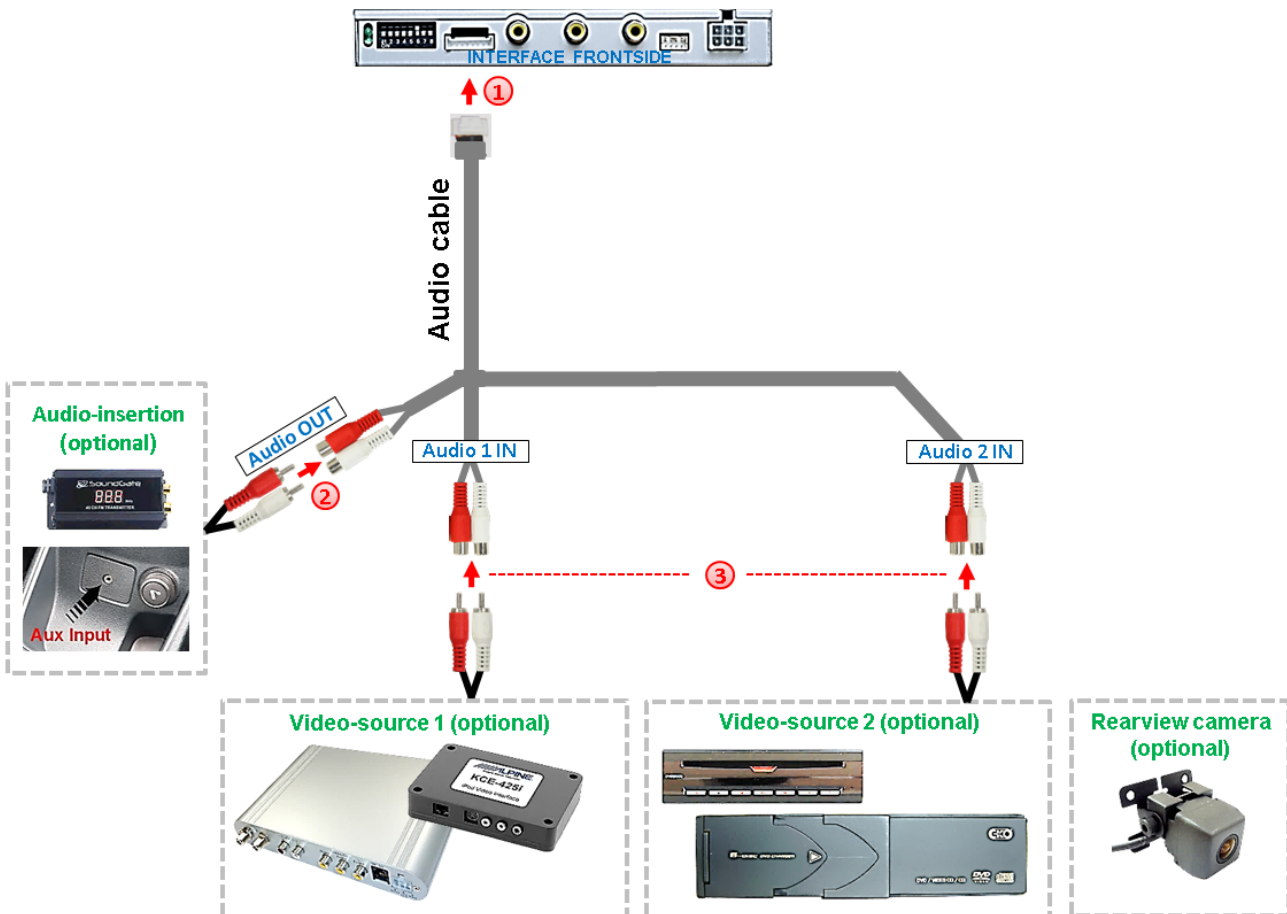

- ① Connect the audio cable's female 7pin connector to the male 7pin connector of the video-interface.
- ② Connect the audio-RCA connectors of possibly existing factory AUX-input or FM-modulator to the audio cable's female RCA "Audio OUT".
- ③ Connect the audio-RCA connectors of possibly existing AV-sources 1 and 2 to the female RCAs of the audio cable's „Audio 1 IN“ und „Audio 2 IN“.

2.10. After-market rear-view camera

Some vehicles have a different reverse gear code on the CAN-bus which the included CAN-box is not compatible with. In this case there are two different ways of installation. If the CAN-box is able to detect an enabled vehicle's reverse gear, the green wire of the 6pin to 8pin cable carries +12V while the reverse gear is engaged.

Note: Do not forget to set dip5 of video-interface to ON before testing.

2.10.1. Case 1: CAN-box receives the reverse gear signal

If the CAN-bus box delivers +12V on the green wire of the 6pin to 8pin cable while reverse gear is engaged, the video interface will automatically switch to the rear-view camera input „CAMERA IN“ while the reverse gear is engaged.

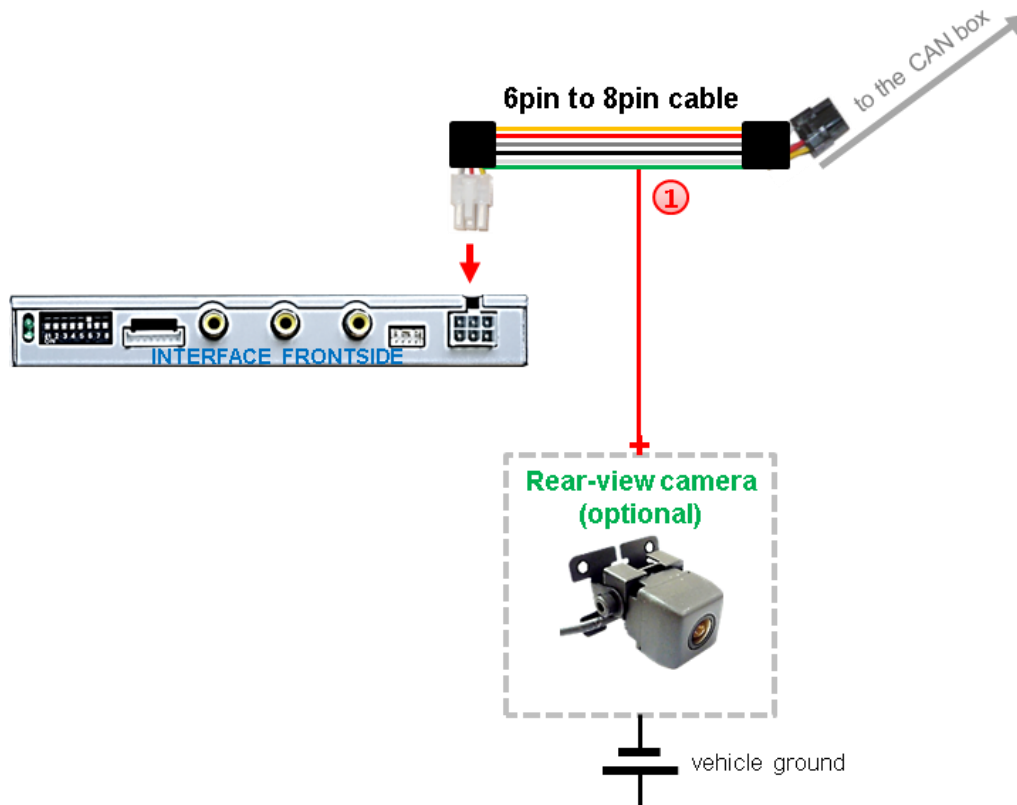

Additionally, the +12V (max. 500mA) power supply for the rear-view camera can be taken from the green wire of the 6pin to 8pin cable.

2.10.2. . Case 2: CAN-box does not receive the reverse gear signal

If the CAN-bus interface does not receive +12V on the green wire of the 6pin to 8pin cable when reverse gear is engaged (not all vehicles are compatible) an external switching signal from the reverse gear light is required. As the reverse gear light signal contains electronic interference, a traditional open relay (e.g AC-RW-1230 with wiring AC-RS5) or filter (e.g. AC-PNF-RVC) is required. Below schema shows the use of a relay (normally open).

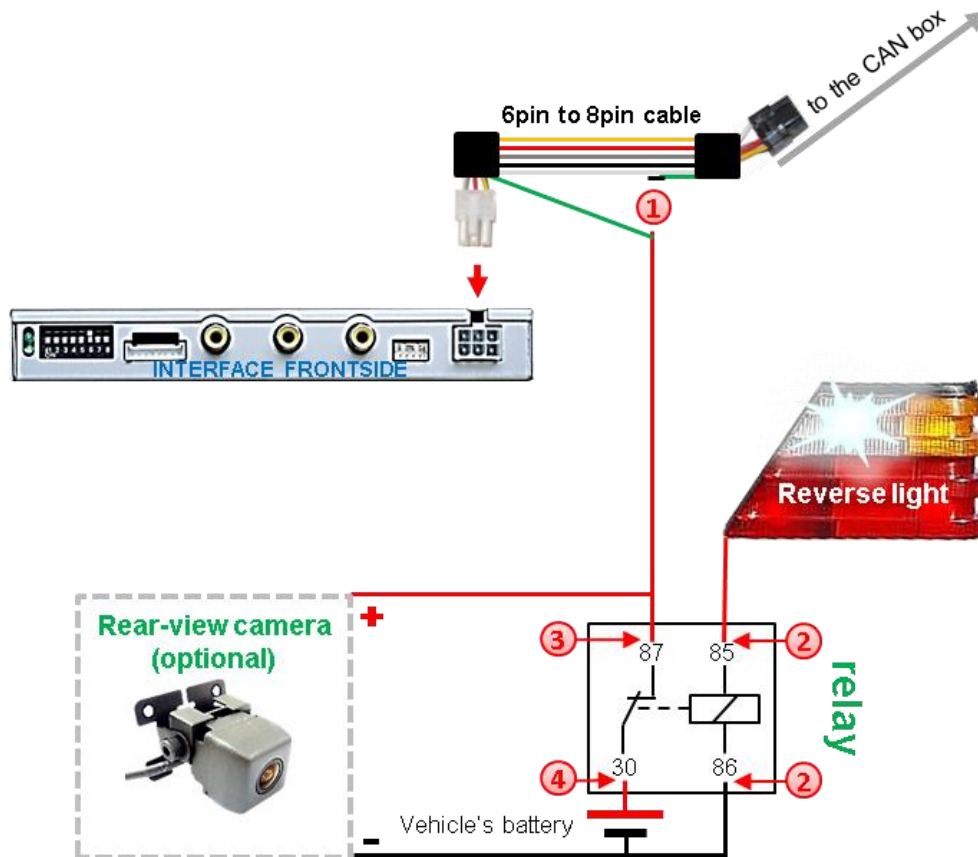

- ① Cut the green cable of the 6pin to 8pin cable close to the black 8pin connector and isolate the shorter end of the green cable near to the 8pin connector (CAN-box side).
- ② Connect the reverse gear light signal/power to coil terminal (85) and vehicle's ground to coil terminal (86) of relay.
- ③ Connect the rear-view camera power wire and the green wire (video interface side) of the 6pin to 8pin cable both to output terminal (87) of the relay.
- ④ Connect permanent battery power to input terminal (30) of relay.



Note: If, due to a missing CAN communication, the 6pin to 8pin cable has been connected the analogue way instead of the Can box, the green wire's connection has also to be done as shown in the picture above.

2.11. Connection - video-interface to external keypad

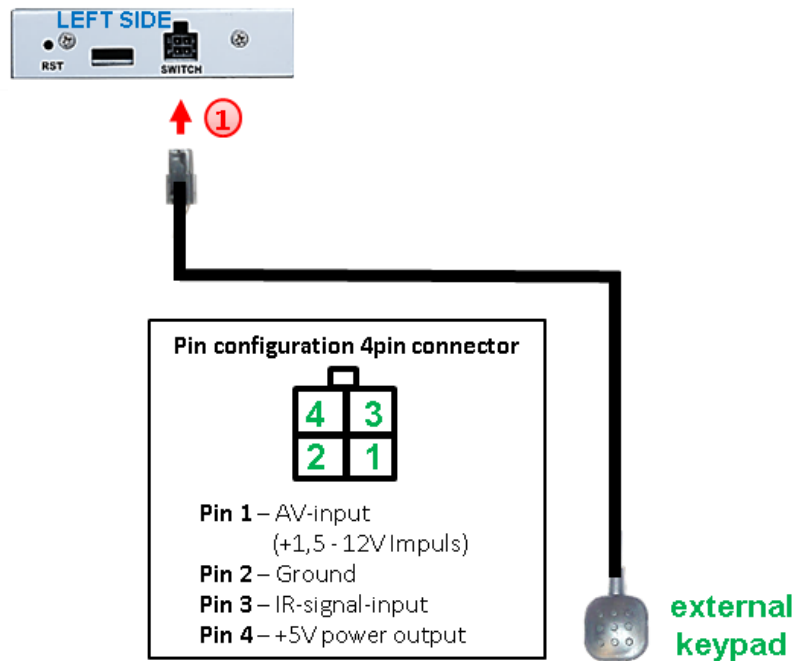

- ① Connect the keypad's female 4pin connector to the video-interface's male 4pin connector.

Note: Even if the switching through several video sources by the keypad mightn't be required, the invisible connection and availability is strongly recommended.

2.12. Picture settings and guidelines

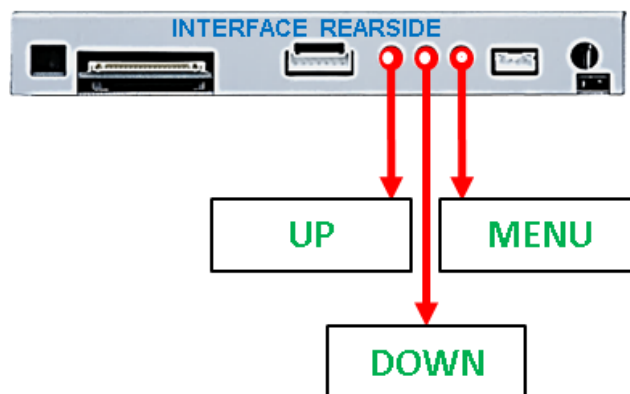

The picture settings are adjustable by the 3 push-buttons on the video-interface. Press the MENU button to open the OSD settings menu or to switch to the next menu item. Press UP and DOWN to change the selected value. The buttons are placed inside in the housing to avoid accidental changes during or after the installation. Picture settings must be done separately for AV1 and AV2 while the corresponding input is selected and visible on the monitor. AV2 and CAM may share the same settings which have to be adjusted in AV2 in this case.

Note: The OSD menu is only shown when a working video source is connected to the selected video-input of the interface.

The following settings are available:

Brightness		
Contrast		
Saturation		
H POS	=	horizontal position
V POS	=	vertical position
IR. AV1		no function
IR. AV2		no function
PDC Offset		PCB picture dragging
Guide line		guide lines ON/OFF

A screenshot of the OSD menu showing the following settings:

```
Brightness...50
Contrast....50
Saturation...50
Position.H...39
Position.V...13
IR.AV1....
IR.AV2....
PDC.Offset...01
Guide.Line...0N
```

Note: If there is no communication between interface and the vehicle's CAN-bus (several vehicles aren't compatible), the reverse gear guide-lines can't be shown during the vehicle's operation, even if they once appear after having switched the system to powerless!

3. Video interface operation

3.1. By infotainment buttons

To switch the video sources

- in **Range Rover** vehicles, the **MENU** button or the **Navi** button
- in **Discovery 4** vehicles, the **HOME** button, the **Menü** button oder the **Navi** button
- in **Discovery Sport** vehicles, the **Navi** button
- in **Freelander vehicles**, the **HOME** button, die **Menü** button oder die **Navi** button can be used.

In Jaguar vehicles, the external keypad has to be used.

A long press of the button switches to the next activated video input. If all inputs are enabled the order is:

Factory video → video IN1 → video IN2 → factory video →...

Disabled inputs will be skipped. While switching from **Video IN1** to **Video IN2** the audio-source will be switched too, assuming the sources have also been connected to the audio cable.

Switchover by vehicle buttons isn't possible in all vehicles. In some vehicles the external keypad or the 6pin cable's white wire has to be used (see following chapters).

3.2. By external keypad

Alternatively or additionally to the factory infotainment buttons, the interface's external keypad can be used to switch the enabled inputs.

3.3. By white wire of the 6pin cable

Alternatively or additionally to the factory infotainment buttons, the 6pin cable's white wire can be used to switch the enabled inputs (with +5V or +12V impulse).

4. Specifications

BATT/ACC range	7V - 25V
Stand-by power drain	30mA
Power	180mA
Video input	0.7V - 1V
Video input formats	NTSC
RGB-video amplitude	0.7V with 75 Ohm impedance
Temperature range	-40°C to +85°C
Dimensions video-box	157 x 21 x 100 mm (B x H x T)
Dimensions CAN-box	72 x 22 x 43 mm (B x H x T)

5. FAQ – Trouble shooting Interface functions

For any troubles which may occur, check the following table for a solution before requesting support from your vendor.

Symptom	Reason	Possible solution
No picture/black picture (factory picture).	Not all connectors have been reconnected to factory head-unit or monitor after installation.	Connect missing connectors.
	No power on CAN-bus box (all LED CAN-bus box are off).	Check power supply of CAN-bus box. Check CAN-bus connection of CAN-bus box.
	CAN-bus box connected to CAN-bus in wrong place.	Refer to the manual where to connected to the CAN-bus. If not mentioned, try another place to connect to the CAN-bus.
	No power on video-interface (all LED video-interface are off).	Check whether CAN-bus box delivers +12V ACC on red wire output of 8pin to 6pin cable. If not cut wire and supply ACC +12V directly to video-interface.
No picture/black picture/white picture (inserted picture) but factory picture is OK.	No picture from video source.	Check on other monitor whether video source is OK.
	No video-source connected to the selected interface input.	Check settings dips 1 to 3 of video interface which inputs are activated and switch to corresponding input(s).
	LVDS cables plugged in wrong place.	Double-check whether order of LVDS cables is exactly connected according to manual. Plugging into head-unit does not work when the manual says to plug into monitor and vice versa.
Inserted picture totally wrong size or position.	Wrong monitor settings of video-interface.	Try different combinations of dips 7 and 8 of video-interface. Unplug 6pin power after each change.
Inserted picture double or 4 times on monitor.		
Inserted picture distorted, flickering or running vertically.	Video sources output set to AUTO or MULTI which causes a conflict with the interfaces auto detection.	Set video source output fixed to PAL or NTSC. It is best to set all video sources to the same standard.
	If error occurs only after source switching: Connected sources are not set to the same TV standard.	Set all video sources to the same standard.
	Some interfaces can only handle NTSC input.	Check manual whether there is a limitation to NTSC mentioned. If yes, set source fixed to NTSC output.
Inserted picture b/w.	Picture settings have not been adjusted.	Use the 3 buttons and the interface's OSD to adjust the picture settings for the corresponding video input.
Inserted picture qual. bad.		
Inserted picture size slightly wrong.		
Inserted picture position wrong.		
Camera input picture flickers.	Camera is being tested under fluorescent light which shines directly into the camera.	Test camera under natural light outside the garage.
Camera input picture is bluish.	Protection sticker not removed from camera lens.	Remove protection sticker from lens.

Symptom	Reason	Possible solution
Camera input picture black.	Camera power taken directly from reverse gear lamp.	Use relay or electronics to "clean" reverse gear lamp power. Alternatively, if CAN-bus box is compatible with the vehicle, camera power can be taken from green wire of 6pin to 8pin cable.
Camera input picture has distortion.		
Camera input picture settings cannot be adjusted.	Camera input picture settings can only be adjusted in AV2 mode.	Set dip 3 of video-interface to ON (if not input AV2 is not already activated) and connect the camera to AV2. Switch to AV2 and adjust settings. Reconnect camera to camera input and deactivate AV2 if not used for other source.
Graphics of a car in camera input picture.	Function PDC is ON in the interface OSD.	In compatible vehicles, the graphics will display the factory PDC distance. If not working or not wanted, set interface OSD menu item UI-CNTRL to ALLOFF.
Chinese signs in camera input picture	Function RET or ALL is ON (function for Asian market) in the interface OSD.	Set interface OSD menu item UI-CNTRL to ALLOFF or PDCON.
Not possible to switch video sources by OEM button.	CAN-bus interface does not support this function for vehicle.	Use external keypad or cut white wire of 6pin to 8pin cable and apply +12V impulses for AV-switching.
Not possible to switch video sources by external keypad.	Pressed too short.	For video source switching a longer press of about 2.5 seconds is required.
	SW-version of interface does not support external keypad.	Use OEM-button or cut white wire of 6pin to 8pin cable and apply +12V impulses for AV-switching.
Interface does not switch to camera input when reverse gear is engaged.	CAN-bus interface does not support this function for the vehicles.	Cut the green wire of the 6pin to 8pin cable and apply +12V constant from reverse gear-lamp signal. Use relay to "clean" R-gear lamp power.
Interface switches video-sources by itself.	CAN-bus interface compatibility to vehicle is limited.	Cut the grey wire of 6pin to 8pin and isolate both ends. If problem still occurs, additionally cut the white wire of 6pin to 8pin cable and isolate both ends.

6. Technical Support

Please note that direct technical support is only available for products purchased directly from NavLinkz GmbH. For products bought from other sources, contact your vendor for technical support.

NavLinkz GmbH
distribution/tech dealer-support
 Heidberghof 2
 D-47495 Rheinberg

Tel +49 2843 17595 00
 Email mail@navlinkz.de

 10R-03 5384

Made in China

