

Video-inserter

VL2-NG4-HU

Compatible with
Citroen with NaviDrive RT3evo/4/5,
Maserati with N3 from Magneti Marelli and
Peugeot with WIP Com/
Connect Com RT3 evo/4/5/6
with colour display and
10pin LVDS monitor connector

Only for vehicles with low-resolution monitors

Video-inserter with 2 video + rear-view camera input

Product features

- Video-inserter for factory-infotainment systems
- 2 CVBS video-inputs for after-market devices (e.g. DVD-Player, DVB-T tuner, ...)
- Built-in audio-switch (no audio-insertion)
- Rear-view camera CVBS video-input
- Automatic switching to rear-view camera input on engagement of reverse gear
- Video-in-motion (ONLY for connected video-sources)
- Compatible with factory rear-view camera
- Video-inputs NTSC compatible

Contents

1. Prior to installation

- 1.1. Delivery contents
- 1.2. Checking the compatibility of vehicle and accessories
- 1.3. Boxes and connectors
 - 1.3.1. Video-interface
 - 1.3.2. CAN-bus box
- 1.4. Dip-switch settings
 - 1.4.1. Enabling the interface's video inputs (dip 1-3)
 - 1.4.2. Rear-view camera setting (dip 5)
 - 1.4.3. Monitor selection (dip 7-8)
- 1.5. Dip-switch settings of the CAN-box

2. Installation

- 2.1. Place of installation
- 2.2. Connection schema
- 2.3. Connecting video-interface and CAN-box for Citroen and Peugeot vehicles
- 2.4. Connecting video-interface for vehicles without function of CAN-box
- 2.5. Connection to the head-unit
- 2.6. Connecting peripheral devices
 - 2.6.1. Video-sources to IN1 and IN2
 - 2.6.2. Audio-switch and audio-insertion
 - 2.6.3. After-market rear-view camera
 - 2.6.3.1. Case 1: CAN-box detects reverse gear
 - 2.6.3.2. Switching of picture formats – Activation PIP
 - 2.6.3.3. Case 2: CAN-box does not detect reverse gear
 - 2.6.3.4. Video signal connection
- 2.7. Connecting video-interface and keypad
- 2.8. Picture settings

3. Interface operation

- 3.1. By factory-infotainment-buttons in vehicles with function of CAN box
- 3.2. By keypad

4. Specifications

5. Frequently asked questions

6. Technical support

Legal Information

By law, watching moving pictures while driving is prohibited, the driver must not be distracted. We do not accept any liability for material damage or personal injury resulting, directly or indirectly, from installation or operation of this product. This product should only be used while standing or to display fixed menus or rear-view-camera video when the vehicle is moving, for example the MP3 menu for DVD upgrades.

Changes/updates of the vehicle's software can cause malfunctions of the interface. We offer free software-updates for our interfaces for one year after purchase. To receive a free update, the interface must be sent in at own cost. Labor cost for and other expenses involved with the software-updates will not be refunded.

1. Prior to installation

Read the manual prior to installation.

Technical knowledge is necessary for installation. The place of installation must be free of moisture and away from heat sources.

1.1. Delivery contents

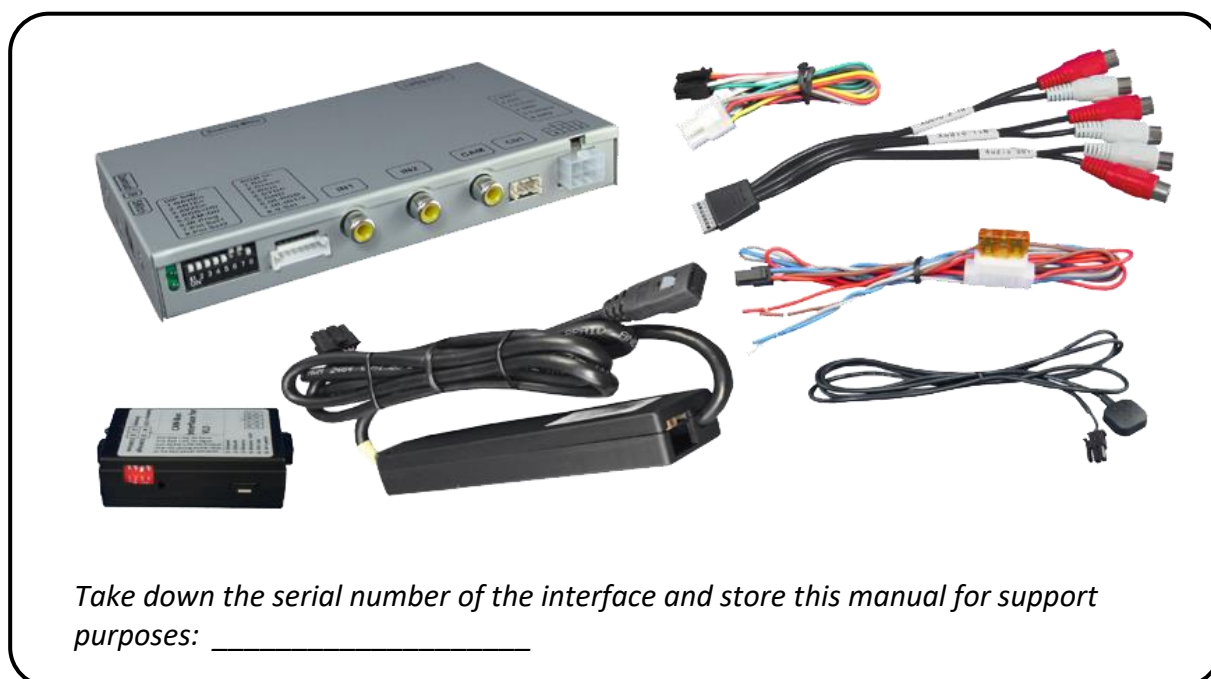

1.2. Checking the compatibility of vehicle and accessories

Requirements		
Brand	Model	Navigation
Citroen	C4 Picasso from 09/2006 until 12/2007, C6 from 09/2005 until 12/2017	NaviDrive RT3evo/4/5 <i>Only for low resolution monitors</i>
Maserati	GranCabrio from 2010 until 2017, GranTurismo from 2007 until 2017, Quattroporte from 2009 until 2012	N3 Magneti Marelli <i>Only for low resolution monitors</i>
Peugeot	1007 from 12/2006 until 12/2007, 307 from 01/2007 until 12/2007, 307CC from 01/2007 until 12/2007, 407 from 10/2006 until 12/2007, 607 from 08/2006 until 12/2007	WIP Com/Connect Com RT3 evo/4/5/6 <i>Only for low resolution monitors</i>

Limitations	
<i>Video only</i>	The interface inserts ONLY video signals into the infotainment. For sound use the possibly existing factory-audio-AUX-input or a FM-modulator.
<i>Factory rear-view camera</i>	Automatic switch-back from inserted video to factory rear-view camera only while reverse gear is engaged. To delay the switch-back time, additional electronics is required.
<i>Video input signal</i>	NTSC video sources compatible only.

1.3. Boxes and connectors

1.3.1. Video-interface

The video-interface converts the connected after-market sources video signals to an LVDS signal which is the inserted into the factory monitor on certain trigger options.

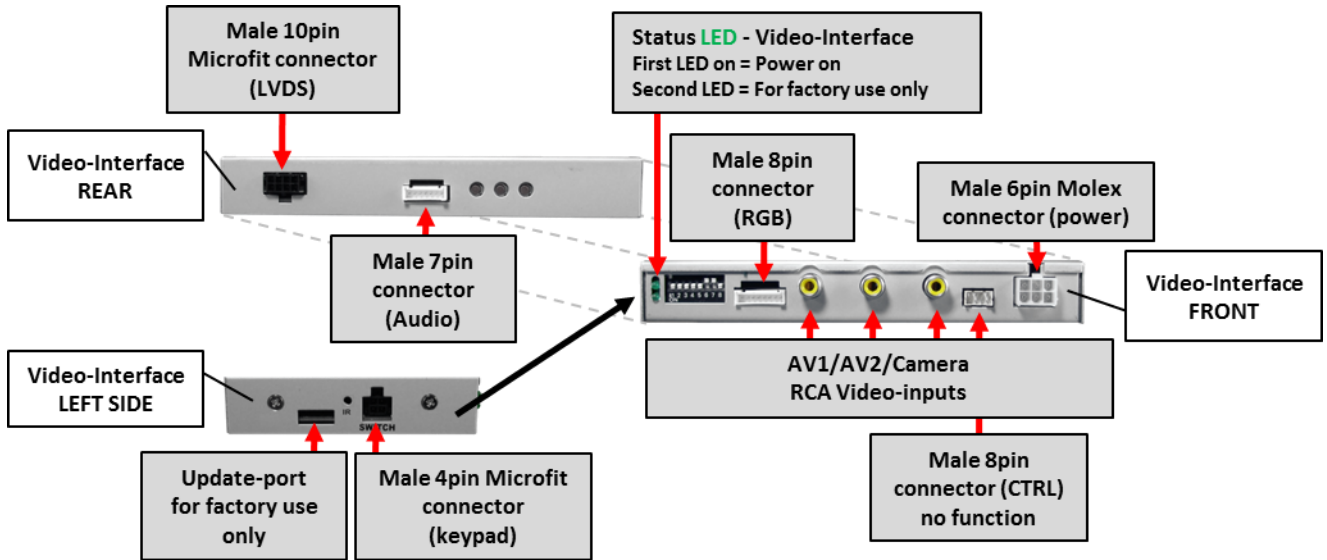

1.3.2. CAN-bus box

The CAN-bus box reads digital signals from the CAN-bus and converts them for the video-interface.

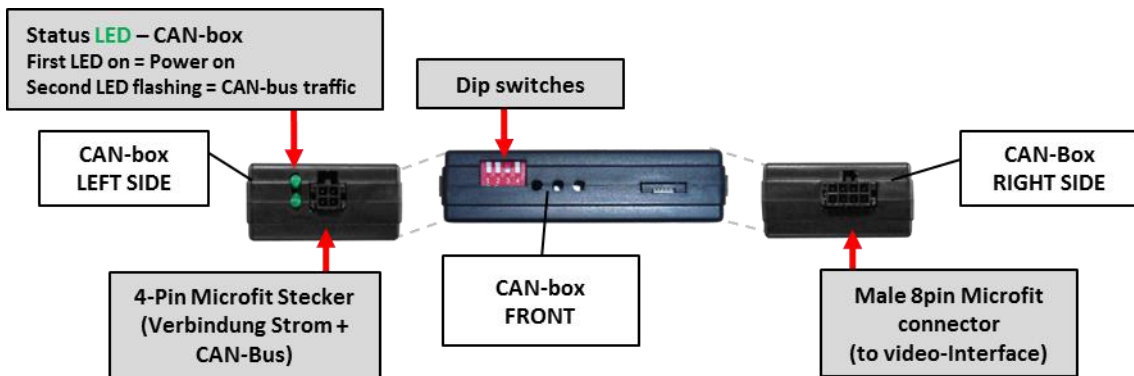

1.4. Dip-switch settings

Some settings must be selected by the dip-switches on the video-interface. Dip position down is ON and position up is OFF.

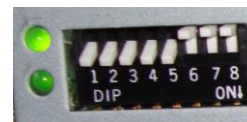

Dip	Function	ON (down)	OFF (up)
1	No function	-	set OFF
2	CVBS AV1-input	enabled	disabled
3	CVBS AV2-input	enabled	disabled
4	No function	-	set OFF
5	Rear-view cam type	after-market	factory or none
6	No function	-	set OFF
7	Monitor selection	Try all 4 possible combinations of dip 7 and 8 to find the best picture (quality and size)	
8			

See following chapters for detailed information.

1.4.1. Enabling the interface's video inputs (dip 1-3)

Only the enabled video inputs can be accessed when switching through the interface's video sources. It is recommended to enable only the required inputs for the disabled will be skipped when switching through the video-interfaces inputs.

1.4.2. Rear-view camera setting (dip 5)

If set to OFF, the interface switches to factory LVDS picture while the reverse gear is engaged to display factory rear-view camera or factory optical park system picture.

If set to ON, the interface switches to its rear-view camera input CAM while the reverse gear is engaged.

1.4.3. Monitor selection (dip 7-8)

Dip 7 and 8 are for monitor-specific video settings which cannot be predicted as even within the same head-unit version, the monitor specifications may vary. It is necessary to try all possible combinations (both OFF, both ON, 7 OFF and 8 ON, 7 ON and 8 OFF) - while a working video source is connected to the chosen input of the interface - to see which combination gives the best picture quality and size (some may give no picture). It is possible to first hot plug through the dip combinations, but if you do not experience any change of picture after trying all 4 options, retry and disconnected the 6pin power plug of the video-box between every change of the dip setting.

Dip1, 4 and 6 are out of function and have to be set to OFF

1.5. Dip-switch settings of the CAN-box

With the CAN-boxes dip-switches it is possible to select vehicle/head-unit the interface is to be installed in.



Dip position down is ON and position up is OFF.

Vehicle/Navigation	Dip 1	Dip 2	Dip 3	Dip 4
Citroen	ON	OFF	OFF	OFF
Peugeot	OFF	OFF	OFF	OFF

After each change of the dip switch settings you have to execute a power reset of the CAN-box!

***Note:** No function of CAN-box in some vehicles, e.g. Maserati!

2. Installation

Switch off ignition and disconnect the vehicle's battery! The interface needs a permanent 12V source. If according to factory rules disconnecting the battery is to be avoided, it is usually sufficient to put the vehicle in sleep-mode. In case the sleep-mode does not show success, disconnect the battery with a resistor lead.

If power source is not taken directly from the battery, the connection has to be checked for being start-up proven and permanent.

2.1. Place of installation

The interface is installed at the **rear of head-unit**.

2.2. Connection schema

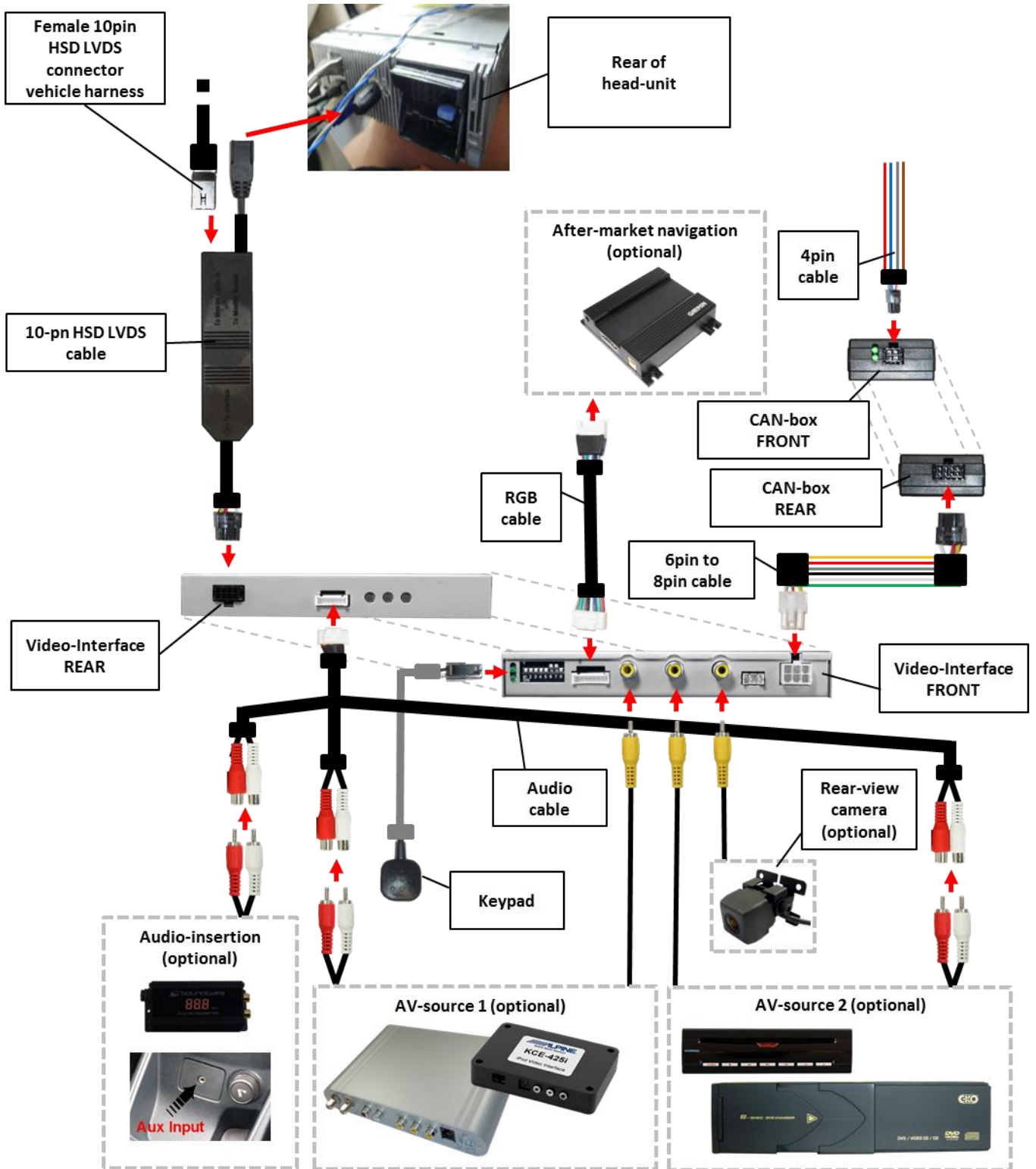

2.3. Connecting video-interface and CAN-box for Citroen and Peugeot vehicles

The CAN-bus box reads digital signals from the CAN-bus and converts them for the video-interface. ACC +12V max. 0.5A (red of 6pin) and reverse gear +12V max. 0.5A (green of 6pin) constant signal. Video-source switching (white of 6pin) as +12V impulse.

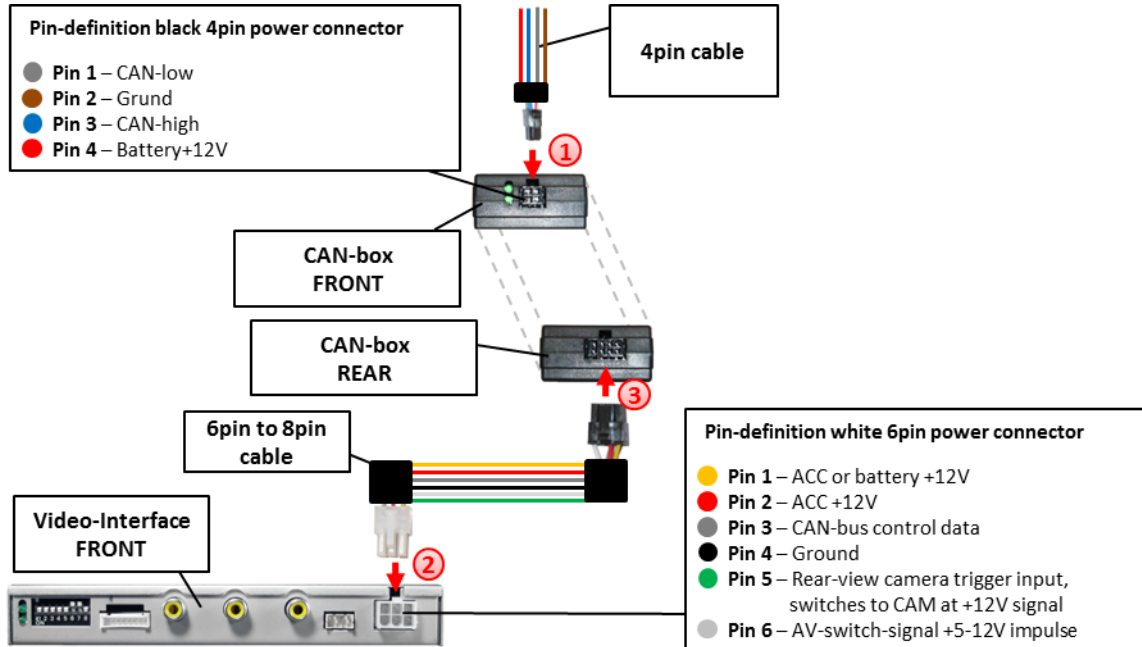

- 1 Connect black female 4pin Micro-Fit connector of the 4pin cable to the male 4pin Micro-Fit connector of the CAN-box.

Note: Check LEDs on CAN-box after reconnecting the battery, one must be on.

- 2 Connect white female 6pin Molex connector of the 6pin to 8pin cable to the male 6pin Molex connector of the video-interface.

- 3 Connect black female 8pin Micro-Fit connector of the 6pin to 8pin cable to male 8pin Micro-Fit connector of the CAN-box.

Note: Check LEDs on video-interface after reconnecting the battery, one must be on.

Pin-assignment vehicle connector

Cable colour	Assignment
Orange	+12Volt Permanent
Green	Ground
White	CAN HIGH
Grey	CAN LOW



No liability for vehicle wire colors and pin definition! Possible changes by the vehicle manufacturer. The given information must be verified by the installer.

2.4. Connecting video-interface for vehicles without function of CAN box

In some vehicles (e.g. Maserati), the CAN box has no function. In this case, omit the CAN box and use the 6-pin interface cable supplied with the open cable ends.

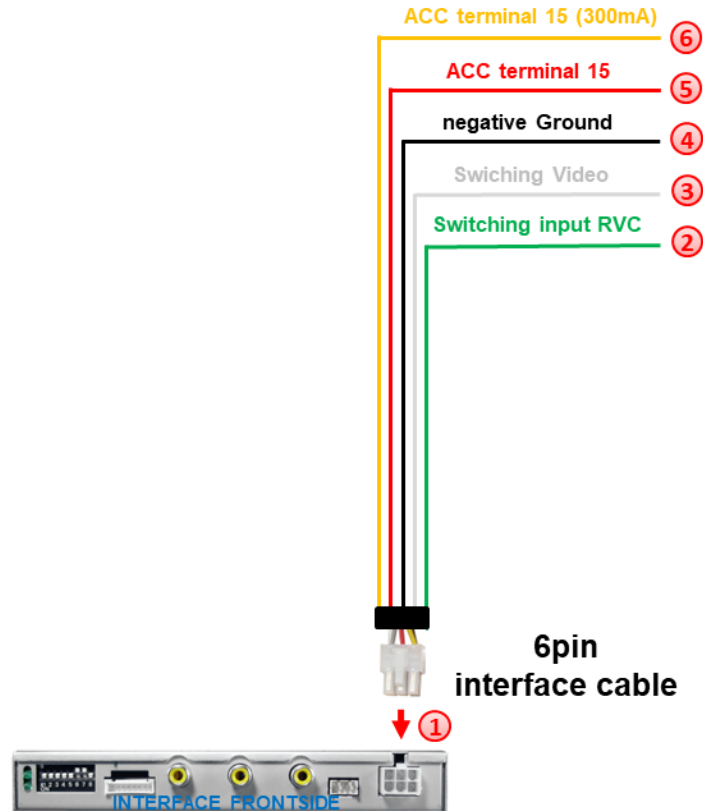

- ① Connect the white female 6pin connector of the 6pin interface cable to the male 6pin connector of the video interface.
- ② Connect the green wire of the 6pin interface cable to +12V of the reverse gear signal. (e.g. reversing light).
- ③ If desired, the white wire of the 6pin interface cable can be used alternatively to the external button to switch the video sources (12V pulse for 2-3 seconds).
- ④ Connect the black wire of the 6pin interface cable to vehicle ground.
- ⑤ Connect the red wire of the 6pin interface cable to +12V ACC terminal 15.
- ⑥ Connect the yellow wire of the 6pin interface cable to +12V ACC (300mA).

Note: The connection of the green wire (Reverse signal) will be described in chapter “After-market rear-view camera”. The white wire, can be used by +12V impulse to switch the enabled video sources , same as the keypad (see chapter “video interface-operation”).

2.5. Connections to the head-unit

Remove head-unit.

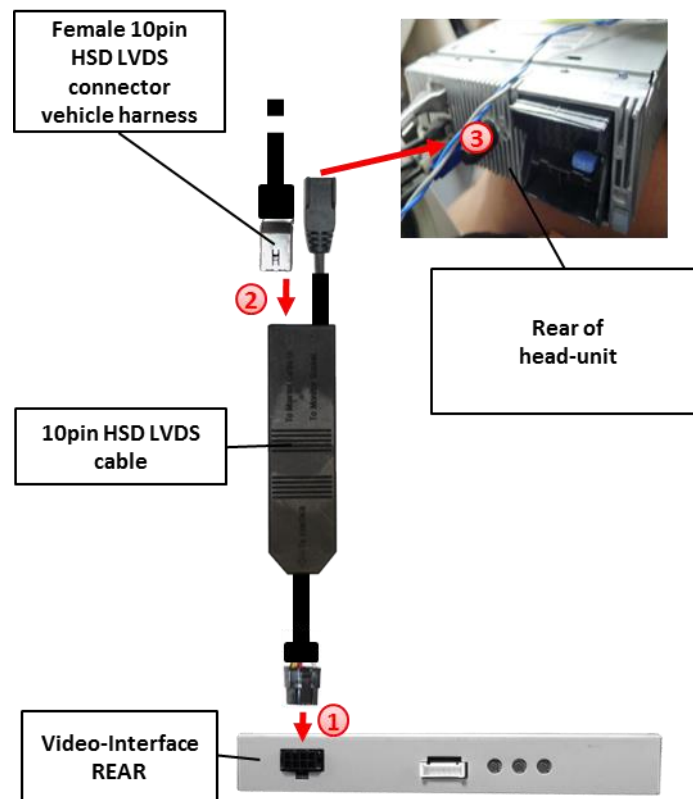

- ① Connect female 10pin Micro-Fit connector of the 10pin HSD LVDS cable to the male 10pin Micro-Fit connector of the video-interface.
- ② Remove female 10pin HSD LVDS connector from the rear of the head-unit and connect it to the LVDS-switch-box of the 10pin HSD LVDS cable.
- ③ Connect female 10pin connector of the 10pin HSD LVDS cable to the male 10pin HSD LVDS connector of the head-unit.

2.6. Connecting peripheral devices

It is possible to connect 2 after-market AV-sources and an after-market rear-view camera to the video-interface.

Before final installation of the peripheral devices, we recommend a test-run of the interface. Due to changes in the production of the vehicle manufacturer is always the possibility of incompatibility.

2.6.1. Video-sources to INJ1 and IN2

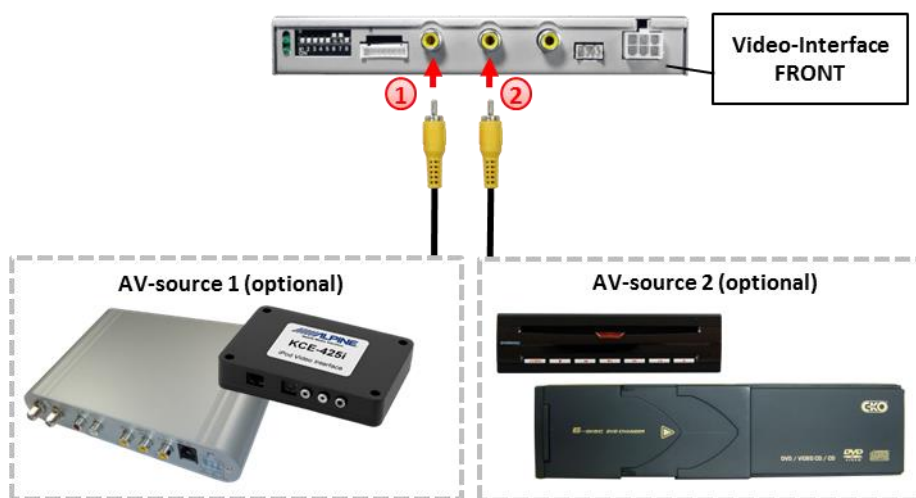

- 1 Connect video RCA of the AV-source 1 to the female RCA connector IN 1 of the video-interface.
- 2 Connect video RCA of the AV-source 2 to the female RCA connector IN 2 of the video-interface.

2.6.2. Audio-switch and audio insertion

This interface can only insert video signals into the factory infotainment and switch audio signals. If an AV-source is connected to AV1 or AV2, audio insertion must be done by factory audio AUX input or FM-modulator to which the interface's sound-switch output is connected. When the interface is switched from AV1 to AV2, the audio signal is switched parallel to the corresponding video signal by the interface's built-in audio-switch. The inserted video-signal can be activated simultaneously to each audio-mode of the factory infotainment.

Audio pins	Definition
1/2	Audio input signal R/L of source AV2
3/4	Audio input signal R/L of source AV1
5/6	Audio output signal R/L of factory audio AUX or FM-modulator
7	Ground

Note: If only one AV-source shall be connected, it is possible to connect the video output of the AV-source to the video input AV1 of the video-interface and the audio output of the AV-source directly to the point of audio-insertion (e.g. audio AUX input).

Pin-assignment white 12pin insert of the vehicle's Quadlock

Cable colour	Assignment
● Yellow	Audio left Pin 4
● Blue	Audio right Pin 3
● Brown	Ground Pin 5

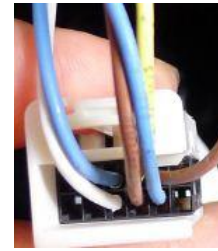

No liability for vehicle wire colors and pin definition! Possible changes by the vehicle manufacturer. The given information must be verified by the installer.

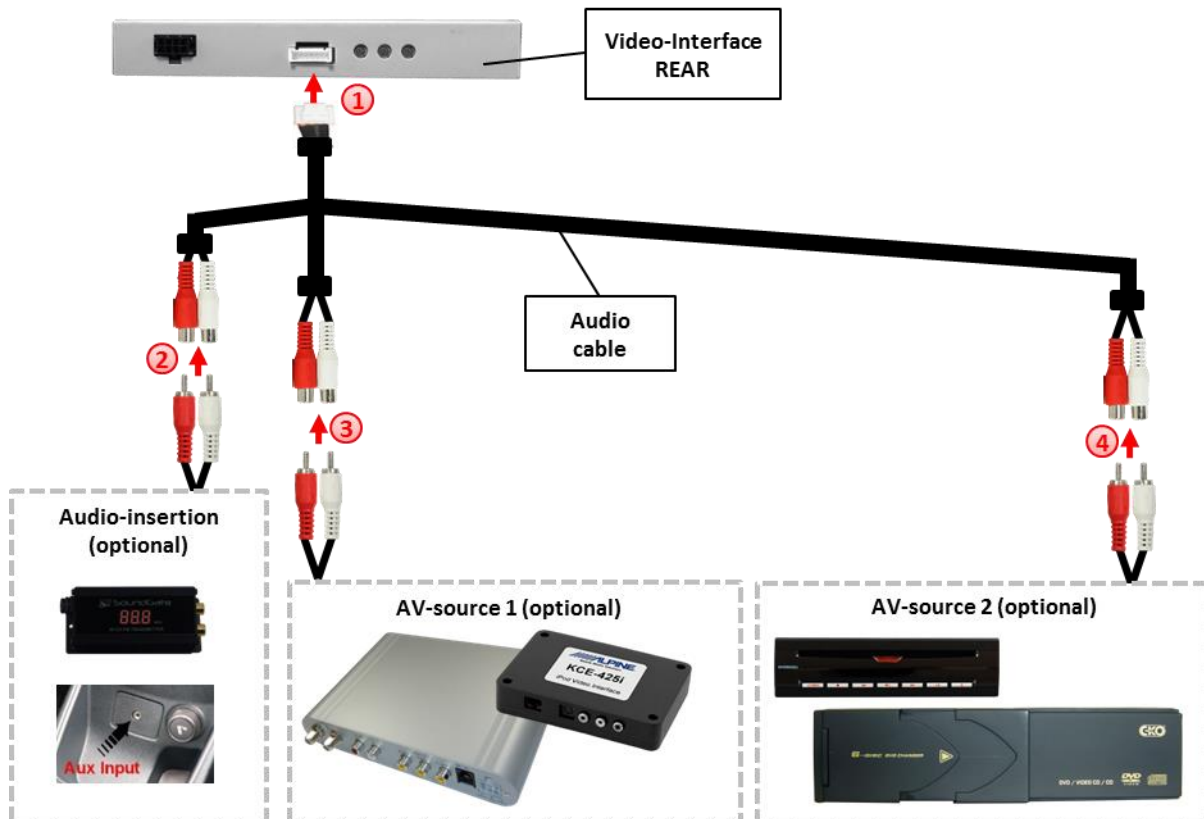

- ① Connect female 7pin connector of the audio cable to male 7pin connector of the video-interface.
- ② Connect the audio-RCA of the possibly existing factory AUX-input or the FM-modulator to the female RCA port AV-Out of the audio cable.
- ③ Connect the audio-RCA of the AV-source 1 to the female RCA port AV1 of the audio cable.
- ④ Connect the audio-RCA of the AV-source 2 to the female RCA port AV2 of the audio cable.

2.6.3. After-market rear-view camera

Some vehicles have a different reverse gear code on the CAN-bus which the included CAN-box is not compatible with. Therefore there is two different ways of installation. If the CAN-box can detect the reverse gear in the vehicle, the green wire of the 6pin to 8pin cable should carry +12V while the reverse gear is engaged.

Note: Do not forget to set dip5 of video-interface to ON before testing.

2.6.3.1. Case 1: CAN-box detects reverse gear

If the CAN-bus interface delivers +12V on the green wire of the 6pin to 8pin cable when reverse gear is engaged, the video interface will automatically be switched to the rear-view camera input CAM while reverse gear is engaged.

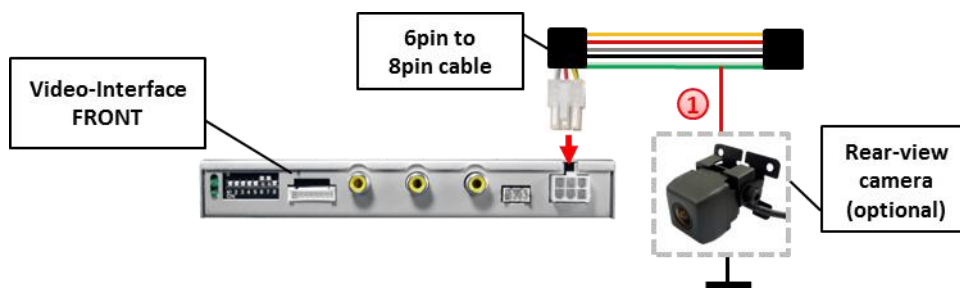

- 1 Additionally, the +12V (max. 500mA) power supply for the rear-view camera can be taken from the green wire of the 6pin to 8pin cable.

2.6.3.2. Case 2: CAN-box does not detect reverse gear

If the CAN-bus interface does not deliver +12V on the green wire of the 6pin to 8pin cable when reverse gear is engaged (not all vehicles are compatible) an external switching signal from the reverse gear light is required. As the reverse gear light signal contains electronic interference, a normally open relay (e.g AC-RW-1230 with wiring AC-RS5) or filter (e.g. AC-PNF-RVC) is required. Below schema shows the use of a relay (normally open).

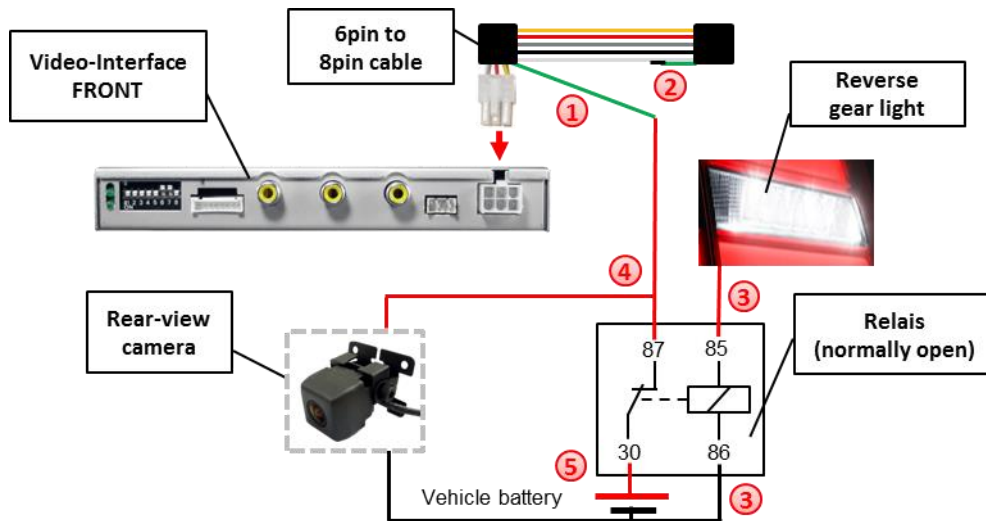

- ① Cut the green cable of the 6pin to 8pin cable close to the at the black 8pin connector.
- ② Isolate the short end of the green wire (CAN-box side).
- ③ Connect reverse gear light signal/power to coil (85) and ground to coil (86) of relais.
- ④ Connect rear-view camera power and green wire (video interface side) of 6pin to 8pin cable to output (87) of relay.
- ⑤ Connect permanent battery power to input (30) of relay.

2.6.3.3. Video signal connection

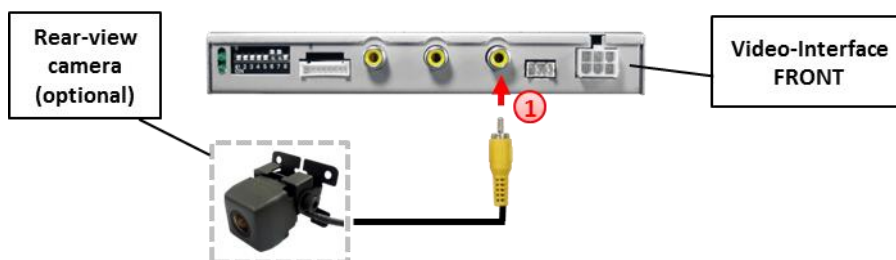

- 1 Connect the video-RCA of the after-market rear-view camera to the female RCA port of the video-interface which is labeled as CAM.

Note: Picture settings for CAM input must be done in AV2.

2.7. Connecting video-interface and keypad

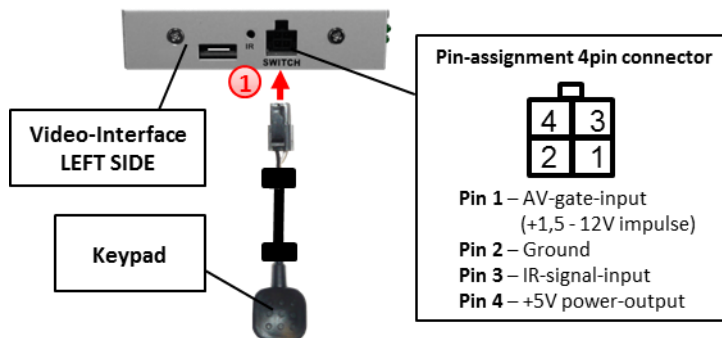

- 1 Connect the female 4pin connector of the keypad to the male 4pin connector of the video-interface.

2.7. Picture settings

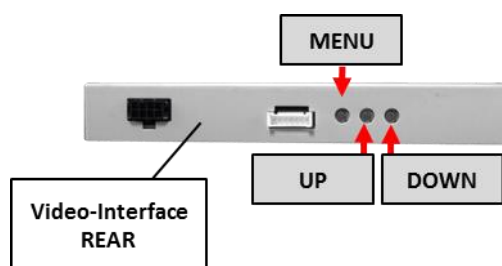

The picture settings are adjusted by the 3 buttons on the video-interface. Press the MENU button to open the OSD settings menu or to switch to the next menu item. Press UP and DOWN change the selected value. The buttons are embedded in the housing to avoid accidental changes during or after installation. Picture settings must be done separately for RGB, AV1 and AV2 while the corresponding input is selected and visible on the monitor. AV2 and CAM share the same settings which must be adjusted in AV2.

Note: The OSD menu is only shown when a working video source is connected to the selected video-input of the interface.

The following settings are available:

- Contrast
- Brightness
- Saturation
- Sharpness
- DVD – no function
- Tuner – no function
- Navi – no function

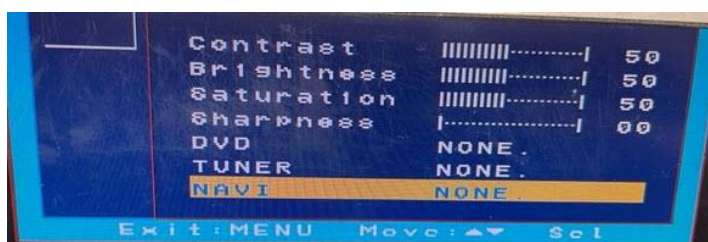

3. Interface operation

3.1. By factory-infotainment-buttons in vehicles with function of CAN box

Some of the factory-infotainment-buttons in Citroen and Peugeot vehicles can be used to execute interface functions.

Long press LIST-button (for Citroen vehicles)/ TRAF-button (for Peugeot vehicles) to switch the video source. Each repetition will switch to the next enabled input. If all inputs are enabled the order is:

Factory video → RGB-in → video IN1 → video IN2 → factory video →...

Inputs which are not enabled are skipped. If the audio cable is connected, when switching from video IN1 to video IN2, also the sound will be switched.

3.2. By keypad

Alternatively or additionally to the factory-infotainment-buttons the interface's keypad can be used to switch the enabled inputs. **Long press (2-3 seconds)** will switch the video source. Each repetition will switch to the next enabled input.

Note: The white wire of the 6pin cable can be used with a +12V pulse to switch the video-sources alternatively.

4. Specifications

BATT/ACC range	7V - 25V
Stand-by power drain	2mA
Power	140mA
Video input	0.7V - 1V
Video input formats	NTSC
RGB-video amplitude	0.7V with 75 Ohm impedance
Temperature range	-40°C to +85°C
Dimensions video-box	158 x 22 x 102 mm (W x H x D)
Dimensions CAN-box	73 x 22 x 45 mm (W x H x D)

5. FAQ – Trouble shooting Interface functions

For any troubles which may occur, check the following table for a solution before requesting support from your vendor.

Symptom	Reason	Possible solution
No picture/black picture (factory picture).	Not all connectors have been reconnected to factory head-unit or monitor after installation.	Connect missing connectors.
	No power on CAN-bus box (all LED CAN-bus box are off).	Check power supply of CAN-bus box. Check CAN-bus connection of CAN-bus box.
	CAN-bus box connected to CAN-bus in wrong place.	Refer to the manual where to connected to the CAN-bus. If not mentioned, try another place to connect to the CAN-bus.
	No power on video-interface (all LED video-interface are off).	Check whether CAN-bus box delivers +12V ACC on red wire output of 8pin to 6pin cable. If not cut wire and supply ACC +12V directly to video-interface.
No picture/black picture/white picture (inserted picture) but factory picture is OK.	No picture from video source.	Check on other monitor whether video source is OK.
	No video-source connected to the selected interface input.	Check settings dips 1 to 3 of video interface which inputs are activated and switch to corresponding input(s).
	LVDS cables plugged in wrong place.	Double-check whether order of LVDS cables is exactly connected according to manual. Plugging into head-unit does not work when the manual says to plug into monitor and vice versa.
Inserted picture totally wrong size or position.	Wrong monitor settings of video-interface.	Try different combinations of dips 7 and 8 of video-interface. Unplug 6pin power after each change.
Inserted picture double or 4 times on monitor.		
Inserted picture distorted, flickering or running vertically.	Video sources output set to AUTO or MULTI which causes a conflict with the interfaces auto detection.	Set video source output fixed to PAL or NTSC. It is best to set all video sources to the same standard.
	If error occurs only after source switching: Connected sources are not set to the same TV standard.	Set all video sources to the same standard.
	Some interfaces can only handle NTSC input.	Check manual whether there is a limitation to NTSC mentioned. If yes, set source fixed to NTSC output.
Inserted picture b/w.	Picture settings have not been adjusted.	Use the 3 buttons and the interface's OSD to adjust the picture settings for the corresponding video input.
Inserted picture qual. bad.		
Inserted picture size slightly wrong.		
Inserted picture position wrong.		
Camera input picture flickers.	Camera is being tested under fluorescent light which shines directly into the camera.	Test camera under natural light outside the garage.
Camera input picture is bluish.	Protection sticker not removed from camera lens.	Remove protection sticker from lens.

Symptom	Reason	Possible solution
Camera input picture black.	Camera power taken directly from reverse gear lamp.	Use relay or electronics to "clean" reverse gear lamp power. Alternatively, if CAN-bus box is compatible with the vehicle, camera power can be taken from green wire of 6pin to 8pin cable.
Camera input picture has distortion.		
Camera input picture settings cannot be adjusted.	Camera input picture settings can only be adjusted in AV2 mode.	Set dip 3 of video-interface to ON (if not input AV2 is not already activated) and connect the camera to AV2. Switch to AV2 and adjust settings. Reconnect camera to camera input and deactivate AV2 if not used for other source.
Graphics of a car in camera input picture.	Function PDC is ON in the interface OSD.	In compatible vehicles, the graphics will display the factory PDC distance. If not working or not wanted, set interface OSD menu item UI-CNTRL to ALLOFF.
Chinese signs in camera input picture	Function RET or ALL is ON (function for Asian market) in the interface OSD.	Set interface OSD menu item UI-CNTRL to ALLOFF or PDCON.
Not possible to switch video sources by OEM button.	CAN-bus interface does not support this function for vehicle.	Use external keypad or cut white wire of 6pin to 8pin cable and apply +12V impulses for AV-switching.
Not possible to switch video sources by external keypad.	Pressed too short.	For video source switching a longer press of about 2.5 seconds is required.
	SW-version of interface does not support external keypad.	Use OEM-button or cut white wire of 6pin to 8pin cable and apply +12V impulses for AV-switching.
Interface does not switch to camera input when reverse gear is engaged.	CAN-bus interface does not support this function for the vehicles.	Cut the green wire of the 6pin to 8pin cable and apply +12V constant from reverse gear-lamp signal. Use relay to "clean" R-gear lamp power.
Interface switches video-sources by itself.	CAN-bus interface compatibility to vehicle is limited.	Cut the grey wire of 6pin to 8pin and isolate both ends. If problem still occurs, additionally cut the white wire of 6pin to 8pin cable and isolate both ends.

6. Technical Support

Please note that direct technical support is only available for products purchased directly from NavLinkz GmbH. For products bought from other sources, contact your vendor for technical support.

NavLinkz GmbH
distribution/tech dealer-support
 Heidberghof 2
 D-47495 Rheinberg

Tel +49 2843 17595 00
 Email mail@navlinkz.de

 10R-03 5384

Made in China

