

Video-inserter

VL2-SY2-N

**Compatible with Ford vehicles with
Sync2 System
with 8" touch monitor**



Video-inserter with 2 video + rear-view camera input and CAN control

Product features

- Video-inserter for factory-navigation systems
- 2 video-inputs for after-market devices (e.g. DVD-Player, DVB-T tuner, ...)
- Built-in audio-switch (no audio-insertion)
- Rear-view camera video-input
- Automatic switching to rear-view camera input on engagement of the reverse gear
- Activatable parking guidelines for rear-view camera (not available for all vehicles)
- Video-in-motion (ONLY for connected video-sources)
- Video-inputs NTSC compatible

Contents

1. Prior to installation

- 1.1. Delivery contents
- 1.2. Checking the compatibility of vehicle and accessories
- 1.3. Boxes and connectors
 - 1.3.1. Video-Interface
 - 1.3.2. CAN-bus box
 - 1.3.2.1. Dip-switch settings
 - 1.3.2.2. Enabling the interface's video inputs (dip 2-3)
 - 1.3.2.3. Rear-view camera setting (dip 5)
 - 1.4. Dip-switch settings of the CAN-box

2. Installation

- 2.1. Place of installation
 - 2.1.1. Place of Installation – Interface
 - 2.1.2. Place of Installation – daughter PCB
- 2.2. Connection schema
- 2.3. Connecting video-interface and CAN-box
- 2.4. Connection to the vehicle's head unit
- 2.5. Connection to the vehicle's monitor
 - 2.5.1. Warning notes, concerning the installation of ribbon cables
- 2.6. Connecting of peripheral devices
 - 2.6.1. Video-sources to AV1 and AV2
 - 2.6.2. Audio-switch and audio-insertion
 - 2.6.3. After-market rear-view camera
 - 2.6.3.1. Case 1: CAN-box receives the reverse gear signal
 - 2.6.3.2. Case 2: CAN-box does not receive the reverse gear signal
 - 2.6.3.3. Connection Video signal
- 2.7. Connecting video-interface and keypad
- 2.8. Picture settings and guidelines

3. Interface operation

- 3.1. By Voice button
- 3.2. By keypad

4. Specifications

5. FAQ – Trouble Shooting-Interface functions

6. Technical support

Legal Information

By law, watching moving pictures while driving is prohibited, the driver must not be distracted. We do not accept any liability for material damage or personal injury resulting, directly or indirectly, from installation or operation of this product. Apart from using this product in an unmoved vehicle, it should only be used to display fixed menus or rear-view-camera video when the vehicle is moving (for example the MP3 menu for DVD upgrades).

Changes/updates of the vehicle's software can cause malfunctions of the interface. Up to one year after purchase we offer free software-updates for our interfaces. To receive a free update, the interface has to be sent in at own cost. Wages for de-and reinstallation and other expenditures involved with the software-updates will not be refunded.

1. Prior to installation

Read the manual prior to installation. Technical knowledge is necessary for installation. The place of installation must be free of moisture and away from heat sources.

1.1. Delivery contents

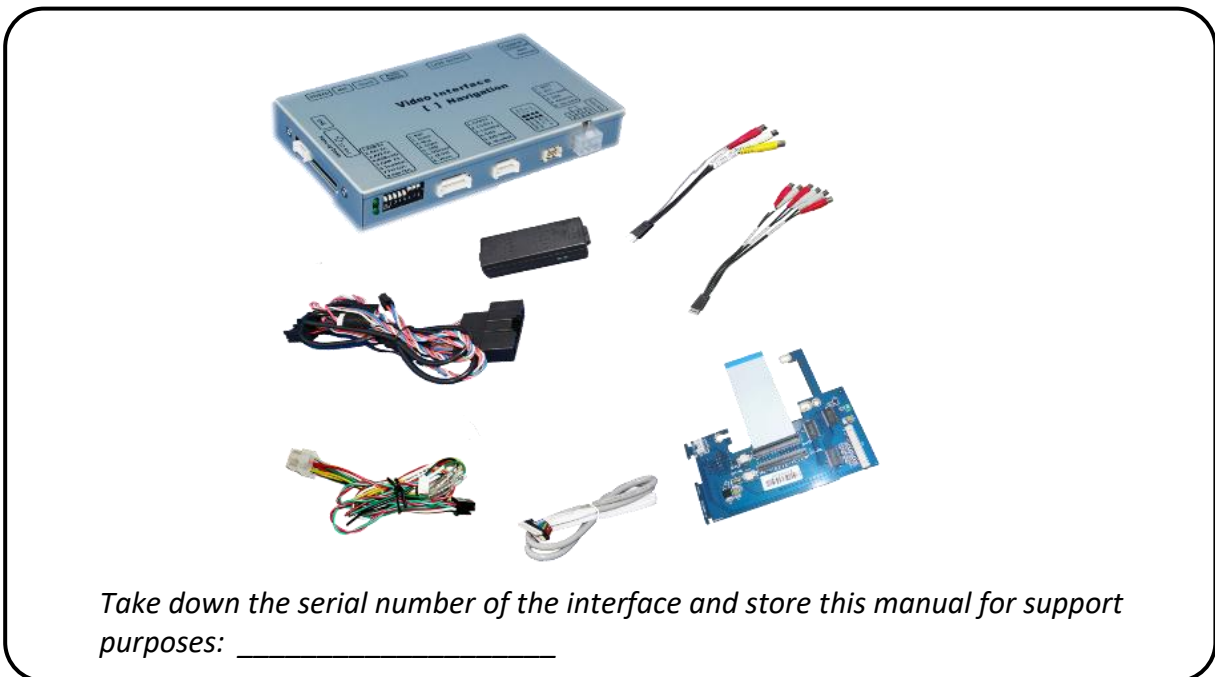

1.2. Checking the compatibility of vehicle and accessories

Requirements		
Brand	Compatible vehicle models	Infotainment
Ford	C-Max model year 2016-2017, Focus model year 2015-2016, Galaxy model year until 2016, Kuga2 about 2015 until 09/2016, Mondeo model year 2015-2016/2017, Ranger model year 2015-2016, Raptor F150 model year 2013, S-Max model year bis 2015, and other vehicles with	Sony Sync2 Touch
Limitations		
<i>Video only</i>	The interface inserts ONLY video signals into the infotainment. For inserting Audio signals either the possibly existing factory audio-AUX-input or a FM-modulator can be used.	
<i>Factory rear-view camera</i>	Automatically switching-back from inserted video to factory rear-view camera is only possible while the reverse gear is engaged. To delay the switch-back, an additional electronic part is required.	
<i>Guidelines</i>	Displayed guidelines are not available in all vehicles.	
<i>Video input signal</i>	Only NTSC video sources are compatible.	

1.3. Boxes and connectors

1.3.1. Video Interface

The video-interface converts the connected after-market sources video signals into a LVDS signal which is inserted in the factory monitor using separate trigger options.

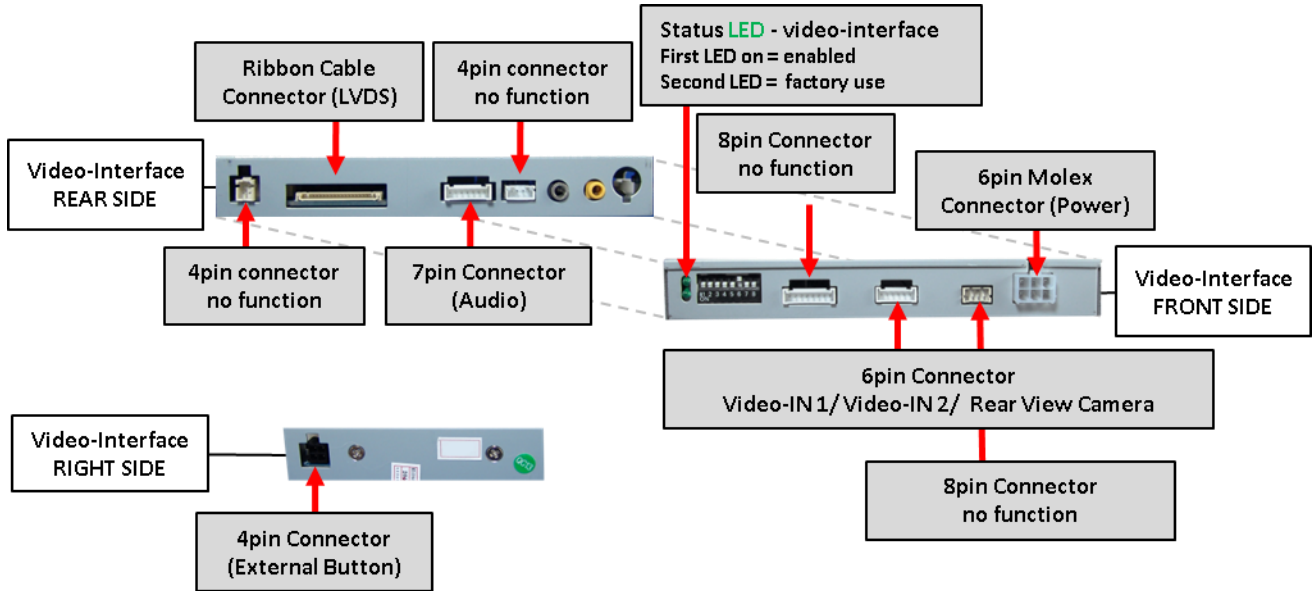

1.3.2. CAN-bus box

The CAN box reads the vehicle's digital signals out of the vehicle's CAN-bus and converts them for the video interface.

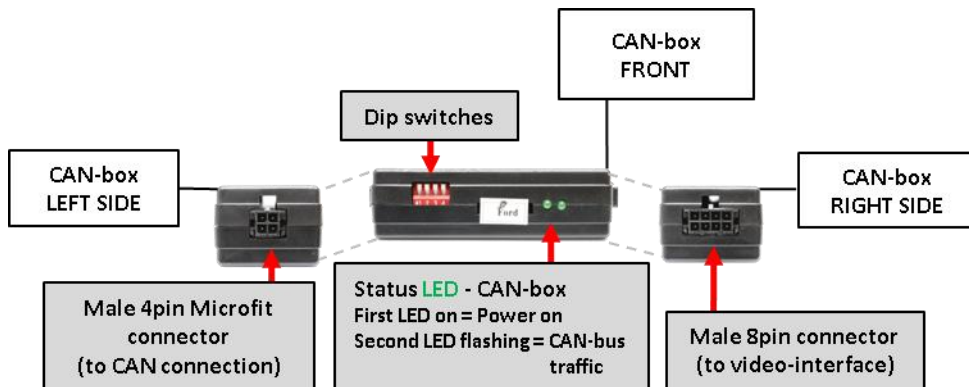

1.3.2.1. Dip-switch settings

Some settings have to be selected by the dip-switches on the video interface. Dip position down is ON and position up is OFF.

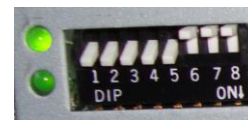

Dip	Function	ON (down)	OFF (up)
1	No function		Set to OFF
2	CVBS AV1-input	enabled	disabled
3	CVBS AV2-input	enabled	disabled
4	No function		Set to OFF
5	Rear-view cam type	after-market	factory or none
6	No function	-	Set to OFF
7	No function		Set to OFF
8			

See the following chapters for detailed information.

1.3.2.2. Enabling the interface's video inputs (dip 2-3)

Only the enabled video inputs can be accessed by switching through the interface's video sources. It is recommended to enable only the required inputs, because the disabled inputs will be skipped while switching through the video interfaces inputs.

1.3.2.3. Rear-view camera setting (dip 5)

If set to OFF, the interface switches to factory LVDS picture while the reverse gear is engaged to display factory rear-view camera or factory optical park system picture.

If set to ON, the interface switches to its rear-view camera input while the reverse gear is engaged.

1.4. Dip-switch settings of the CAN-box

By using red coloured **4 dip-switches** the CAN-Bus communication between the appropriate factory head-unit and the interface will be associated to the type of vehicle, in which the interface will be connected to.

Dip switch 1-4 have to be set to "OFF".

Dip position down is ON and position up is OFF.



After each Dip-switch-change a power-reset of the Can-box has to be performed!

2. Installation

To install the interface, first switch off the ignition and disconnect the vehicle's battery. Please read the owner's manual of the car, regarding the battery's disconnection! If required, enable the car's Sleep-mode (hibernation mode)

In case the sleep-mode does not succeed, the disconnection of the battery can be done with a resistor lead.

If the necessary stabilized power supply for the interface is not taken directly from the battery, the chosen connection has to be checked for being constantly stable.

The interface needs a permanent 12V source!

2.1. Place of installation

2.1.1. Place of installation for the interface-box

The interface is built to be connected behind the vehicle's monitor and head-unit.

2.1.2. Place of installation for the daughter PCB

The interface's daughter PCB is built to be installed in the monitor housing.

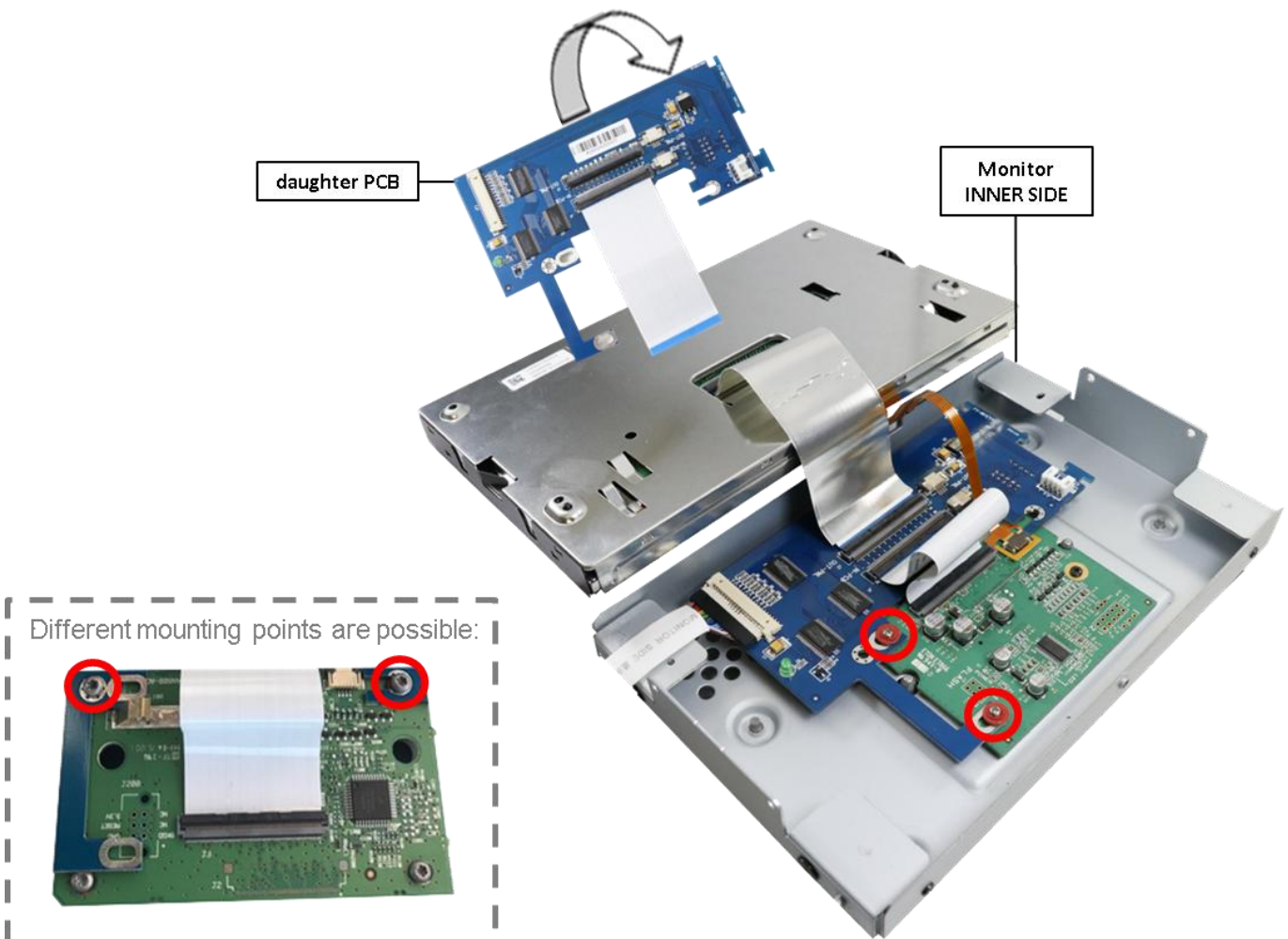

2.2. Connection schema

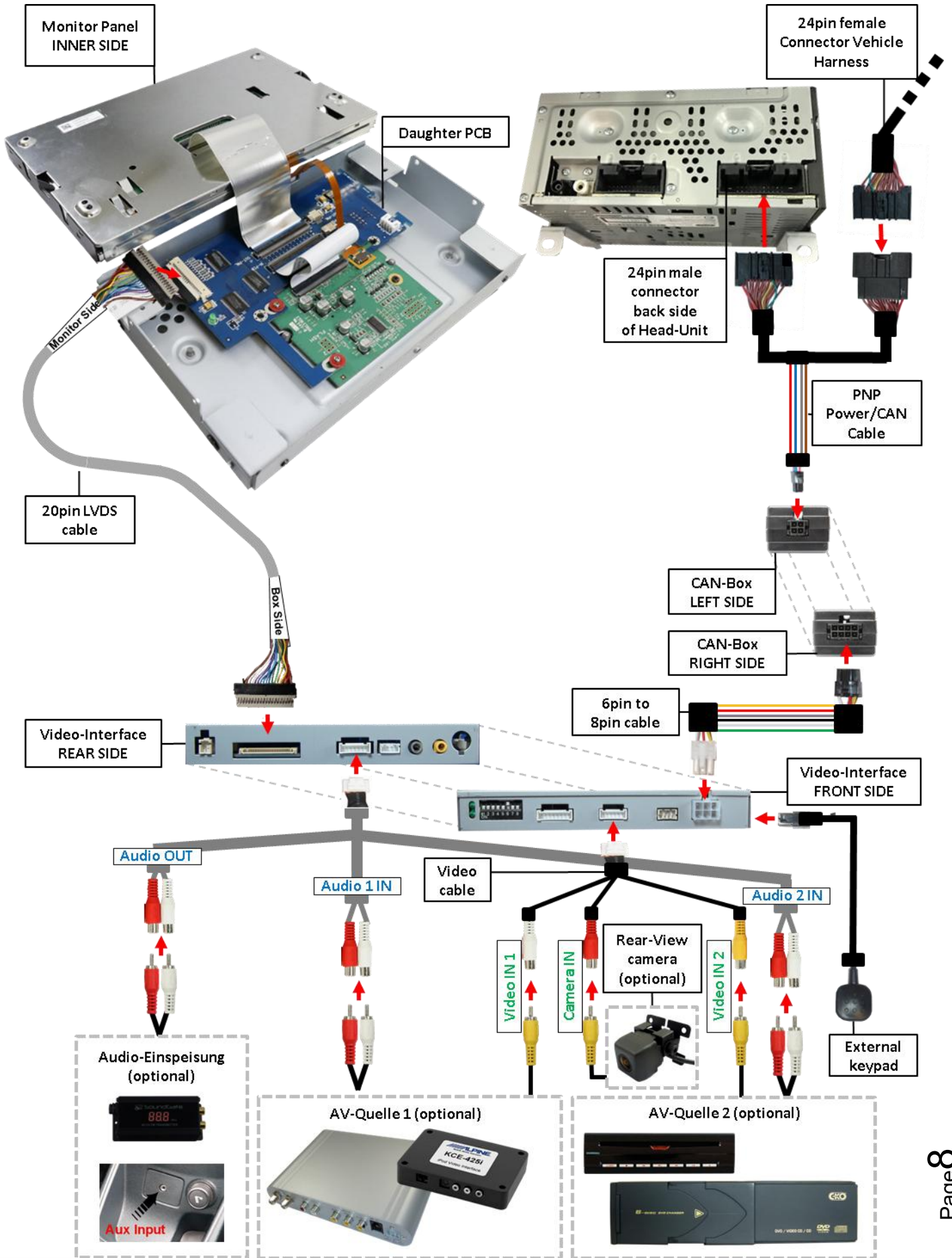

2.3. Connecting video-interface and CAN-box

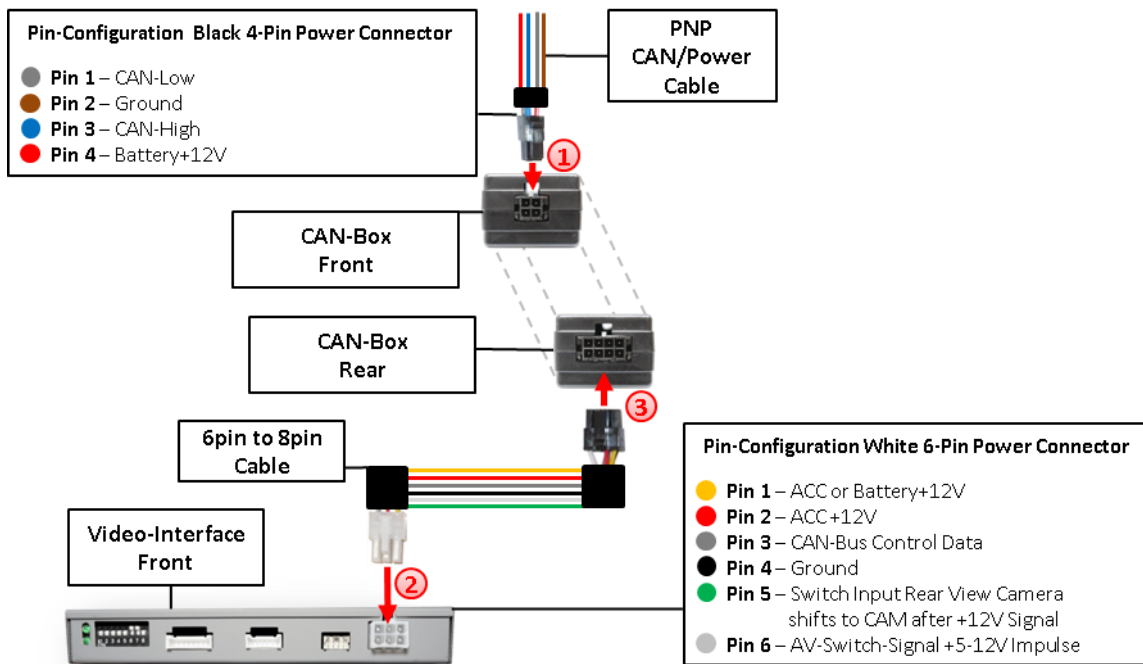

- ① Connect the black female 8pin Micro-Fit connector of the PNP Power/CAN harness to the male 8pin Micro-Fit connector of the CAN-box.

Note: Check the LEDs on CAN-box after reconnecting the battery, two must be on.

- ② Connect the white female 6pin Molex connector of the 6pin to 8pin cable to the male 6pin Molex connector of the video-interface.

- ③ Connect the black female 8pin Micro-Fit connector of the 6pin to 8pin cable to male 8pin Micro-Fit connector of the CAN-box.

Note: Check the LEDs on the video-interface after reconnecting the battery, one must be on.

Note: No liability for vehicle wire colours and pin definition!

Changes by the vehicle manufacturer are possible. The given information has to be verified by the installer.

2.4. Connection to the vehicle's head-unit

Remove the vehicle's head-unit.

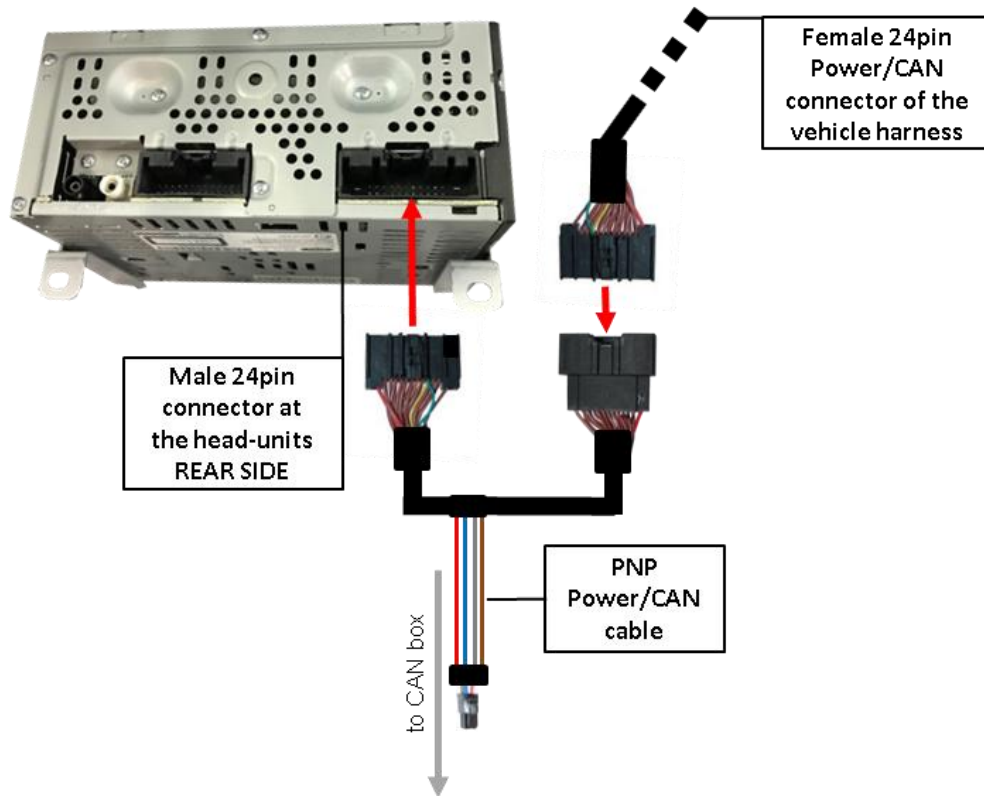

- ① Disconnect the female 24pin connector of the vehicle harness from the vehicle's head-unit and connect it to the male 24pin connector of the PNP Power/CAN cable
- ② Connect the female 24pin connector of the PNP Power/CAN cable to the male 24pin connector of the vehicle's head-unit.

2.5. Connection to the vehicle's monitor

Remove the vehicle's monitor and turn off the 12 OEM screws of the monitor's frame for folding up the monitor panel from its housing. Do not loosen the 3 bigger screws on the monitor's rear side!

- ① Pull out the brown colored 4pin touch ribbon cable from the original PCB. The disconnecting is only necessary for the easy installation procedure! After the installation of the daughter PCB is done, it has to be reconnected at the same place!
- ② Remove the 60pin ribbon cable from the original PCB by unclipping the Ribbon cable base and connect it to the daughter PCB's 60pin ribbon cable base "OUT PNL". Make sure that the connector pins of each pin connector are faced to the platinum before clipping them.
- ③ Connect the daughter PCB's 60pin ribbon cable to the free 60pin ribbon cable base at the original PCB (take care again for a platinum faced installation of the connector pins!).
- ④ Turn off the 2 screws of the original PCB and fix the daughter PCB onto it, by using the enclosed screws and washers (different mounting points are possible –refer to chapter "Place of installation for the daughter PCB"). The long holes of the daughter PCB will permit a straight mounting and the perfect connection of the ribbon cables
- ⑤ Connect the beige colored male 20pin connector (**Monitor Side**) of the 20pin cable to the female 20pin connector of the daughter PCB and connect the second beige colored male 20pin connector (**Box Side**) opposite the cable to the female 20pin connector of the video interface. Take care for installing the cable in the right direction as both connectors are identical. (Pay attention to the wire's caption "**MONITOR SIDE**" and "**BOX SIDE**")

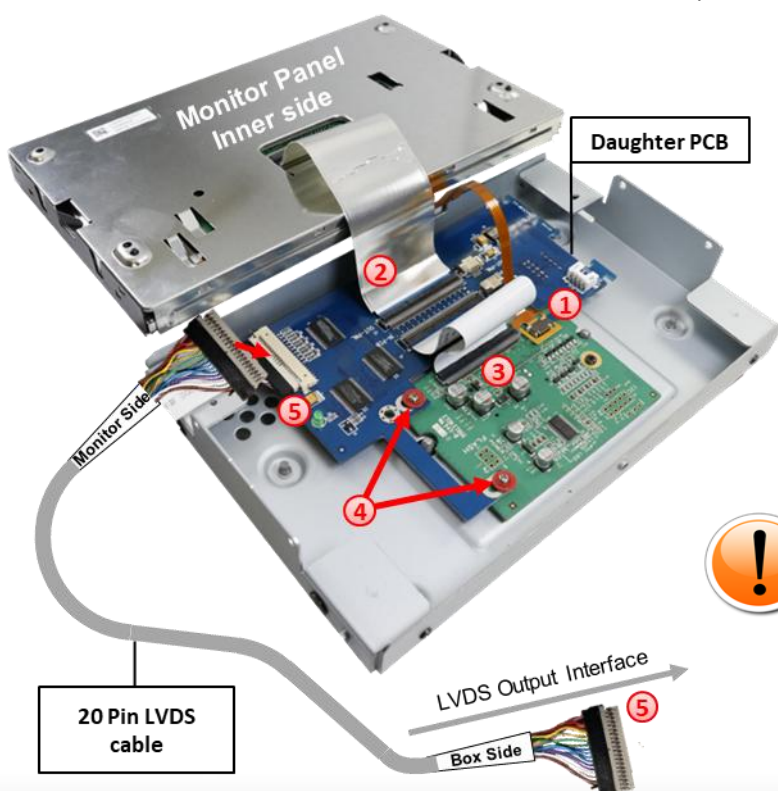

If there is a housing screw at the position marked above during reassembly, it must not reach into the interior of the housing, otherwise, as shown in the picture, the LVDS connector may be damaged when screwed in!

2.5.1. Warning notes, concerning the installation of ribbon cables:

- 1) The contacting ends of ribbon cables always have to be installed in a straight and precise 180° position to the connector. Each deviation from a perfect contact position will cause faulty contact and even danger of short circuit
- 2) The ribbon cable's contacting side always has to correspond to the contacting side of the connector, concerning the mounting position.

2.6. Connecting peripheral devices

It is possible to connect one after-market RGB navigation (or another RGB video source), two after-market AV-sources and one after-market rear-view camera to the video-interface.

Before final installation of the peripheral devices, we recommend a test-run to detect a incompatibility of vehicle and interface. Due to changes in the production of the vehicle manufacturer there's always a possibility of incompatibility.

2.6.1. Video-sources to AV1 and AV2

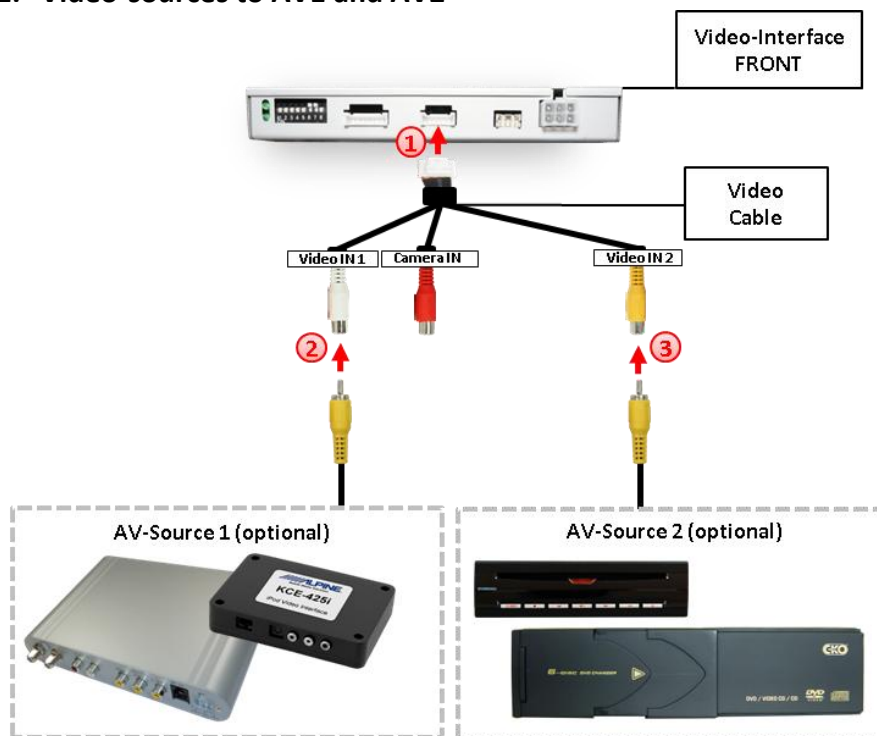

① Connect the video cable's female 6pin connector to the video interface's male 6pin connector .

②

Connect of the AV-source 1's video RCA to the video cable's female RCA connector Video IN 1.

- 3 Connect the AV-source 2's video RCA to the video cable's female RCA connector Video IN2.

2.6.2. Audio-switch and audio-insertion

This interface is only able to insert video signals into the factory infotainment and switch audio signals. If an AV-source is connected to AV1 or AV2, audio insertion must be done by factory audio AUX input or FM-modulator to which the interface's sound-switch output is connected. When the interface is switched from AV1 to AV2, the audio signal is switched parallel to the corresponding video signal by the interface's built-in audio-switch. The inserted video-signal can be activated simultaneously to each audio-mode of the factory infotainment.

Audio pins	Definition
1/2	Audio input signal R/L of source AV2
3/4	Audio input signal R/L of source AV1
5/6	Audio output signal R/L of factory audio AUX or FM-modulator
7	Ground

Note: If only one AV-source shall be connected, it is possible to connect the audio output of the AV-source directly to the point of audio-insertion (e.g. audio AUX input).

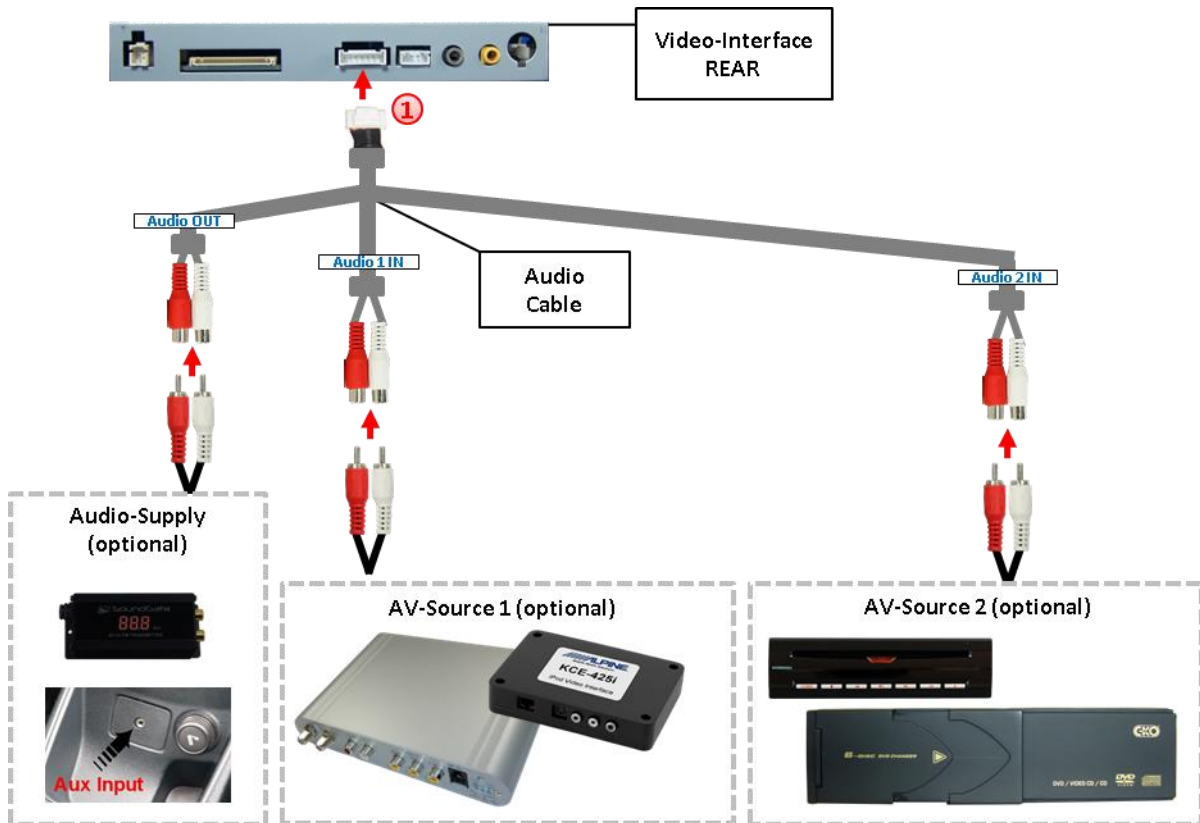

- ① Connect the female 7pin connector of the audio cable to male 7pin connector of the video-interface.
- ② Connect the audio-RCA of the possibly existing factory AUX-input or the FM-modulator to the female RCA port AV-Out of the audio cable.
- ③ Connect the audio-RCA of the AV-source 1 to the female RCA port AV1 of the audio cable.
- ④ Connect the audio-RCA of the AV-source 2 to the female RCA port AV2 of the audio cable.

2.6.3. After-market rear-view camera

Some vehicles have a different reverse gear code on the CAN-bus which the included CAN-box is not compatible with. In this case there are two different ways of installation. If the CAN-box is able to detect an enabled vehicle's reverse gear, the green wire of the 6pin to 12pin cable should carry +12V while the reverse gear is engaged.

Note: Do not forget to set dip5 of video-interface to ON before testing.

2.6.3.1. Case 1: CAN-box receives the reverse gear signal

If the CAN-bus box delivers +12V on the green wire of the 6pin to 12pin cable while reverse gear is engaged, the video interface will automatically switch to the rear-view camera input CAM while the reverse gear is engaged.

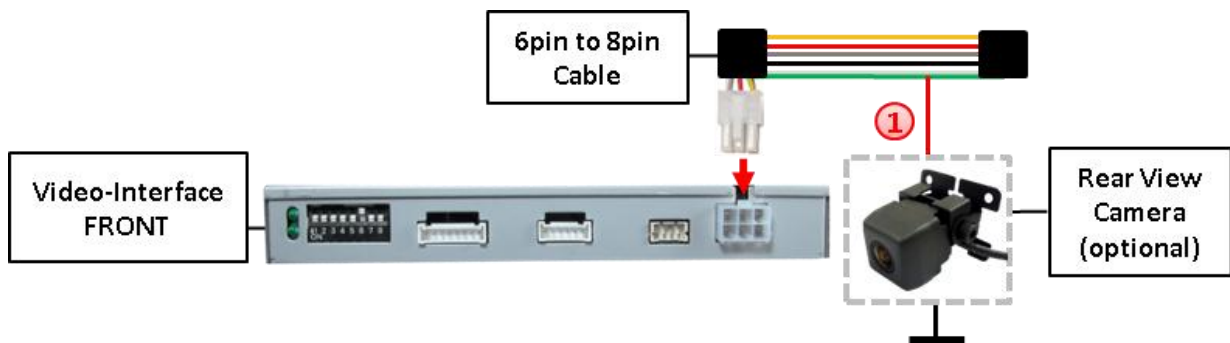

- 1 Additionally, the +12V (max. 500mA) power supply for the rear-view camera can be taken from the green wire of the 6pin to 12pin cable.

2.6.3.2. Case 2: CAN-box does not receive the reverse gear signal

If the CAN-bus interface does not deliver +12V on the green wire of the 6pin to 12pin cable when reverse gear is engaged (not all vehicles are compatible) an external switching signal from the reverse gear light is required. As the reverse gear light signal contains electronic interference, a traditional open relay (e.g AC-RW-1230 with wiring AC-RS5) or filter (e.g. AC-PNF-RVC) is required. Below schema shows the use of a relay (normally open).

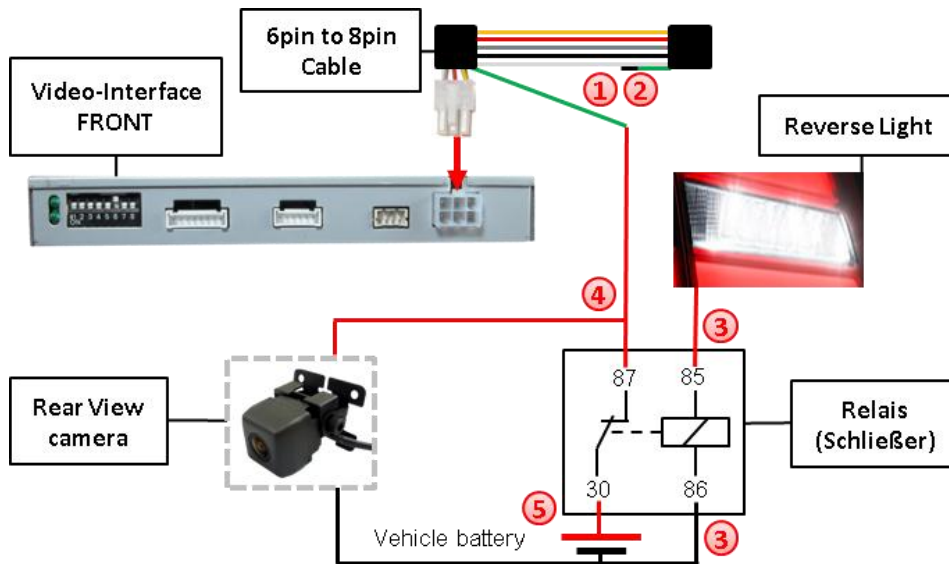

- ① Cut the green cable of the 6pin to 8pin cable close to the black 12pin connector.
- ② Isolate the short end of the green wire (CAN-box side).
- ③ Connect the reverse gear light signal/power to coil (85) and ground to coil (86) of relay.
- ④ Connect the rear-view camera power wire and the green wire (video interface side) of 6pin to 8pin cable both to output (87) of the relay.
- ⑤ Connect permanent battery power to input (30) of relay.

2.6.3.3. Video signal connection

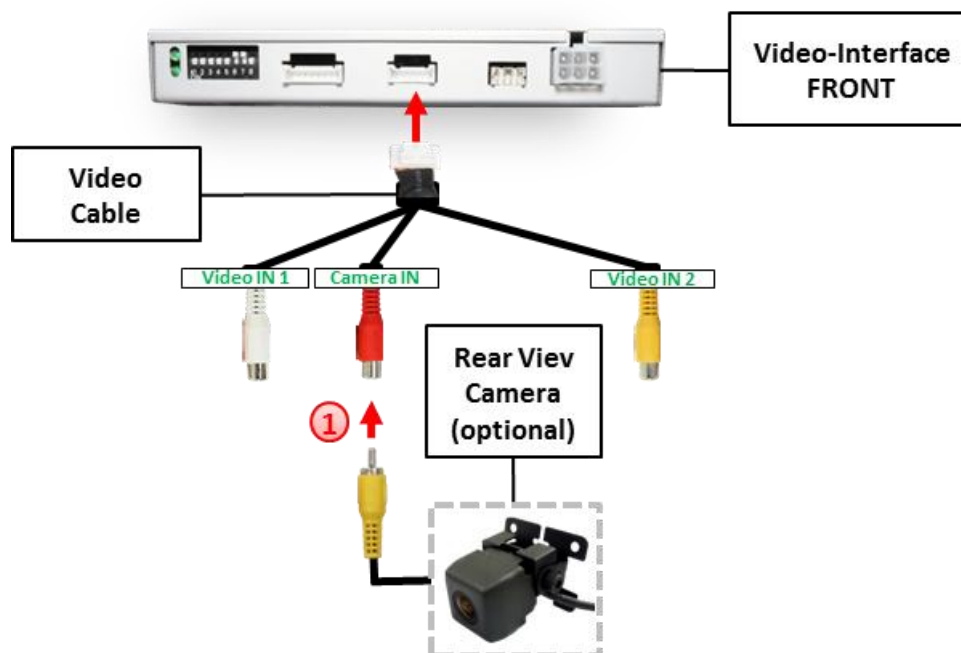

- 1 Connect the video-RCA of the after-market rear-view camera to the female RCA port of the video-interface which is labeled as CAM.

Note: The picture settings for CAM input have to be adjusted in AV2.

2.7. Connecting video-interface and keypad

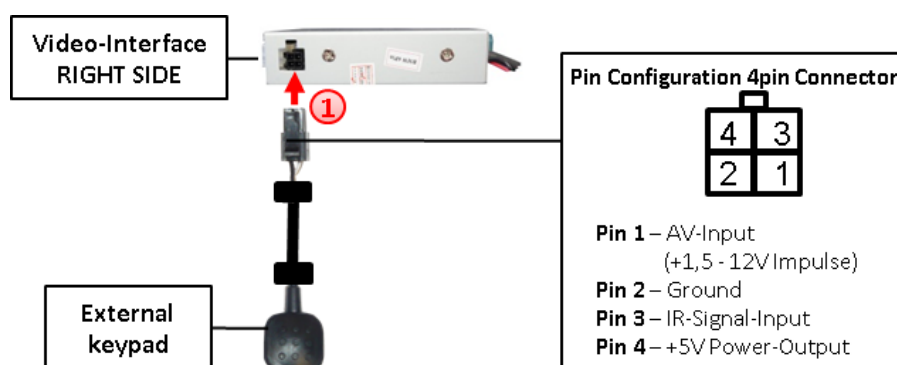

- 1 Connect the female 4pin connector of the keypad to the male 4pin connector of the video-interface.

2.8. Picture settings and guide lines

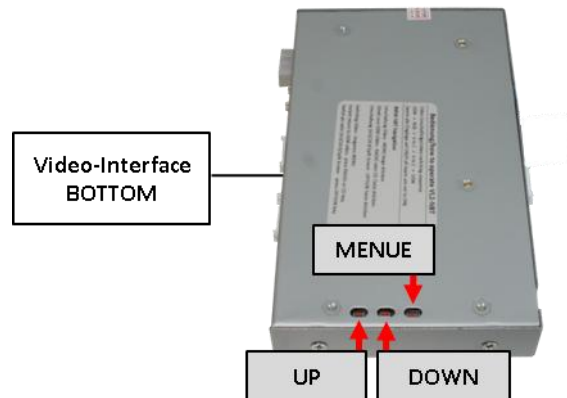

The picture settings are adjustable by the 3 push-buttons on the video-interface. Press the MENU button to open the OSD settings menu or to switch to the next menu item. Press UP and DOWN to change the selected value. The buttons are placed inside in the housing to avoid accidental changes during or after the installation. Picture settings must be done separately for RGB, AV1 and AV2 while the corresponding input is selected and visible on the monitor. **AV2 and CAM share the same settings which must be adjusted in AV2.**

Note: The OSD menu is only shown when a working video source is connected to the selected video-input of the interface.

The following settings are available:

- Contrast
- Brightness
- Saturation
- Position H (horizontal)
- Position V (vertical)
- IR-AV1/2 (no function)
- Guide L/R (no function)
- UI-CNTRL (guide lines ON/OFF)
- Size H/V (picture size horizontal/vertical)

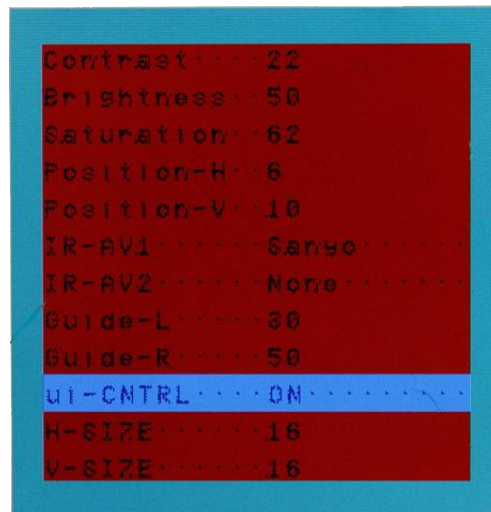

Note: If there is no communication between the CAN box and the vehicle`s CAN-bus (several vehicles aren`t compatible), the .reverse gear guide-lines can`t be shown during the vehicle`s operation, even if they once appear after having switched the system to powerless!

3. Interface operation

3.1. By Voice button

To switch the Video sources the vehicle's **Voice button** can be used (pay attention to dip4 in the CAN box, refer chapter "Dip-switch settings of the CAN-box").

Each press will switch to the next enabled input. If all inputs are enabled the order is:

Factory video → *video IN1* → *video IN2* → *factory video* →...

Disabled inputs will be skipped. While switching from video in-1 to video in-2 the Audio-source will be switched too, assuming the sources have also been connected to the audio cable

Switchover by vehicle buttons isn't possible in all vehicles. In some vehicles the external keypad has to be used.

Note: The white wire of the 6pin cable can be used with a +5-12V pulse to switch the video-sources alternatively.

3.2. By keypad

Alternatively or additionally to the factory infotainment button, the interface's external keypad can be used to switch the enabled inputs.

4. Specifications

BATT/ACC range	7V - 25V
Stand-by power drain	<10mA
Power	0.7A @12V
Video input	0.7V - 1V
Video input formats	NTSC
RGB-video amplitude	0.7V with 75 Ohm impedance
Temperature range	-40°C to +85°C
Dimensions video-box	155 x 22 x 90 mm (W x H x D)
Dimensions CAN-box	73 x 22 x 30 mm (W x H x D)



5. FAQ – Trouble shooting Interface functions

For any troubles which may occur, check the following table for a solution before requesting support from your vendor.

Symptom	Reason	Possible solution
No picture/black picture (factory picture).	Not all connectors have been reconnected to factory head-unit or monitor after installation.	Connect missing connectors.
	No power on CAN-bus box (all LED CAN-bus box are off).	Check power supply of CAN-bus box. Check CAN-bus connection of CAN-bus box.
	CAN-bus box connected to CAN-bus in wrong place.	Refer to the manual where to connected to the CAN-bus. If not mentioned, try another place to connect to the CAN-bus.
	No power on video-interface (all LED video-interface are off).	Check whether CAN-bus box delivers +12V ACC on red wire output of 8pin to 6pin cable. If not cut wire and supply ACC +12V directly to video-interface.
No picture/black picture/white picture (inserted picture) but factory picture is OK.	No picture from video source.	Check on other monitor whether video source is OK.
	No video-source connected to the selected interface input.	Check settings dips 1 to 3 of video interface which inputs are activated and switch to corresponding input(s).
	LVDS cables plugged in wrong place.	Double-check whether order of LVDS cables is exactly connected according to manual. Plugging into head-unit does not work when the manual says to plug into monitor and vice versa.
Inserted picture totally wrong size or position.	Wrong monitor settings of video-interface.	Try different combinations of dips 7 and 8 of video-interface. Unplug 6pin power after each change.
Inserted picture double or 4 times on monitor.		
Inserted picture distorted, flickering or running vertically.	Video sources output set to AUTO or MULTI which causes a conflict with the interfaces auto detection.	Set video source output fixed to PAL or NTSC. It is best to set all video sources to the same standard.
	If error occurs only after source switching: Connected sources are not set to the same TV standard.	Set all video sources to the same standard.
	Some interfaces can only handle NTSC input.	Check manual whether there is a limitation to NTSC mentioned. If yes, set source fixed to NTSC output.
Inserted picture b/w.	Picture settings have not been adjusted.	Use the 3 buttons and the interface's OSD to adjust the picture settings for the corresponding video input.
Inserted picture qual. bad.		
Inserted picture size slightly wrong.		
Inserted picture position wrong.		
Camera input picture flickers.	Camera is being tested under fluorescent light which shines directly into the camera.	Test camera under natural light outside the garage.
Camera input picture is bluish.	Protection sticker not removed from camera lens.	Remove protection sticker from lens.

Symptom	Reason	Possible solution
Camera input picture black.	Camera power taken directly from reverse gear lamp.	Use relay or electronics to "clean" reverse gear lamp power. Alternatively, if CAN-bus box is compatible with the vehicle, camera power can be taken from green wire of 6pin to 8pin cable.
Camera input picture has distortion.		
Camera input picture settings cannot be adjusted.	Camera input picture settings can only be adjusted in AV2 mode.	Set dip 3 of video-interface to ON (if not input AV2 is not already activated) and connect the camera to AV2. Switch to AV2 and adjust settings. Reconnect camera to camera input and deactivate AV2 if not used for other source.
Graphics of a car in camera input picture.	Function PDC is ON in the interface OSD.	In compatible vehicles, the graphics will display the factory PDC distance. If not working or not wanted, set interface OSD menu item UI-CNTRL to ALLOFF.
Chinese signs in camera input picture	Function RET or ALL is ON (function for Asian market) in the interface OSD.	Set interface OSD menu item UI-CNTRL to ALLOFF or PDCON.
Not possible to switch video sources by OEM button.	CAN-bus interface does not support this function for vehicle.	Use external keypad or cut white wire of 6pin to 8pin cable and apply +12V impulses for AV-switching.
Not possible to switch video sources by external keypad.	Pressed too short.	For video source switching a longer press of about 2.5 seconds is required.
	SW-version of interface does not support external keypad.	Use OEM-button or cut white wire of 6pin to 8pin cable and apply +12V impulses for AV-switching.
Interface does not switch to camera input when reverse gear is engaged.	CAN-bus interface does not support this function for the vehicles.	Cut the green wire of the 6pin to 8pin cable and apply +12V constant from reverse gear-lamp signal. Use relay to "clean" R-gear lamp power.
Interface switches video-sources by itself.	CAN-bus interface compatibility to vehicle is limited.	Cut the grey wire of 6pin to 8pin and isolate both ends. If problem still occurs, additionally cut the white wire of 6pin to 8pin cable and isolate both ends.

6. Technical Support

Please note that direct technical support is only available for products purchased directly from NavLinkz GmbH. For products bought from other sources, contact your vendor for technical support.

NavLinkz GmbH
distribution/tech dealer-support
 Heidberghof 2
 D-47495 Rheinberg

Tel +49 2843 17595 00
 Email mail@navlinkz.de

 10R-03 5384

Made in China

